



# OFFICE OF THE PROJECT DIRECTOR

PSDP ADP SCHEME NO. 2941 OF 2024-25 / 2301 OF 2025-26

“Construction / Re-Construction of Existing Schools affected  
Under Rain / Flood 2022 in Sindh (833 Units)”

SCHOOL EDUCATION & LITERACY DEPARTMENT GOVERNMENT OF SINDH  
@ 2<sup>ND</sup> Floor, Old KDA Building, Sindh Secretariat No. 03, Karachi-Phone # 021-99211180

NO.PD/PSDP-ADP-2941/2301/NIT/2025-26/ 390 /Karachi, Dated: 14 -05-2026

To,

The Director (Advertisement),  
Information Department,  
Government of Sindh,  
Karachi.

**SUBJECT: PUBLICATION OF TENDER NOTICE.**

I am directed to enclosed please find herewith (07 Copies) of Tender Notice for publication in one insertion well reputed national dailies in English, Urdu & Sindhi due to scarcity of budget. Further it is requested that the advertisement is essential and publication be restricted to 03 Nos. newspapers only keeping in view the budgetary constraints.

It is also requested that the advertisement charges for the relevant advertisement shall be met out of the Development budget for which funds are available during the current financial year and also bill may please be sent immediately after publication of Tender Notice so as to clear the charges without accumulation as arrears.

**PROJECT DIRECTOR**  
PSDP / ADP SCHEME # 2941 OF 2024-25 /  
2301 OF 2025-26

**Copy forwarded with compliments for favour of kind information to:**

1. The Special Secretary (PDF), School Education & Literacy Department, GoS, Karachi
2. The Additional Secretary (PDF), School Education & Literacy Department, GoS, Karachi
3. The Managing Director, SPPRA, GoS, Karachi
4. The Deputy Project Director, PSDP ADP Scheme No. 2941/2024-25 & 2301/2025-26
5. The Chief Engineer, Education Works, Sukkur Region
6. The Superintending Engineer, Education Works Circle Larkana
7. The Executive Engineer, Education Works Division Kambar @ Shahdadkot
8. Chairman / Members (All), Procurement Committee
9. Copy to Office record.
10. Copy for Display on Notice Board.
11. Master File

**PROJECT DIRECTOR**  
PSDP / ADP SCHEME # 2941 OF 2024-25 /  
2301 OF 2025-26



# OFFICE OF THE PROJECT DIRECTOR

PSDP ADP SCHEME NO. 2941 OF 2024-25 / 2301 OF 2025-26

**“Construction / Re-Construction of Existing Schools  
affected under Rain / Flood 2022 in Sindh (833 Units)**

SCHOOL EDUCATION & LITERACY DEPARTMENT, GOVERNMENT OF SINDH, KARACHI  
2<sup>nd</sup> Floor, Old KDA Building, Sindh Secretariat No. 03, Karachi-Phone # 021-99211180

NO.PD-ADP-2941/2301/SE&LD/NIT/2025-26/ 390 /Karachi, Dated: 14 -05-2026

## NOTICE INVITING TENDER

Scaled tenders under Single stage-Two Envelope procedure are invited through print media & EPAD of SPPRA website from the eligible interested contractors / firms / parties having relevant experience and registered with Pakistan Engineering Council in the relevant field and appropriated category in accordance with SPPRA Rules-2010 (amended up-to-date) for the works / packages under co-sharing PSDP / ADP Scheme “Construction / Re-Construction of Existing Schools in Sindh affected under Rain / Flood 2022 (833 Units) (ADP No. 2941 of 2024-25 & 2301 of 2025-26)”.

S #	Name of School	Estimated Cost (M)	Tender Fee	Bid Security (M)	Completion Period
	<b>District Kambar- Shahdadkot</b>				
1	<b>Package 47</b> (a) GGPS-Anwarabad (SEMIS ID 427040049) (3-C/R) (b) GBPS-Gul Buriro Methion, (SEMIS ID 427040241) (3-C/R) Taluka Warrah	32.837	5,000	1.640	04 Months
2	<b>Package 49</b> (a) GBPS-Allah Rakhio Choliani (SEMIS ID 427040235) (3-C/R) (b) GBPS-Dengal Machhi (SEMIS ID 427040206) (3-C/R) Taluka Warrah	33.549	5,000	1.675	04 Months

### Eligibility Criteria (Mandatory):

1. Valid Copy of CNIC of Proprietor / Partners
2. Bid Security should be made from the Account of the Company / Firm of the participant.
3. Valid Registration with Pakistan Engineering Council (PEC) in Category C-5 or above having specialization code EE04, CE09 & CE10.
4. Valid Electrical License of Government of Sindh for Electrical Works for Larkana Region must be provided.
5. Bidder shall be an active Tax Payer List (ATL) of Federal Board of Revenue (FBR) or Sindh Revenue Board (SRB) as the case may be. Failing to which the bidder shall not be eligible to take part in bid in accordance with Rule-46 (1) (a) (iii) of SPPRA 2010 (amended till to date).

6. Proof of experience and details of similar nature of work(s) executed during last five years indicating the name of project / scheme / works with cost, date of commencement & completion in accordance with amendments in SPPRA Regulations Clause # 2.16, 7.9(i) vide Notification Dated: 10<sup>th</sup> April, 2023 (With Satisfactory Completion Certificate duly supported by documentary evidences viz: Work orders / Contract Agreements & Satisfactory Project Completion Certificates by concerned Department), the information about experiences of work(s) executed previously can also be verified from SPPRA web site:
  - a. At least one similar nature of work having minimum cost 80% of the estimated cost of work; OR
  - b. At least two similar nature works each having minimum cost 50% of the estimated cost.
7. Average Annual Financial Turn-over not less than equivalent cost of the scheme / project during last five years duly supported by the Bank Statement, Annual Tax Returns & Audit report (last 5 years each) in accordance with amendments made in SPPRA Regulations Clause # 2.16, 7.9(i) vide Notification Dated: 10<sup>th</sup> April, 2023. These must be issued by Chartered Accountant firms registered with ICAP (Institute of Chartered Accountants of Pakistan). Statement from any other firms will not be accepted.
8. Bio-data of the technical staff permanently employed with evidence and available with the firm / contractor (Attach evidence of proposed staff) (List is mentioned in bidding documents).
9. List of Equipment, Machinery, Vehicles, available with the contractor for this job with location (Details of ownership / hired) (List is mentioned in bidding documents).
10. Undertaking on Original E-Stamp Paper containing that:
  - i. The firm was not involved in any litigation, no work was rescinded in the past (List of cases entered into arbitration / litigation & list of works where penalty is involved, if any must be attached).
  - ii. The firm was not black listed (Attach all details if any). Not doing so will result in rejection of tender.
  - iii. The information / documents submitted are correct and true.

**SCHEDULE OF TENDERS SHALL BE AS FOLLOWS:**

- i. The Bidding documents containing relevant information can be accessed / downloaded from the website of SPPRA (<http://portalsindh.eprocure.gov.pk>) from the date of publication till the closing date. The tender fee (Non-Refundable) amounting to **Rs. 5,000/=** in the form of Pay Order in favor of **“Construction / Re-Construction of Existing Schools in Sindh affected under Rain / Flood 2022”** (must be attached with technical documents of E-Bid & also be uploaded to the EPAD website).
- ii. Bids will be submitted through E-PAD System before **02.06.2026 till 11:00 A.M.** along-with the Bid Security of fixed amount as mentioned against the each work in the form of Call Deposit / Pay Order / Demand Draft / Bank Guarantee issued by a scheduled Bank of Pakistan in favor of **“Construction / Re-Construction of Existing Schools in Sindh affected under Rain / Flood 2022”** (must be attached with Technical documents of E-Bid & also be uploaded to the EPAD website) (In accordance with Rule-37 (1) of SPPRA Rules-2010 (amended till to date).
- iii. Initially Technical Bids will be opened on same date at **11:30 A.M** through E-PADS bidding procedure at the Office of the Project Director, PSDP /ADP scheme # 2941/2301 situated at 2<sup>nd</sup> Floor, Old KDA Building, Sindh Secretariat # 3, Karachi in the presence of bidders or their authorized representatives who shall choose to attend the bids opening session by the procuring agency’s notified Committees as per SPP Rules, 2010 (Amended up-to-date).

- iv. The original Tender Fee, Bid Security & E-stamping Affidavits must be submitted in a sealed envelope, either by hand or through registered mail, to the Office of the Project Director, PSDP ADP Scheme, School Education & Literacy Department, Government of Sindh, Karachi @ 2<sup>nd</sup> Floor, Old KDA Building, Sindh Secretariat # 3, Karachi before the opening of the bidding process.
- v. In case of any reason, if the tenders are not responded on the above date, the next date of uploading / submitting will be up-to 18.06.2026 till 11:00 A.M. & opening of bids will be same day at 11:30 A.M.
- vi. The "Technical Proposals" shall be evaluated by the Procurement Committee to determine technical qualification in accordance with the technical evaluation criteria and mandatory requirements specified in the Bidding Documents. Thereafter "Financial Proposals" of bids that are found technically nonresponsive are disqualified shall not be opened. Conversely, the "Financial Proposals" of technically qualified bidders shall be opened publicly at a time, date and venue that will be announced and communicated to the all bidders in advance. The bid determined to be the Most Advantageous though not necessarily the lowest submitted price shall be accepted (In accordance with Rule-49 of SPPRA Rules-2010 (amended time to time)).
- vii. Bid validity period is 90 days.

**TERMS AND CONDITIONS:**

- a. Name, address, telephone, what's App numbers and e-mail address of firm / individual, ownership and organizational structure of the firm, year of establishment.
- b. In case of a representative must have authority on company letter head from his firm / company's owner including details of owners along with CNIC
- c. In case, if the date of opening or last date of submission is declared as a public holiday by the Government or the undersigned remains out of office / headquarter or non-working day due to any reason, next working day shall be deemed to be the date for last submission and opening of tenders accordingly. The time and venue shall remain the same.
- d. Only online Bids will be accepted, no physical Bid will be received.
- e. The Bid Security shall be released to the unsuccessful bidders within seven days, once the contract has been signed with the successful bidder or the validity period has expired in accordance with Rule-37 (6) of SPP Rules 2010 (amended till to date).
- f. Rate and amount must be quoted in both words & figures, tenders must be carefully & clearly filled, and each page of bid must be signed & stamped. All corrections / over writings shall be clearly re-written with initials and duly stamped by the Bidder.
- g. All clauses of Bidding Data eligibility criteria and mandatory criteria mentioned in tender / bidding documents shall have same priority, and nonfulfillment of any clause shall lead to bid rejection / disqualification.
- h. Any bid containing highly inflated or unworkable quoted rates for individual items or total premium in the Bill of Quantities (BOQ) may be deemed non-conforming and liable to rejection in accordance with Notification in respect of Clause No. Para-2 of 11.3.3 & 11.3.4 issued vide No. Dir(M&CB)/SPPRA/25-29/289, Dated: 20<sup>th</sup> October, 2025. Furthermore, the Employer reserves the right to disqualify such tenders from future bidding opportunities if they submit unworkable rates for major items of work.

- i. The firms providing unsustainable or incorrect information are liable to disqualification and legal action. Bid received without supporting documents as mentioned / required in eligibility criteria would be declared as non-responsive bid. The procurement agency reserve the right to cross verify any information provided with the bidding documents in order to keep verification or authenticity of provided information.
- j. Incomplete conditional tenders will not be accepted. The procuring agency may reject all or any bids/tenders at any time prior to the acceptance of a bid or proposal subject to the relevant provision of SPPRA Rules 2010 under Rule-25(i) (amended till to date).

**Note:**

1. *All original documents must be shown upon the request of the Procurement Committee for verification.*
2. *If any fake document is found, then the tender is liable to be rejected / cancelled without any compensation with penalty as per rules.*
3. *Canvassing in connection with tendering is strictly prohibited and proposals submitted by the contractors who are reported to be involved in canvassing are liable for rejection.*

  
PROJECT DIRECTOR

PSDP ADP SCHEME NO. 2941 OF 2024-25

& 2301 OF 2025-26

“Construction / Re-Construction of Existing Schools  
Affected under Rain / Flood-2022 in Sindh (833 Units)  
SCHOOL EDUCATION & LITERACY DEPARTMENT  
GOVERNMENT OF SINDH KARACHI



**REVISED ANNUAL PROCUREMENT PLAN FOR 2025-2026**  
**OFFICE OF THE PROJECT DIRECTOR PSDP ADP SCHEME # 2941 OF 2024-25 & 2301 OF 2025-26**  
**“Construction / Re-Construction of Existing Schools affected under Rain / Flood 2022 in Sindh (833 Units)**  
**SCHOOL EDUCATION & LITERACY DEPARTMENT GOVERNMENT OF SINDH**  
 2<sup>nd</sup> Floor, Old KDA Building, Sindh Secretariat No. 03, Karachi-Phone # 021-99211180

Sr. No.	Description of Procurement	Total Estimated Cost	Funds Allocated (Rs) in Million	Source of Funds (ADP/ Non-ADP)	Proposed Procurement Methods	Timing of Procurement				Remarks
						1 <sup>st</sup> Qtr.	2 <sup>nd</sup> Qtr.	3 <sup>rd</sup> Qtr.	4 <sup>th</sup> Qtr.	
<b>“Construction / Reconstruction of Existing Schools Affected under Rain / Flood-2022 in Sindh (833 Units) (ADP No. 2941/2024-25 &amp; 2301/2025-26)</b>										
<b>District Kambar- Shahdaddkot</b>										
1)	<b>Package 46</b> (a) GBPS-Arzi Markhand (SEMIS ID 427030007) Taluka Shahdaddkot (b) GBPS-Dilawar Jalbani (SEMIS ID 427070186) Taluka Sijawal Junejo	<b>33.696</b>	<b>33.696</b>	ADP	Single Stage Two Envelope			☞		
2)	<b>Package 47</b> (a) GGPS-Anwarabad (SEMIS ID 427040049) (b) GBPS-Gul Buriro Methion, (SEMIS ID 427040241) Taluka Warrach	<b>32.837</b>	<b>32.837</b>	ADP	Single Stage Two Envelope				☞	
3)	<b>Package 48</b> (a) GBPS-Khair Muhammad Machhi (SEMIS ID 427040003) Taluka Warrach (b) GBPS-Mir Muhammad (SEMIS ID 427060077) Taluka Naseerabad	<b>33.749</b>	<b>33.749</b>	ADP	Single Stage Two Envelope			☞		
4)	<b>Package 49</b> (a) GBPS-Allah Rakhio Choliani (SEMIS ID 427040235) Taluka Warrach (b) GBPS-Dengal Machhi (SEMIS ID 427040206) Taluka Warrach	<b>33.549</b>	<b>33.549</b>	ADP	Single Stage Two Envelope				☞	
<b>District Larkana</b>										
5)	<b>Package 50</b> (a) GBPS-Imam Bux Malah (SEMIS ID 413010099) (b) GGPS-Izzat Ji Wandh (SEMIS ID 413030024) Taluka Rato Dero	<b>33.337</b>	<b>33.337</b>	ADP	Single Stage Two Envelope				☞	
6)	<b>Package 51</b> (a) GGPS-Samtia (SEMIS ID 413010022) (b) GBPS-Rustam Bhand, (SEMIS ID 413010076), Taluka Dokri	<b>33.314</b>	<b>33.314</b>	ADP	Single Stage Two Envelope				☞	
<b>District Shaheed Benazirabad</b>										
7)	<b>Package 52</b> (a) GBPS-Isamil Chandio (SEMIS ID 417040706) (b) GBPS-Mir Rahim Bux (SEMIS ID 417040245) Taluka Daur	<b>33.431</b>	<b>33.431</b>	ADP	Single Stage Two Envelope				☞	
8)	<b>Package 53</b> (a) GBPS-Muhammad Haroon Mashori (SEMIS ID 417040252) Taluka Daur (b) GBPS-Ghanwar Khan Chandio (SEMIS ID 417040285) Taluka Daur	<b>33.186</b>	<b>33.186</b>	ADP	Single Stage Two Envelope				☞	
9)	<b>Package 54</b> (a) GBPS-Dinal Shah (SEMIS ID 417040170), Taluka Daur (b) GBPS-Dil Murad Brohi, (SEMIS ID 417030006), Taluka Daur	<b>32.866</b>	<b>32.866</b>	ADP	Single Stage Two Envelope				☞	





GOVERNMENT OF SINDH  
SCHOOL EDUCATION & LITERACY DEPARTMENT

Karachi dated: 19/01/2026

**NOTIFICATION**

No.SO(P)/SELD/CRC-PSDP/2024: In Supersession of this Department's Notification of even number dated 04<sup>th</sup> October 2024, the Procurement Committee (PC) is reconstituted for Works, Goods & Services with following composition & TORs in respect of PSDP Scheme "Construction/ Reconstruction of existing schools in Sindh affected under Rain/ Flood 2022 in Sindh (833 Units)" under the Administrative Control of PDR, School Education & Literacy Department:-

- |   |                   |
|---|-------------------|
| 1. The Project Director, PSDP,<br>School Education & Literacy Department    | Chairman          |
| 2. Deputy Project Director, PSDP.<br>School Education & Literacy Department | Member/ Secretary |
| 3. Executive Engineer, Education Works,<br>College Education Department     | Member            |

**TORs:**

- To prepare Bidding Documents.
- To carryout Technical as well as Financial Evaluation of Bids
- To prepare Evaluation Reports as provided in Rule 45 of SPPRA Rules 2010.
- To finalize and recommend to award the contract to the successful bidders and
- Perform any other function ancillary and incidental to the above.

**-ZAHID ALI ABBASI-  
SECRETARY TO GOVT. OF SINDH**

No.SO(P)/SELD/PDR/PC-PSDP/2024

Karachi, dated the 19/01/2026

A copy is forwarded for information & necessary action to: -

1. The Managing Director, SPPRA.
2. P.S to Minister for Education & Literacy Department.
3. P.S to Secretary, School Education & Literacy Department.
4. P.S to Secretary, College Education Department for nomination of the Officer.
5. P.S to Special Secretary (PDF), School Education & Literacy Department.
6. P.A to Additional Secretary (PDF), School Education & Literacy Department.
7. P.A to Director General, PDR/ Project Director, PSDP.
8. All Members of the Committee.
9. Official Web



**SECTION OFFICER (PLANNING)**



**GOVERNMENT OF SINDH  
SCHOOL EDUCATION & LITERACY DEPARTMENT.**

Karachi dated the 17th 2025

**NOTIFICATION**

**NO:SO(P)/SELD/CRC-PSDP/2024:** In Supersession of this Department's Notification of even number dated 04<sup>th</sup> October 2024, a Department Complaint Redressal Committee (CRC) comprising of following Officers is reconstituted to resolve the Complaints of aggrieved bidders (if any) in respect of the PSDP Scheme "Construction/ Re-construction of existing Schools in Sindh affected under Rain / Flood 2022 in Sindh (833 Units) ADP-2941 of 2024-25" under the Administrative Control of PDR, School Education & Literacy Department:-

1. Special Secretary (PDF) (BS-20), School Education & Literacy Chairman Department.
2. Chief Engineer, (BS-20), Education Works, Karachi Region, School Member Education & Literacy Department.
3. Deputy Director PDR / Deputy Project Coordinator, PSDP (BS-18), Member/Secretary School Education & Literacy Department.
4. Independent Professional from the relevant field concerning nominated Member by the Head of Procuring Agency.
5. Representative of Accountant General Sindh, Karachi. Member

TORs: -

- To perform according to Rule-31 of SPPRA Rules, 2010:
- Perform any other function ancillary and incidental to the above.

**-ZAHID ALI ABBASI-  
SECRETARY TO GOVT. OF SINDH**

**NO:SO(P)/SELD/CRC-PSDP/2024:**

Karachi dated the 17th April, 2025

A copy is forwarded for information and necessary action to:

- The Accountant General Sindh, Karachi.
- The Managing Director, SPPRA.
- P.S to Minister for Education & Literacy Department.
- P.S. to Secretary, School Education & Literacy Department.
- P.A to Additional Secretary, (PD&F) School Education & Literacy Department.
- P.A. to Director General, PDR/ Project Director, ADP # 2941 Federal PSDP Scheme, School Education & Literacy Department.
- All Members of the Committee.
- The official website.



SCHOOL EDUCATION &  
LITERACY DEPARTMENT



SECTION OFFICER (PLANNING)

*17-04-2025*

**OFFICE OF THE PROJECT DIRECTOR**  
**PSDP ADP SCHEME # 2941 OF 2024-25 AND 2301 OF 2025-26**  
**“Construction / Re-Construction of Existing Schools in Sindh**  
**Affected under Rain / Flood 2022 in Sindh (833 Units)”**  
**SCHOOL EDUCATION & LITERACY DEPARTMENT**  
**GOVERNMENT OF SINDH KARACHI**



**SINDH PUBLIC PROCUREMENT REGULATORY AUTHORITY (SPPRA)**  
**STANDARD FORM OF BIDDING DOCUMENT (VOLUME-I)**

**NIT NO.PD/ADP-2941/PDR/SE&LD/NIT/2025-26/390/Karachi, Dated: 14.05.2026**

**Name of Work: Construction / Re-Construction of Existing Schools in Sindh affected under Rain / Flood 2022 in Sindh (833 Units) (ADP No. 2941 of 2024-25 & 2301 of 2025-26) Package No. 49 – District Kambar-Shahdadkot (02 Units) (Construction of 3-Classroomed Primary School)**

SEMIS ID	SCHOOL NAME	TALUKA	DISTRICT
427040235	GBPS-Allah Rakhio Choliani	Warrah	Kambar-Shahdadkot
427040206	GBPS-Dengal Machhi	Warrah	Kambar-Shahdadkot

Estimated Cost: Rs. 33.549 Million

Bid Security: Rs. 1.675 Million

Tender Cost: Rs. 5,000/-

Downloaded by M/s. \_\_\_\_\_

P. O. No. \_\_\_\_\_, Dated: \_\_\_\_\_

Bank & Branch: \_\_\_\_\_

Signature and Stamp of Procuring Agency

## **INSTRUCTIONS TO PROCURING AGENCIES**

### **(Not to be included in Bidding Documents)**

#### **A. Basis of Documents**

These Documents have been prepared as a global document intended to be used by different agencies/users according to their requirements. This document is envisaged for National Competitive Bidding (NCB), meant for use for Works costing not more than Rs. 25 Million. These documents may be tailored according to the scope of works as well as in case of contracts on International Competitive Bidding (ICB) basis, funded by international financial institutions/donors, with payments in foreign currencies. Procuring agencies are then to tailor the relevant clauses to suit their requirements including appropriate modifications in the relevant sections of the documents in the light of SPPRA Bidding Documents for Large Works.

The Procuring Agency is expected to manage the Contract itself. The role of Engineer may be added by the Procuring Agency, if the Procuring Agency wishes to engage a consultant. The role of the Engineer with specific delegated powers under various clauses of Instructions to Bidders such as clarifications of Bid Documents, Amendment of Bid Documents, and evaluation of Bids etc. and to administer the Contract under various clauses of Conditions of Contract should have been specified. The Procuring Agency will be required to set out in the specifications and drawings the full scope of work including the extent of design to be done by the Contractor, if any.

#### **B. Contents of Documents**

As stated in Clause IB.4 of Instructions to Bidders, the complete Bidding Documents in addition to Invitation for Bids shall comprise items listed therein including any addendum to Bidding Documents issued in accordance with IB.6. The Standard Form of Bidding Documents (for Small Contracts) includes the following:

1. Instructions to Bidders & Bidding Data
2. Form of Bid & Schedules to Bid
3. Conditions of Contract & Contract Data
4. Standard Forms
5. Specifications
6. Drawings, if any

In addition, Instructions to procuring agencies are also provided at various locations of this document within parenthesis or as a Note(s). Procuring agencies are expected to edit or finalise this document accordingly, by filling in all the relevant blank spaces and forms as per the scope of the work, deleting all notes and instructions intended to help the bidders. The procuring agency is required to prepare the following for completion of the Bidding Documents:

(i) Invitation for Bids

Sindh Public Procurement Regulatory Authority | [www.pprasindh.gov.pk](http://www.pprasindh.gov.pk)

(ii) Bidding Data

(iii) Schedules to Bid (Samples)

(iv) Schedule of Prices (Format)

(v) Contract Data

(vi) Specifications

(vii) Drawings, if any

The Procuring agency's attention is drawn to the following while finalizing the Bidding Documents.

#### **C. Notice Inviting Tender/ Invitation for Bids/ Request for Expression of Interest**

The —Notice Inviting Tender is meant for publication of tenders for calling bids in the newspapers and SPPRA Website. The blank spaces wherever shown are required to be filled by the Procuring Agency before

issuance of Bidding Documents. The Procuring Agency may modify para 1 of Notice Inviting Tender as per its requirements. The notice should be published so as to give the interested bidders sufficient working period

for preparation and submission of bids – not less than 15 days for National Competitive Bidding and 45 days for International Competitive Bidding (SPP Rule 18).

1. The eligible bidders are defined in IB.2; the text can be amended by the Procuring Agency as deemed appropriate.
2. The non-refundable fee for the sale of Bidding Documents should be nominal so as to cover printing/reproduction and mailing costs and to ensure that only bona-fide bidders shall apply (SPP Rule 20).
3. The amount of Bid Security should be a lump sum figure or a percentage, but not less than 1% and more than 5% of bid price and should be in accordance with IB.13.1 (SPP Rule 37).
4. If the venue of receipt of bids and the opening of bids is the same, the times for receipt and opening of bids are to be entered in last Para of the Notice Inviting Tender, otherwise indicate the name, address and exact location for the opening of bids. However the date for the receipt and the opening of bids shall be same (SPP Rule 41).

#### **D. Instructions to Bidders**

These Instructions to Bidders will not be part of Contract and will cease to have effect once the Contract is signed along with Bidding Data. The Instructions to Bidders can be used as given. Procuring agency may have to make changes under Bidding Data. The Procuring Agency's or Engineer's Representative, if any, shall exercise powers of the Engineer/Procuring Agency under and in connection with Clauses IB.5, IB.6, IB.16, etc. In Sindh Public Procurement Regulatory Authority | [www.pprasindh.gov.pk](http://www.pprasindh.gov.pk) case an Engineer has been appointed by the Procuring Agency, the aforesaid clauses may be modified accordingly to specify the role of the Engineer by the Procuring Agency, otherwise the Engineer's reference wherever exist, except Sub-Clause 1.1.20 & Clause 15 of Conditions of Contract and Item 1.1.20 of Contract Data, shall be deleted.

#### **E. Bidding Data**

The blank spaces wherever shown in Bidding Data are required to be filled by the Engineer/Procuring Agency before issuance of Bidding Documents.

1. Contents of IB.10.3 may be retained or modified by the Procuring Agency.
2. Procuring Agency should insert required experience in IB.11.2.
3. Referring to IB.14.1, the period of bid validity may range from 30 to 90 days depending upon the size and nature of the works. Number of days shall be filled in as per Procuring Agency's requirements.
4. Contents of IB.16.3 to IB.16.8 may be retained or modified by the Procuring Agency in accordance with its requirements.

#### **F. Schedules to Bid**

Specimen of Schedules to Bid including format of Schedule of Prices are provided in this document. The Procuring Agency may add/delete/modify as per its requirement. The blank spaces wherever shown are required to be filled by the Engineer/Procuring Agency before issuance of Bidding Documents except those required to be provided by the Contractor.

#### **G. Conditions of Contract**

The procuring agency while preparing Contract Data, shall ensure that no Clause of Conditions of Contract is deleted and that the changes included in Contract Data shall be such as not to change the spirit of the document. Any adjustment or change in clauses of Conditions of Contract to meet specific project features shall be made with care and incorporated in Contract Data.

#### **H. Contract Data**

The blank spaces wherever shown are required to be filled by the Engineer/Procuring Agency before issuance of Bidding Documents.

1. Referring to Sub-Clause 1.1.1 of Conditions of Contract, the Engineer/Procuring Agency may add, in order of priority, such other documents as to form part of the Contract, in Sub-Clause 1.3 of the Contract Data.
2. The Procuring Agency's Representative, if any, shall exercise powers of the Procuring Agency under and in connection with Sub-Clauses 1.3, 2.3, 4.2, 4.3, 5.1, 7.3, 8.2, 9.1, 9.2, 10.1, 10.2, 10.5, 11.1, 11.5, 12.1,

13.2 and 14.1 of the Conditions of Contract. In case an Engineer has been appointed by the Procuring Agency, the aforesaid clauses may be modified accordingly by the Procuring Agency.

Sindh Public Procurement Regulatory Authority | [www.pprasindh.gov.pk](http://www.pprasindh.gov.pk)

3. The sum insured for different insurances including minimum amount of third party insurance should be assessed by the Engineer/Procuring Agency and entered in Contract Data. Such insurance cover shall be carried out with Insurance Company having at least AA rating from PACRA / JCR in the favour of the procuring agency.

4. The time for completion of the whole of the works should be assessed by the Engineer/Procuring Agency and entered in the Contract Data.

5. The Conditions of Contract contain no overall limit on the Contractor's liability. The amount of **liquidated damages** per day of delay shall be entered by the Engineer/Procuring Agency in Contract Data. Usually the liquidated damages are set between **0.05 percent and 0.10 percent per day and the maximum limit as 10**

**percent of contract price stated in the Letter of Acceptance.**

6. Any amendment and/or additions to the Conditions of the Contract that are specific to a given Bid/Contract should be included by the Procuring agency. This may include but not be limited to the provisions regarding the following:

a) Terms of Payment should be prepared and incorporated in Contract Data by the Engineer/Procuring Agency.

b) The Engineer/Procuring Agency to make sure that all taxes and duties are included by the Bidders/Contractors in their prices.

### **I. Specifications**

To be prepared and incorporated by the Engineer/Procuring Agency

### **J. Drawings**

To be prepared and incorporated by the Engineer/Procuring Agency, if required.

## SUMMARY OF CONTENTS

### Subject

(I)	INVITATION FOR BIDS.....
(II)	INSTRUCTIONS TO BIDDERS.....
(III)	BIDDING DATA .....
(IV)	FORM OF BID & SCHEDULES TO BID .....
(V)	CONDITIONS OF CONTRACT & CONTRACT DATA .....
(VI)	CONTACT FORMS .....
(VII)	SPECIFICATIONS .....
(VIII)	DRAWINGS .....

# **INVITATION FOR BIDS**



## OFFICE OF THE PROJECT DIRECTOR

PSDP ADP SCHEME NO. 2941 OF 2024-25 / 2301 OF 2025-26

"Construction / Re-Construction of Existing Schools affected  
Under Rain / Flood 2022 in Sindh (833 Units)"

SCHOOL EDUCATION & LITERACY DEPARTMENT GOVERNMENT OF SINDH  
@ 2<sup>ND</sup> Floor, Old KDA Building, Sindh Secretariat No. 03, Karachi-Phone # 021-99211180

NO.PD/PSDP-ADP-2941/2301/NIT/2025-26/ 390 /Karachi, Dated: 14/ -05-2026

To,

The Director (Advertisement),  
Information Department,  
Government of Sindh,  
Karachi.

**SUBJECT: PUBLICATION OF TENDER NOTICE.**

I am directed to enclosed please find herewith (07 Copies) of Tender Notice for publication in one insertion well reputed national dailies in English, Urdu & Sindhi due to scarcity of budget. Further it is requested that the advertisement is essential and publication be restricted to 03 Nos. newspapers only keeping in view the budgetary constraints.

It is also requested that the advertisement charges for the relevant advertisement shall be met out of the Development budget for which funds are available during the current financial year and also bill may please be sent immediately after publication of Tender Notice so as to clear the charges without accumulation as arrears.

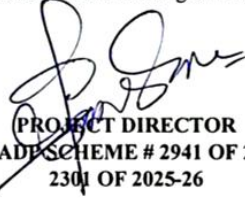
  
PROJECT DIRECTOR  
PSDP / ADP SCHEME # 2941 OF 2024-25 /  
2301 OF 2025-26

**Copy forwarded with compliments for favour of kind information to:**

1. The Special Secretary (PDF), School Education & Literacy Department, GoS, Karachi
2. The Additional Secretary (PDF), School Education & Literacy Department, GoS, Karachi
3. The Managing Director, SPPRA, GoS, Karachi
4. The Deputy Project Director, PSDP ADP Scheme No. 2941/2024-25 & 2301/2025-26
5. The Chief Engineer, Education Works, Sukkur Region
6. The Superintending Engineer, Education Works Circle Larkana
7. The Executive Engineer, Education Works Division Kambar @ Shahdadkot
8. Chairman / Members (All), Procurement Committee
9. Copy to Office record.
10. Copy for Display on Notice Board.
11. Master File

PROJECT DIRECTOR  
PSDP / ADP SCHEME # 2941 OF 2024-25 /  
2301 OF 2025-26



## OFFICE OF THE PROJECT DIRECTOR

PSDP ADP SCHEME NO. 2941 OF 2024-25 / 2301 OF 2025-26

“Construction / Re-Construction of Existing Schools

affected under Rain / Flood 2022 in Sindh (833 Units)

SCHOOL EDUCATION & LITERACY DEPARTMENT, GOVERNMENT OF SINDH, KARACHI

2<sup>nd</sup> Floor, Old KDA Building, Sindh Secretariat No. 03, Karachi-Phone # 021-99211180

NO.PD-ADP-2941/2301/SE&LD/NIT/2025-26/ 390 /Karachi, Dated: 14-05-2026

### NOTICE INVITING TENDER

Sealed tenders under Single stage-Two Envelope procedure are invited through print media & EPAD of SPPRA website from the eligible interested contractors / firms / parties having relevant experience and registered with Pakistan Engineering Council in the relevant field and appropriated category in accordance with SPPRA Rules-2010 (amended up-to-date) for the works / packages under co-sharing PSDP / ADP Scheme “Construction / Re-Construction of Existing Schools in Sindh affected under Rain / Flood 2022 (833 Units) (ADP No. 2941 of 2024-25 & 2301 of 2025-26)”.

S #	Name of School	Estimated Cost (M)	Tender Fee	Bid Security (M)	Completion Period
	<b>District Kambar- Shahdadkot</b>				
1	<b>Package 47</b> (a) GGPS-Anwarabad (SEMIS ID 427040049) (3-C/R) (b) GBPS-Gul Buriro Methion, (SEMIS ID 427040241) (3-C/R) Taluka Warrah	32.837	5,000	1.640	04 Months
2	<b>Package 49</b> (a) GBPS-Allah Rakhio Choliani (SEMIS ID 427040235) (3-C/R) (b) GBPS-Dengal Machhi (SEMIS ID 427040206) (3-C/R) Taluka Warrah	33.549	5,000	1.675	04 Months

#### Eligibility Criteria (Mandatory):

1. Valid Copy of CNIC of Proprietor / Partners
2. Bid Security should be made from the Account of the Company / Firm of the participant.
3. Valid Registration with Pakistan Engineering Council (PEC) in Category C-5 or above having specialization code EE04, CE09 & CE10.
4. Valid Electrical License of Government of Sindh for Electrical Works for Larkana Region must be provided.
5. Bidder shall be an active Tax Payer List (ATL) of Federal Board of Revenue (FBR) or Sindh Revenue Board (SRB) as the case may be. Failing to which the bidder shall not be eligible to take part in bid in accordance with Rule-46 (1) (a) (iii) of SPPRA 2010 (amended till to date).

- 
6. Proof of experience and details of similar nature of work(s) executed during last five years indicating the name of project / scheme / works with cost, date of commencement & completion in accordance with amendments in SPPRA Regulations Clause # 2.16, 7.9(i) vide Notification Dated: 10<sup>th</sup> April, 2023 (With Satisfactory Completion Certificate duly supported by documentary evidences viz: Work orders / Contract Agreements & Satisfactory Project Completion Certificates by concerned Department), the information about experiences of work(s) executed previously can also be verified from SPPRA web site:
    - a. At least one similar nature of work having minimum cost 80% of the estimated cost of work; OR
    - b. At least two similar nature works each having minimum cost 50% of the estimated cost.
  7. Average Annual Financial Turn-over not less than equivalent cost of the scheme / project during last five years duly supported by the Bank Statement, Annual Tax Returns & Audit report (last 5 years each) in accordance with amendments made in SPPRA Regulations Clause # 2.16, 7.9(i) vide Notification Dated: 10<sup>th</sup> April, 2023. These must be issued by Chartered Accountant firms registered with ICAP (Institute of Chartered Accountants of Pakistan). Statement from any other firms will not be accepted.
  8. Bio-data of the technical staff permanently employed with evidence and available with the firm / contractor (Attach evidence of proposed staff) (List is mentioned in bidding documents).
  9. List of Equipment, Machinery, Vehicles, available with the contractor for this job with location (Details of ownership / hired) (List is mentioned in bidding documents).
  10. Undertaking on Original E-Stamp Paper containing that:
    - i. The firm was not involved in any litigation, no work was rescinded in the past (List of cases entered into arbitration / litigation & list of works where penalty is involved, if any must be attached).
    - ii. The firm was not black listed (Attach all details if any). Not doing so will result in rejection of tender.
    - iii. The information / documents submitted are correct and true.

**SCHEDULE OF TENDERS SHALL BE AS FOLLOWS:**

- i. The Bidding documents containing relevant information can be accessed / downloaded from the website of SPPRA (<http://portalsindh.eprocure.gov.pk>) from the date of publication till the closing date. The tender fee (Non-Refundable) amounting to **Rs. 5,000/=** in the form of Pay Order in favor of **“Construction / Re-Construction of Existing Schools in Sindh affected under Rain / Flood 2022”** (must be attached with technical documents of E-Bid & also be uploaded to the EPAD website).
- ii. Bids will be submitted through E-PAD System before **02.06.2026 till 11:00 A.M.** along-with the Bid Security of fixed amount as mentioned against the each work in the form of Call Deposit / Pay Order / Demand Draft / Bank Guarantee issued by a scheduled Bank of Pakistan in favor of **“Construction / Re-Construction of Existing Schools in Sindh affected under Rain / Flood 2022”** (must be attached with Technical documents of E-Bid & also be uploaded to the EPAD website) (In accordance with Rule-37 (1) of SPPRA Rules-2010 (amended till to date).
- iii. Initially Technical Bids will be opened on same date at **11:30 A.M** through E-PADS bidding procedure at the Office of the Project Director, PSDP /ADP scheme # 2941/2301 situated at 2<sup>nd</sup> Floor, Old KDA Building, Sindh Secretariat # 3, Karachi in the presence of bidders or their authorized representatives who shall choose to attend the bids opening session by the procuring agency’s notified Committees as per SPP Rules, 2010 (Amended up-to-date).

- iv. The original Tender Fee, Bid Security & E-stamping Affidavits must be submitted in a sealed envelope, either by hand or through registered mail, to the Office of the Project Director, PSDP ADP Scheme, School Education & Literacy Department, Government of Sindh, Karachi @ 2<sup>nd</sup> Floor, Old KDA Building, Sindh Secretariat # 3, Karachi before the opening of the bidding process.
- v. In case of any reason, if the tenders are not responded on the above date, the next date of uploading / submitting will be up-to 18.06.2026 till 11:00 A.M. & opening of bids will be same day at 11:30 A.M.
- vi. The "Technical Proposals" shall be evaluated by the Procurement Committee to determine technical qualification in accordance with the technical evaluation criteria and mandatory requirements specified in the Bidding Documents. Thereafter "Financial Proposals" of bids that are found technically nonresponsive are disqualified shall not be opened. Conversely, the "Financial Proposals" of technically qualified bidders shall be opened publicly at a time, date and venue that will be announced and communicated to the all bidders in advance. The bid determined to be the Most Advantageous though not necessarily the lowest submitted price shall be accepted (In accordance with Rule-49 of SPPRA Rules-2010 (amended time to time)).
- vii. Bid validity period is 90 days.

**TERMS AND CONDITIONS:**

- a. Name, address, telephone, what's App numbers and e-mail address of firm / individual, ownership and organizational structure of the firm, year of establishment.
- b. In case of a representative must have authority on company letter head from his firm / company's owner including details of owners along with CNIC
- c. In case, if the date of opening or last date of submission is declared as a public holiday by the Government or the undersigned remains out of office / headquarter or non-working day due to any reason, next working day shall be deemed to be the date for last submission and opening of tenders accordingly. The time and venue shall remain the same.
- d. Only online Bids will be accepted, no physical Bid will be received.
- e. The Bid Security shall be released to the unsuccessful bidders within seven days, once the contract has been signed with the successful bidder or the validity period has expired in accordance with Rule-37 (6) of SPP Rules 2010 (amended till to date).
- f. Rate and amount must be quoted in both words & figures, tenders must be carefully & clearly filled, and each page of bid must be signed & stamped. All corrections / over writings shall be clearly re-written with initials and duly stamped by the Bidder.
- g. All clauses of Bidding Data eligibility criteria and mandatory criteria mentioned in tender / bidding documents shall have same priority, and nonfulfillment of any clause shall lead to bid rejection / disqualification.
- h. Any bid containing highly inflated or unworkable quoted rates for individual items or total premium in the Bill of Quantities (BOQ) may be deemed non-conforming and liable to rejection in accordance with Notification in respect of Clause No. Para-2 of 11.3.3 & 11.3.4 issued vide No. Dir(M&CB)/SPPRA/25-29/289, Dated: 20<sup>th</sup> October, 2025. Furthermore, the Employer reserves the right to disqualify such tenders from future bidding opportunities if they submit unworkable rates for major items of work.

- i. The firms providing unsustainable or incorrect information are liable to disqualification and legal action. Bid received without supporting documents as mentioned / required in eligibility criteria would be declared as non-responsive bid. The procurement agency reserve the right to cross verify any information provided with the bidding documents in order to keep verification or authenticity of provided information.
- j. Incomplete conditional tenders will not be accepted. The procuring agency may reject all or any bids/tenders at any time prior to the acceptance of a bid or proposal subject to the relevant provision of SPPRA Rules 2010 under Rule-25(i) (amended till to date).

**Note:**

1. *All original documents must be shown upon the request of the Procurement Committee for verification.*
2. *If any fake document is found, then the tender is liable to be rejected / cancelled without any compensation with penalty as per rules.*
3. *Canvassing in connection with tendering is strictly prohibited and proposals submitted by the contractors who are reported to be involved in canvassing are liable for rejection.*

  
PROJECT DIRECTOR  
PSDP ADP SCHEME NO. 2941 OF 2024-25  
& 2301 OF 2025-26  
"Construction / Re-Construction of Existing Schools  
Affected under Rain / Flood-2022 in Sindh (833 Units)  
SCHOOL EDUCATION & LITERACY DEPARTMENT  
GOVERNMENT OF SINDH KARACHI

**INSTRUCTIONS TO  
BIDDERS**

## TABLE OF CONTENTS

### INSTRUCTIONS TO BIDDERS

<b>Clause No.</b>	<b>Description</b>	<b>Page No.</b>
<b>A. GENERAL</b>		
IB.1	Scope of Bid & Source of Funds .....	6
IB.2	Eligible Bidders .....	6
IB.3	Cost of Bidding .....	7
<b>B. BIDDING DOCUMENTS</b>		
IB.4	Contents of Bidding Documents .....	7
IB.5	Clarification of Bidding Documents .....	7
IB.6	Amendment of Bidding Documents .....	8
<b>C- PREPARATION OF BID</b>		
IB.7	Language of Bid .....	8
IB.8	Documents Comprising the Bid .....	8
IB.9	Sufficiency of Bid.....	8
IB.10	Bid Prices, Currency of Bid & Payment.....	9
IB.11	Documents Establishing Bidder 's Eligibility and Qualifications ..	9
IB.12	Documents Establishing Works Conformity to Bidding Documents .....	9
IB.13	Bidding Security .....	10
IB.14	Validity of Bids, Format, Signing and Submission of Bid .....	10
<b>D-SUBMISSION OF BID</b>		
IB.15	Deadline for Submission, Modification & Withdrawal of Bids .....	11
<b>E. BID OPENING AND EVALUATION</b>		
IB.16	Bid Opening, Clarification and Evaluation .....	12
IB.17	Process to be Confidential .....	13
<b>F. AWARD OF CONTRACT</b>		
IB.18	Qualification .....	13
IB.19	Award Criteria & Procuring Agency 's Right .....	14
IB.20	Notification of Award & Signing of Contract Agreement .....	14
IB.21	Performance Security .....	14
IB.22	Integrity Pact .....	15

## INSTRUCTIONS TO BIDDERS

(Note: *These Instructions to Bidders (IB) along with Bidding Data will not be part of Contract and will cease to have effect once the Contract is signed.*)

### A. GENERAL

#### IB.1 Scope of Bid & Source of Funds

##### 1.1 Scope of Bid

The Procuring Agency as defined in the Bidding Data (hereinafter called –the Procuring Agency) wishes to receive Bids for the Works summarized in the Bidding Data (hereinafter referred to as –the Works).

Bidders must quote for the complete scope of work. Any Bid covering partial scope of work will be rejected as non-responsive.

##### 1.2 Source of Funds

The Procuring Agency has arranged funds from the Co-Sharing PSDP ADP # 2941 of 2024-2025 & 2301 of 2025-2026, which may be indicated accordingly in bidding data towards the cost of the project/scheme.

#### IB.2 Eligible Bidders

2.1 Technical Bidding is open to all firms and persons meeting the following requirements:

1. Valid Copy of CNIC of Proprietor / Partners
2. Bid Security / Earnest Money should be made from the Account of the Company / Firm of the participant.
3. Bid should be signed along-with company's stamp on each page of financial & technical documents.
4. Valid Registration with Pakistan Engineering Council (PEC) in Category C-5 and having specialization code EE04, CE09 & CE10.
5. Valid Electrical License of Government of Sindh for Electrical Works for concern Region must be provided.
6. Bidder shall be an active Tax Payer List (ATL) of Federal Board of Revenue (FBR) or Sindh Revenue Board (SRB) as the case may be, failing to which the bidder shall not be eligible to take part in bid in accordance with Rule-46 sub rule (1) clause (a) sub clause of SPP Rules-2010 (amended till to date).

7. Proof of experience and details of similar nature of work(s) executed during the last five years indicating the name of project / scheme / works with cost, date of commencement & completion in accordance with amendments in SPPRA Regulations Clause # 2.16, 7.9(i) vide Notification Dated: 10<sup>th</sup> April, 2023 (With Satisfactory Completion Certificate duly supported by documentary evidences viz: Work orders / Contract Agreements & Satisfactory Project Completion Certificates by concerned Department), the information about experiences of work(s) executed previously can also be verified from SPPRA web site:
  - a. At least one similar nature of work having minimum cost 80% of the estimated cost of work; OR
  - b. At least two similar nature works each having minimum cost 50% of the estimated cost.
8. Average Annual Financial Turn-over not less than equivalent cost of the scheme / project during last five years duly supported by the Bank Statement, Annual Tax Returns & Audit report (last 5 years each) in accordance with amendments made in SPPRA Regulations Clause # 2.16, 7.9(i) vide Notification Dated: 10<sup>th</sup> April, 2023. These must be issued by Chartered Accountant firms registered with ICAP (Institute of Chartered Accountants of Pakistan). Statement from any other firms will not be accepted.
9. Bio-data of the technical staff permanently employed with evidence and available with the firm / contractor (Attach evidence of proposed staff) (List is mentioned in bidding documents).
10. List of Equipment, Machinery, Vehicles, available with the contractor for this job with location (Details of ownership / hired) (List is mentioned in bidding documents).
11. Undertaking on Original E-Stamp Paper containing that:
  - i. The firm was not involved in any litigation, no work was rescinded in the past (List of cases entered into arbitration / litigation & list of works where penalty is involved, if any must be attached).
  - ii. The firm was not black listing (Attach all details if any). Not doing so will result in rejection of tender.
  - iii. The information / documents submitted are correct and true.

### **IB.3 Cost of Bidding**

- 3.1 The bidder shall bear all costs associated with the preparation and submission of its bid and the Procuring Agency will in no case be responsible or liable for those costs, regardless of the conduct or outcome of the bidding process (SPP Rules 24 & 25).

## **B. BIDDING DOCUMENTS**

### **IB.4 Contents of Bidding Documents**

4.1 In addition to Invitation for Bids, the Bidding Documents are those stated below, and should be read in conjunction with any Addendum issued in accordance with Sub-Clause IB.6.1.

1. Instructions to Bidders & Bidding Data
2. Form of Bid, Qualification Information & Schedules to Bid  
Schedules to Bid comprise the following:
  - (i) Schedule A: Schedule of Prices/ Bill of Quantities (BoQ).
  - (ii) Schedule B: Specific Works Data
  - (iii) Schedule C: Works to be Performed by Subcontractors
  - (iv) Schedule D: Proposed Programme of Works
  - (v) Schedule E: Method of Performing Works
  - (vi) Schedule F: Integrity Pact (works costing Rs 10 million and above)
3. Conditions of Contract & Contract Data
4. Standard Forms:
  - (i) Form of Bid Security,
  - (ii) Form of Performance Security;
  - (iii) Form of Contract Agreement;
  - (iv) Form of Bank Guarantee for Advance Payment.
5. Specifications
6. Drawings, if any

### **IB.5 Clarification of Bidding Documents**

5.1 A prospective bidder requiring any clarification(s) in respect of the Bidding Documents may notify the Engineer/Procuring Agency at the Engineer 's/ Procuring Agency 's address indicated in the Bidding Data.

5.2 An interested bidder, who has obtained bidding documents, may request for clarification of contents of bidding documents in writing and procuring agency shall respond to such queries in writing within three calendar days, provided they are received at least five calendar days prior to the date of opening of bid (SPP Rule 23-1).

### **IB.6 Amendment of Bidding Documents (SPP Rules 22(2) & 22).**

6.1 At any time prior to the deadline for submission of Bids, the Procuring Agency may, for any reason, whether at his own initiative or in response to a clarification requested by an interested bidder, modify the Bidding Documents by issuing addendum.

- 6.2 Any addendum thus issued shall be part of the Bidding Documents pursuant to Sub- Clause 6.1 hereof, and shall be communicated in writing to all purchasers of the Bidding Documents. Prospective bidders shall acknowledge receipt of each addendum in writing to the Procuring Agency.
- 6.3 To afford interested bidders reasonable time in which to take an addendum into account in preparing their Bids, the Procuring Agency may at its discretion extend the deadline for submission of Bids.

## **C. PREPARATION OF BIDS**

### **IB.7 Language of Bid**

- 7.1 All documents relating to the Bid shall be in the language specified in the Contract Data.

### **IB.8 Documents Comprising the Bid**

- 8.1 The Bid submitted by the bidder shall comprise the following:
- (a) Offer /Covering Letter
  - (b) Form of Bid duly filled, signed and sealed, in accordance with IB.14.3.
  - (c) Schedules (A to F) to Bid duly filled and initialed, in accordance with the instructions contained therein & in accordance with IB.14.3.
  - (d) Bid Security furnished in accordance with IB.13.
  - (e) Power of Attorney in accordance with IB 14.5.
  - (f) Documentary evidence in accordance with IB.2(c) & IB.11
  - (g) Documentary evidence in accordance with IB.12.

### **IB.9 Sufficiency of Bid**

- 9.1 Each bidder shall satisfy himself before Bidding as to the correctness and sufficiency of his Bid and of the premium on the rates of CSR / rates and prices quoted/entered in the Schedule of Prices, which rates and prices shall except in so far as it is otherwise expressly provided in the Contract, cover all his obligations under the Contract and all matters and things necessary for the proper completion of the works.
- 9.2 The bidder is advised to obtain for himself at his own cost and responsibility all information that may be necessary for preparing the bid and entering into a Contract for execution of the Works.

### **IB.10 Bid Prices, Currency of Bid and Payment**

- 10.1 The bidder shall fill up the Schedule of Prices (Schedule A to Bid) indicating the percentage above or below the Composite Schedule of Rates/unit rates and prices of the Works to be performed under the Contract. Prices in the Schedule of Prices/Bill of Quantities shall be quoted entirely in Pak Rupees keeping in view the instructions contained in the Preamble to Schedule of Prices.
- 10.2 Unless otherwise stipulated in the Conditions of Contract, prices quoted by the bidder shall

remain fixed during the bidder 's performance of the Contract and not subject to variation on any account.

- 10.3 The unit rates and prices in the Schedule of Prices or percentage above or below on the composite schedule of rates shall be quoted by the bidder in the currency as stipulated in Bidding Data.
- 10.4 Items for which no rate or price is entered by the Bidder will not be paid for by the Procuring Agency when executed and shall be deemed covered by the other rates and prices in the Bill of Quantities.

### **IB.11 Documents Establishing Bidder's Eligibility and Qualifications**

- 11.1 Pursuant to Clause IB.8, the bidder shall furnish, as part of its bid, documents establishing the bidder 's eligibility to bid and its qualifications to perform the Contract if its bid is accepted.
- 11.2 Bidder must possess and provide evidence of its capability and the experience as stipulated in Bidding Data and the Qualification Criteria mentioned in the Bidding Documents.

### **IB.12 Documents Establishing Works' Conformity to Bidding Documents**

- 12.1 The documentary evidence of the Works 'conformity to the Bidding Documents may be in the form of literature, drawings and data and the bidder shall furnish documentation as set out in Bidding Data.
- 12.2 The bidder shall note that standards for workmanship, material and equipment, and references to brand names or catalogue numbers, if any, designated by the Procuring Agency in the Technical Provisions are intended to be descriptive only and not restrictive.

### **IB.13 Bid Security**

- 13.1 Bid Security of fixed amount as mentioned against the each work in the form of Call Deposit / Pay Order / Demand Draft / Bank Guarantee issued by a scheduled Bank of Pakistan in favor of "**Construction / Re-Construction of Existing Schools in Sindh affected under Rain / Flood 2022**" (must be attached with Technical documents of E-Bid & also be uploaded to the EPAD website) (Amended in Rule-37 for sub-rule(1) of SPPRA vide Notification Dated: 25<sup>th</sup> August 2025).
- 13.2 Any bid not accompanied by an acceptable Bid Security shall be rejected by the Procuring Agency as non-responsive.
- 13.3 The bid securities of unsuccessful bidders will be returned upon award of contract to the successful bidder or on the expiry of validity of Bid Security whichever is earlier.
- 13.4 The Bid Security of the successful bidder will be returned when the bidder has furnished the required Performance Security, and signed the Contract Agreement (SPP Rule 37).
- 13.5 The Bid Security may be forfeited:
- (a) if a bidder withdraws his bid during the period of bid validity; or
  - (b) if a bidder does not accept the correction of his Bid Price, pursuant to Sub-Clause

- 16.4 (b) hereof; or
- (c) in the case of a successful bidder, if he fails within the specified time limit to:
  - (i) furnish the required Performance Security or
  - (ii) sign the Contract Agreement.

#### **IB.14 Validity of Bids, Format, Signing and Submission of Bid**

- 14.1 Bids shall remain valid for the period stipulated in the Bidding Data after the date of bid opening.
- 14.2 In exceptional circumstances, Procuring Agency may request the bidders to extend the period of validity for an additional period but not exceeding 1/3 of the original period. The request and the bidders' responses shall be made in writing or by cable. A Bidder may refuse the request without forfeiting the Bid Security. A Bidder agreeing to the request will not be required or permitted to otherwise modify the Bid, but will be required to extend the validity of Bid Security for the period of the extension, and in compliance with IB.13 in all respects (SPP Rule 38).
- 14.3 All Schedules to Bid are to be properly completed and signed.
- 14.4 No alteration is to be made in the Form of Bid except in filling up the blanks as directed. If any alteration be made or if these instructions be not fully complied with, the bid may be rejected.
- 14.5 Each bidder shall prepare Original and number of copies specified in the Bidding Data of the documents comprising the bid as described in IB.8 and clearly mark them -ORIGINAL and -COPY as appropriate. In the event of discrepancy between them, the original shall prevail.
- 14.6 The original and all copies of the bid shall be typed or written in indelible ink and shall be signed by a person or persons duly authorized to sign (in the case of copies, Photostats are also acceptable). This shall be indicated by submitting a written Power of Attorney authorizing the signatory of the bidder to act for and on behalf of the bidder. All pages of the bid shall be initialed and official seal be affixed by the person or persons signing the bid.
- 14.7 The Bid shall be delivered in person or sent by registered mail at the address to Procuring Agency as given in Bidding Data.

## **D. SUBMISSION OF BID**

### **IB.15 Deadline for Submission, Modification & Withdrawal of Bids**

- 15.1 Bids must be received by the Procuring Agency at the address/provided in Bidding Data not later than the time and date stipulated therein.
- 15.2 The inner and outer envelopes shall
- (a) be addressed to the Procuring Agency at the address provided in the Bidding Data;
  - (b) bear the name and identification number of the Contract as defined in the Bidding and Contract Data; and
  - (c) provide a warning not to open before the specified time and date for Bid opening as defined in the Bidding Data.
  - (d) in addition to the identification required in 15.2, the inner envelopes shall indicate the name and address of the Bidder to enable the Bid to be returned unopened in case it is declared late.
  - (e) If the outer envelope is not sealed and marked as above, the Procuring Agency will assume no responsibility for the misplacement or premature opening of the Bid.
- 15.3 Bids submitted through telegraph, telex, fax or e-mail shall not be considered.
- 15.4 Any bid received by the Procuring Agency after the deadline for submission prescribed in Bidding Data will be returned unopened to such bidder.
- 15.5 Any bidder may modify or withdraw his bid after bid submission provided that the modification or written notice of withdrawal is received by the Procuring Agency prior to the deadline for submission of bids.
- 15.6 Withdrawal of a bid during the interval between the deadline for submission of bids and the expiration of the period of bid validity specified in the Form of Bid may result in forfeiture of the Bid Security pursuant to IB.13.5 (a).

## E. BID OPENING AND EVALUATION

### IB.16 Bid Opening, Clarification and Evaluation (SPP Rules 41, 42 & 43)

- 16.1 The Procuring Agency will open the bids, in the presence of bidders' representatives who choose to attend, at the time, date and in the place specified in the Bidding Data.
- 16.2 The bidder's name, Bid Prices, any discount, the presence or absence of Bid Security, and such other details as the Procuring Agency at its discretion may consider appropriate, will be announced by the Procuring Agency at the bid opening. The Procuring Agency will record the minutes of the bid opening. Representatives of the bidders who choose to attend shall sign the attendance sheet.

Any Bid Price or discount which is not read out and recorded at bid opening will not be taken into account in the evaluation of bid.

- 16.3 To assist in the examination, evaluation and comparison of Bids the Engineer/Procuring Agency may, at its discretion, ask the bidder for a clarification of its Bid. The request for clarification and the response shall be in writing and no change in the price or substance of the Bid shall be sought, offered or permitted (SPP Rule 43).
- 16.4 (a) Prior to the detailed evaluation, pursuant to IB.16.7 to 16.9, the Engineer/Procuring Agency will determine the substantial responsiveness of each bid to the Bidding Documents. For purpose of these instructions, a substantially responsive bid is one which conforms to all the terms and conditions of the Bidding Documents without material deviations. It will include determining the requirements listed in Bidding Data.
- (b) Arithmetical errors will be rectified on the following basis:  
If there is a discrepancy between the unit price and total price that is obtained by multiplying the unit price and quantity, the unit price shall prevail and the total price shall be corrected. If there is a discrepancy between the words and figures the amount in words shall prevail. If there is a discrepancy between the Total Bid price entered in Form of Bid and the total shown in Schedule of Prices-Summary, the amount stated in the Form of Bid will be corrected by the Procuring Agency in accordance with the Corrected Schedule of Prices.

If the bidder does not accept the corrected amount of Bid, his Bid will be rejected and his Bid Security forfeited.

- 16.5 A Bid determined as substantially non-responsive will be rejected and will not subsequently be made responsive by the bidder by correction of the non-conformity.
- 16.6 Any minor informality or non-conformity or irregularity in a Bid which does not constitute a material deviation (**major deviation**) may be waived by Procuring Agency, provided such waiver does not prejudice or affect the relative ranking of any other bidders.

**(A). Major (material) Deviations include: -**

- (i) has been not properly signed;
- (ii) is not accompanied by the bid security of required amount and manner;
- (iii) stipulating price adjustment when fixed price bids were called for;
- (iv) failing to respond to specifications;
- (v) failing to comply with Mile-stones/Critical dates provided in Bidding Documents;
- (vi) sub-contracting contrary to the Conditions of Contract specified in Bidding Documents;
- (vii) refusing to bear important responsibilities and liabilities allocated in the Bidding Documents, such as performance guarantees and insurance coverage;
- (viii) taking exception to critical provisions such as applicable law, taxes and duties and dispute resolution procedures;
- (ix) a material deviation or reservation is one:
  - (a) which affect in any substantial way the scope, quality or performance of the works;
  - (b) adoption/rectification whereof would affect unfairly the competitive position of other bidders presenting substantially responsive bids.

**(B) Minor Deviations**

Bids that offer deviations acceptable to the Procuring Agency and which can be assigned a monetary value may be considered substantially responsive at least as to the issue of fairness. This value would however be added as an adjustment for evaluation purposes only during the detailed evaluation process.

- 16.7 The Engineer/Procuring Agency will evaluate and compare only the bids previously determined to be substantially responsive pursuant to IB.16.4 to 16.6 as per requirements given hereunder. Bids will be evaluated for complete scope of works. The prices will be compared on the basis of the Evaluated Bid Price pursuant to IB.16.8 herein below.

**Technical Evaluation:** It will be examined in detail whether the works offered by the bidder complies with the Technical Provisions of the Bidding Documents. For this purpose, the bidder 's data submitted with the bid in Schedule B to Bid will be compared with technical features/criteria of the works detailed in the Technical Provisions. Other technical information submitted with the bid regarding the Scope of Work will also be reviewed.

- 16.8 Evaluated Bid Price

In evaluating the bids, the Engineer/Procuring Agency will determine for each bid in addition to the Bid Price, the following factors (adjustments) in the manner and to the extent indicated below to determine the Evaluated Bid Price:

- (i) making any correction for arithmetic errors pursuant to IB.16.4 hereof.
- (ii) discount, if any, offered by the bidders as also read out and recorded at the time of bid opening.
- (iii) excluding **provisional sums** and the provisions for **contingencies** in the Bill of Quantities **if any**, but including **Day work**, where priced competitively.

## **IB.17 Process to be Confidential**

17.1 Subject to IB.16.3 heretofore, no bidder shall contact Engineer/Procuring Agency on any matter relating to its Bid from the time of the Bid opening to the time the bid evaluation result is announced by the Procuring Agency. The evaluation result shall be announced at least seven (07) days prior to award of Contract (SPP Rule 45). The announcement to all bidders will include table(s) comprising read out prices, discounted prices, price adjustments made, final evaluated prices and recommendations against all the bids evaluated.

17.2 Any effort by a bidder to influence Engineer/Procuring Agency in the Bid evaluation, bid comparison or Contract Award decisions may result in the rejection of his Bid. Whereas any bidder feeling aggrieved, may lodge a written complaint to Complaint Redressal Committee as per terms and conditions mentioned in SPP Rules 31 & 32. However, mere fact of lodging a complaint shall not warrant suspension of procurement process.

17.3 Bidders may be excluded if involved in **“Corrupt and Fraudulent Practices”** means either one or any combination of the practices given below SPP Rule2(q);

Ⓜ **-Coercive Practice** means any impairing or harming, or threatening to impair or harm, directly or indirectly, any party or the property of the party to influence the actions of a party to achieve a wrongful gain or to cause a wrongful loss to another party;

Ⓜ **-Collusive Practice** means any arrangement between two or more parties to the procurement process or contract execution, designed to achieve with or without the knowledge of the procuring agency to establish prices at artificial, noncompetitive levels for any wrongful gain;

Ⓜ **“Corrupt Practice”** means the offering, giving, receiving or soliciting, directly or indirectly, of anything of value to influence the acts of another party for wrongful gain;

Ⓜ **-Fraudulent Practice” means** any act or omission, including a misrepresentation, that knowingly or recklessly misleads, or attempts to mislead, a party to obtain a financial or other benefit or to avoid an obligation;

Ⓜ **“Obstructive Practice”** means harming or threatening to harm, directly or indirectly, persons or their property to influence their participation in a procurement process, or affect the execution of a contract or deliberately destroying, falsifying, altering or concealing of evidence material to the investigation or making false statements before investigators in order to materially impede an investigation into allegations of a corrupt, fraudulent, coercive or collusive practice; or threatening, harassing or intimidating any party to prevent it from disclosing its knowledge of matters relevant to the investigation or from pursuing the investigation, or acts intended to materially impede the exercise of inspection and audit rights provided for under the Rules.

## **F. AWARD OF CONTRACT**

### **IB.18. Post Qualification**

18.1 The Procuring Agency, at any stage of the bid evaluation, having credible reasons for or *prima facie* evidence of any defect in contractor 's capacities, may require the contractors to provide information concerning their professional, technical, financial, legal or managerial competence whether already pre-qualified or not:

Provided, that such qualification shall only be laid down after recording reasons therefore in writing. They shall form part of the records of that bid evaluation report.

18.2 The determination will take into account the bidder 's financial and technical capabilities. It will be based upon an examination of the documentary evidence of the bidders 'qualifications submitted under B.11, as well as such other information required in the Bidding Documents.

### **IB.19 Award Criteria & Procuring Agency's Right**

19.1 Subject to IB.19.2, the Procuring Agency will award the Contract to the bidder whose the bid determined to be the Most Advantageous though not necessarily the lowest submitted price shall be accepted (As per Rule-49 of SPPRA Rules-2010 (amended time to time)., provided that such bidder has been determined to be qualified to satisfactory perform the Contract in accordance with the provisions of the IB.18.

19.2 Notwithstanding IB.19.1, the Procuring Agency reserves the right to accept or reject any bid, and to annul the bidding process and reject all bids, at any time prior to award of Contract, without thereby incurring any liability to the affected bidders or any obligation to inform the affected bidders of the grounds for the Procuring Agency's action except that the grounds for its rejection of all bids shall upon request be communicated, to any bidder who submitted a bid, without justification of the grounds. Notice of the rejection of all the bids shall be given promptly to all the bidders (SPP Rule 25).

### **IB.20 Notification of Award & Signing of Contract Agreement**

20.1 Prior to expiration of the period of bid validity prescribed by the Procuring Agency, the Procuring Agency will notify the successful bidder in writing (Letter of Intent) that his bid has been accepted (SPP Rule 49).

20.2 Within seven (07) days from the date of furnishing of acceptable Performance Security under the Conditions of Contract, the Procuring Agency will send the successful bidder the Form of Contract Agreement provided in the Bidding Documents, incorporating all agreements between the parties.

20.3 The formal Agreement between the Procuring Agency and the successful bidder duly stamped at rate of 0.35% of bid price (updated from time to time) stated in Letter of Acceptance shall be executed within seven (07) days of the receipt of Form of Contract Agreement by the successful bidder from the Procuring Agency.

## **IB.21 Performance Security**

- 21.1 The successful bidder shall furnish to the Procuring Agency a Performance Security in the form and the amount stipulated in the Conditions of Contract within a period of fourteen (14) days after the receipt of Letter of Acceptance (SPP 39).
- 21.2 Failure of the successful bidder to comply with the requirements of Sub-Clauses IB.20.2 & 20.3 or 21.1 or Clause IB.22 shall constitute sufficient grounds for the annulment of the award and forfeiture of the Bid Security.
- 21.3 Publication of Award of Contract: within seven days of the award of contract, the procuring shall publish on the website of the authority and on its own website, if such a website exists, the results of the bidding process, identifying the bid through procurement identifying Number if any and the following information:
- (1) Evaluation Report;
  - (2) Form of Contract and letter of Award;
  - (3) Bill of Quantities or Schedule of Requirements. (SPP Rule 50)

**IB.22 Integrity Pact** the Bidder shall sign and stamp the Form of Integrity Pact provided at Schedule-F to Bid in the Bidding Document for all Sindh Government procurement contracts exceeding Rupees ten (10) million. Failure to provide such Integrity Pact shall make the bid non-responsive (SPP Rule 89).

# **BIDDING DATA**

## Contact/Bidding Data

(This section should be filled in by the procuring agency before issuance of the bidding documents.) The following specific data for the works to be tendered shall complement, amend, or supplement the provisions in the Instructions to Bidders. Wherever there is a conflict, the provisions herein shall prevail over those in the Instructions to Bidders.

Instructions to Bidders Clause Reference

- 1.1 Name and address of the procuring agency:  
**Project Director, ADP Scheme # 2941 of 2024-25 & 2301 of 2025-26 “Construction / Re-Construction of Existing Schools in Sindh Affected under Rain / Flood 2022 in Sindh (833 Units)”, School Education & Literacy Department, Government of Sindh, @ 2<sup>nd</sup> Floor, Old KDA Building, Sindh Secretariat No. 3, Karachi**
- 1.2 Name of the Project and Summary of the works:  
**Construction / Re-Construction of Existing Schools in Sindh Affected under Rain / Flood 2022 in Sindh (833 Units) (ADP No. 2941 of 2024-25)”**  
**PACKAGE-49 DISTRICT KAMBAR SHAHDADKOT (2 UNITS)**
- 2.1 Name of the Borrower/Source of Financing/Funding Agency/Funding Source;  
**ADP NO. 2941 / 2301 (Co sharing scheme PSDP / ADP)**
- 2.1 Amount and Type of Financing/Scheme Cost and Allocated Funds.  
**ESTIMATED COST RS. 33.549 MILLION**
- 8.1 Time limit for clarification:  
The written clarification should upload at EPAD Portal on any working day but not later than 05 working days prior to last date of submission.
- 10.1 Bid language:  
**National Competitive Bidding.**
- 11.1 (a) Prequalification Information to be updated (where applicable): **N.A**  
**SINGLE-STAGE, TWO-ENVELOPE**
- Financial Criteria:**
- 11.1 (b) Financial and Technical Proposal (*in case of two envelope method*) or Company Profile in single stage single envelope:  
  
The bidder has to submit a technical proposal in sufficient detail to demonstrate the adequacy of the bid in meeting requirements for timely completion of the works.
- 13.1 *Bidders to quote entirely in Pak. rupees but specify the percentages of foreign currency they require, if applicable.*
- 14.1 Period of Bid Validity:  
**90 Days**
- 15.1 Amount of Bid Security:  
**Rs. 1.675 Million.**

- 17.1 Venue, time, and date of the pre-Bid meeting:
- 18.4 Number of copies of the bid to be completed and returned: To be uploaded on EPAD System
- 19.2 (a) Procuring Agency's address for the purpose of bid opening via EPAD System:  
**Project Director, ADP Scheme # 2941 of 2024-25 "Construction / Re-Construction of Existing Schools in Sindh Affected under Rain / Flood 2022 in Sindh (833 Units)", School Education & Literacy Department, Government of Sindh, @ 2<sup>nd</sup> Floor, Old KDA Building, Sindh Secretariat No. 3, Karachi**
- (a) Name and Identification Number of the Contract:  
**Construction / Re-Construction of Existing Schools in Sindh Affected under Rain / Flood 2022 in Sindh (833 Units) (ADP No. 2941 of 2024-25)"**  
**PACKAGE-49 District Kambar Shahdadkot (2 Units)**
- 20.1 (a) Deadline for submission / uploading of bids:  
**Date: 02.06.2026 till 11:00 A.M.**
- (b) Venue, time, and date of bid opening:  
**Date: 02.06.2026 @ 11:30 A.M. via EPAD System at Office of the Director General (PD&R) / Project Director, ADP Scheme # 2941 of 2024-25 "Construction / Re-Construction of Existing Schools in Sindh Affected under Rain / Flood 2022 in Sindh (833 Units)", School Education & Literacy Department, Government of Sindh, @ 2<sup>nd</sup> Floor, Old KDA Building, Sindh Secretariat No. 3, Karachi**
- 32.1 Standard form and amount of Performance Security acceptable to the procuring agency:  
**10% of contract price.**
- 32.3 Stamp duty  
**0.35% of the contract price** will be paid by successful bidder as stamp duty.

**Note: All conditions given in the Bidding Data are Mandatory for Eligibility**

**EVALUATION /  
QUALIFICATION  
CRITERIA**

### **Eligibility Criteria (Mandatory):**

1. Valid Copy of CNIC of Proprietor / Partners
2. Bid Security / Earnest Money should be made from the Account of the Company / Firm of the participant.
3. Bid should be signed along-with company's stamp on each page of financial & technical documents.
4. Valid Registration with Pakistan Engineering Council (PEC) in Category C-5 or above having specialization code EE04, CE09 & CE10.
5. Valid Electrical License of Government of Sindh for Electrical Works for concerned Region must be provided.
6. Bidder shall be an active Tax Payer List (ATL) of Federal Board of Revenue (FBR) or Sindh Revenue Board (SRB) as the case may be. Failing to which the bidder shall not be eligible to take part in bid in accordance with Rule-46 sub rule (1) clause (a) sub clause (iii) of SPP Rules-2010 (Amended till to date).
7. Proof of experience and details of similar nature of work(s) executed during last five years indicating the name of project / scheme / works with cost, date of commencement & completion in accordance with amendments in SPPRA Regulations Clause # 2.16, 7.9(i) vide Notification Dated: 10<sup>th</sup> April, 2023 (With Satisfactory Completion Certificate duly supported by documentary evidences viz: Work orders / Contract Agreements & Satisfactory Project Completion Certificates by concerned Department), the information about experiences of work(s) executed previously can also be verified from SPPRA web site:
  - a. At least one similar nature of work having minimum cost 80% of the estimated cost of work; OR
  - b. At least two similar nature works each having minimum cost 50% of the estimated cost.
8. Average Annual Financial Turn-over not less than equivalent cost of the scheme / project during last five years duly supported by the Bank Statement, Annual Tax Returns & Audit report (last 5 years each) in accordance with amendments made in SPPRA Regulations Clause # 2.16, 7.9(i) vide Notification Dated: 10<sup>th</sup> April, 2023. These must be issued by Chartered Accountant firms registered with ICAP (Institute of Chartered Accountants of Pakistan). Statement from any other firms will not be accepted.
9. Bio-data of the technical staff permanently employed with evidence and available with the firm / contractor (Attach evidence of proposed staff) (List is mentioned in bidding documents).
10. List of Equipment, Machinery, Vehicles, available with the contractor for this job with location (Details of ownership / hired) (List is mentioned in bidding documents).
11. Undertaking on Original E-Stamp Paper of Rs. 500/- containing that:
  - i. The firm was not involved in any litigation, no work was rescinded in the past (List of cases entered into arbitration / litigation & list of works where penalty is involved, if any must be attached).
  - ii. The firm was not black listed (Attach all details if any). Not doing so will result in rejection of tender.
  - iii. The information / documents submitted are correct and true.

**QUALIFICATION CRITERIA BASED ON MARKS / SCORE:**

The aggregate qualifying score is 80%. However, it is mandatory for each bidder to obtain at least 50% marks in each individual section. To be technically qualified, bidders must achieve a cumulative score of 80% while also meeting the mandatory criteria for experience record and production capacity. Failure to satisfy these mandatory criteria will result in disqualification, regardless of the overall score.

<b>(A) COMPANY PROFILE:</b>			<b>10 MARKS</b>
			<b>Total Marks</b>
	<b>I.</b>	<b>Period since Firm/Contractor is in construction business</b>	<b>7</b>
	i.	Up to 10 years	<b>3</b>
	ii.	Up to 15 years	<b>5</b>
	iii.	Above 15 years	<b>7</b>
	<b>II.</b>	<b>Office facilities</b>	<b>3</b>
	i.	In Sindh province	<b>2</b>
	ii.	Extra for other Province / Islamabad	<b>1</b>
		<b>TOTAL (A):</b>	<b>10</b>
<b>(B) General Experience Record</b>			<b>25 Marks</b>
	<b>i.</b>	At least one similar nature of work having minimum cost 80% or two similar nature of works having minimum cost of 50% of the estimated cost of work completed during last 5 years (Attached satisfactory Completion Certificates which are mandatory)	<b>15</b>
	<b>ii.</b>	5 Marks Each for more than one work completed during last 5 years (Maximum 25 Marks)	<b>10</b>
		<b>TOTAL (B):</b>	<b>25</b>
<b>(C) Financial Soundness /Status</b>			<b>25 Marks</b>
	<b>I.</b>	<b>Working Capital in hand for this project/work</b>	<b>15</b>
		(Attach proof of Bank Statements within 30 days / Credit Facilities)	
	i.	Upto 15 Million	<b>10</b>
	ii.	Above 15 Million to 35 Million	<b>12</b>
	iii.	Above 35 Million	<b>15</b>
		<b>Sub-Total (I)</b>	<b>15</b>
	<b>II.</b>	<b>Average Annual Financial Turn-over during last 5 years</b>	<b>10</b>
	i.	Not less than equivalent cost of the scheme / project up-to 35.000 Million	<b>5</b>
	ii.	35 Million to 50 Million	<b>7</b>
	iii.	Above 50 Million	<b>10</b>
		<b>Sub-Total (II)</b>	<b>10</b>
		<b>TOTAL (C)</b>	<b>25</b>

<b>D) Personnel Capabilities required for this project</b>		<b>25 Marks</b>
1	<b>Project Manager must be B.E. (Civil) registered with PEC (01 No.)</b>	<b>10</b>
	Minimum 10 years of experience	<b>7</b>
	More than 10 years of experience	<b>10</b>
2	<b>Quantity Surveyor with DAE / B. Tech (Civil) (01 No.)</b>	<b>6</b>
	Minimum 10 Years of experience	<b>4</b>
	More than 10 years of experience.	<b>6</b>
3	<b>Site Supervisor (Civil) with DAE / B. Tech (01 No.)</b>	<b>6</b>
	Minimum 10 years of experience	<b>4</b>
	More than 10 years of experience	<b>6</b>
4	<b>Site Supervisor (Electrical) with DAE / B. Tech (01 No.)</b>	<b>3</b>
	Minimum 10 years of experience	<b>2</b>
	More than 10 years of experience	<b>3</b>
	<b>TOTAL (D)</b>	<b>25</b>
<b>(E) Equipment Capability</b>		<b>15 Marks</b>
1	Concrete Vibrator (02 Nos.)	<b>2</b>
2	Water Pumps (02 Nos.)	<b>2</b>
3	Mixture Machine with Tower Lift (02 Nos.)	<b>2</b>
4	Dumper / Trucks (02 Nos.)	<b>2</b>
5	Tractor Trolley (02 Nos.)	<b>2</b>
6	Shuttering / Scaffolding (Formwork) (10,000 Sft.)	<b>2</b>
7	Generator 10 KVA (02 Nos.)	<b>2</b>
8	Power / Hand Tools-Safety Equipment-measuring & testing Equipment (L.S)	<b>1</b>
	<b>TOTAL (E)</b>	<b>15</b>
	<b>G. TOTAL MARKS:</b>	<b>100</b>

**Note:**

1. Satisfactory Completion Certificates duly supported by Work Orders, Contract Agreements issued by the concerned Department, these may be verified through the SPPRA website.
2. Bank Statements, Annual Tax Returns, and Audit Reports for the last five (05) years, Audit Reports must be issued by Chartered Accountant firms registered with ICAP (Institute of Chartered Accountants of Pakistan). Supporting documents must include Bank's Letter and Account balance details to ascertain bidder's cash flow & Bank Credit Line Certificate.
3. Proof of permanently employed technical staff, supported by CVs, Degrees, PEC Registration Cards, Salary Proof, etc. Provide acceptable details of staff along with working history of the last five (05) years with the firm. Payroll records must be duly attested by the competent authority. Submission of documentary evidence is mandatory.
4. Details of Equipment, Machinery, and Vehicles available with the contractor for the project. Proof of ownership documents or valid rental/hiring agreements must be provided. Failure to submit documentary evidence of ownership or rental agreements will result in disqualification.
5. The bidder must upload duly filled, signed, and company-stamped copies of each page of the Standard Bidding Documents downloaded by the firm. All financial and technical documents must also be signed and stamped. Failure to comply will render the bid non-responsive and it shall not be considered for evaluation.

**FORM OF  
BID AND  
SCHEDULE TO BID**

**FORM OF BID**  
(LETTER OF OFFER)

Bid Reference No. \_\_\_\_\_  
\_\_\_\_\_

\_\_\_\_\_  
(Name of Works)

To:

\_\_\_\_\_  
\_\_\_\_\_  
\_\_\_\_\_

Gentlemen,

1. Having examined the Bidding Documents including Instructions to Bidders, Bidding Data, Conditions of Contract, Contract Data, Specifications, Drawings, if any, Schedule of Prices and Addenda Nos.  
\_\_\_\_\_ for the execution of the above-named works, we, the undersigned, being a company doing business under the name of and address \_\_\_\_\_ and being duly incorporated under the laws of Pakistan hereby offer to execute and complete such works and remedy any defects therein in conformity with the said Documents including Addenda thereto for the Total Bid Price of Rs \_\_\_\_\_ (Rupees \_\_\_\_\_) or such other sum as may be ascertained in accordance with the said Documents.
2. We understand that all the Schedules attached hereto form part of this Bid.
3. As security for due performance of the undertakings and obligations of this Bid, we submit herewith a Bid Security in the amount of \_\_\_\_\_ drawn in your favour or made payable to you and valid for a period of twenty-eight (28) days beyond the period of validity of Bid.
4. We undertake, if our Bid is accepted, to commence the Works and to deliver and complete the Works comprised in the Contract within the time(s) stated in Contract Data.
5. We agree to abide by this Bid for the period of \_\_\_\_\_ days from the date fixed for receiving the same and it shall remain binding upon us and may be accepted at any time before the expiration of that period.
6. Unless and until a formal Agreement is prepared and executed, this Bid, together with your written acceptance thereof, shall constitute a binding contract between us.
7. We undertake, if our Bid is accepted, to execute the Performance Security

referred to in Conditions of Contract for the due performance of the Contract.

8. We understand that you are not bound to accept the lowest or any bid you may receive.
9. We do hereby declare that the Bid is made without any collusion, comparison of figures or arrangement with any other person or persons making a bid for the Works.

Dated this \_\_\_\_\_ day of \_\_\_\_\_, 20

Signature \_\_\_\_\_

in the capacity of \_\_\_\_\_ duly authorized to sign bid for and on behalf of

\_\_\_\_\_  
*(Name of Bidder in Block Capitals)*

*(Seal)*

Address

\_\_\_\_\_  
\_\_\_\_\_  
\_\_\_\_\_

Witness:

(Signature) \_\_\_\_\_

Name: \_\_\_\_\_

Address: \_\_\_\_\_

\_\_\_\_\_

**[SCHEDULES TO BID INCLUDE THE FOLLOWING:**

- Schedule A to Bid: Schedule of Prices
- Schedule B to Bid: Specific Works Data
- Schedule C to Bid: Works to be Performed by Subcontractors
- Schedule D to Bid: Proposed Program of Works
- Schedule E to Bid: Method of Performing Works
- Schedule F to Bid: Integrity Pact]

**SCHEDULE – A TO BID**

**SCHEDULE OF PRICES**

<b><u>Sr. No.</u></b>		<b><u>Page No.</u></b>
1.	Preamble to Schedule of Prices.....	24
2.	Schedule of Prices.....	26
	* (a) Summary of Bid Prices	
	* (b) Detailed Schedule of Prices /Bill of Quantities (BOQ)	
	<i>* [To be prepared by the Engineer/Procuring Agency]</i>	

**PREAMBLE TO SCHEDULE OF PRICES**

**1. General**

- 1.1 The Schedule of Prices shall be read in conjunction with the Conditions of Contract, Contract Data together with the Specifications and Drawings, if any.
- 1.2 The Contract shall be for the whole of the works as described in these Bidding Documents. Bids must be for the complete scope of works.

**2. Description**

- 2.1 The general directions and descriptions of works and materials are not necessarily repeated nor summarized in the Schedule of Prices. References to the relevant sections of the Bidding Documents shall be made before entering prices against each item in the Schedule of Prices.

**3. Units & Abbreviations**

- 3.1 Units of measurement, symbols and abbreviations expressed in the Bidding Documents shall comply with the System International d'Unites (SI Units).

\_\_\_\_\_  
\_\_\_\_\_

*(Note: The abbreviations to be used in the Schedule of Prices to be defined by the Procuring Agency).*

**4. Rates and Prices**

- 4.1 Except as otherwise expressly provided under the Conditions of Contract, the rates and amounts entered in the Schedule of Prices shall be the rates at which the Contractor shall be paid and shall be the full inclusive value of the works set forth or implied in the Contract; except for the amounts reimbursable, if any to the Contractor under the Contract.
- 4.2 Unless otherwise stipulated in the Contract Data, the premium, rates and prices entered by the bidder shall not be subject to adjustment during the performance of the Contract.
- 4.3 All duties, taxes and other levies payable by the Contractor shall be included in the rates and prices.
- 4.4 The whole cost of complying with the provisions of the Contract shall be included in the items provided in the Schedule of Prices, and where

## SCHEDULE - A TO BID

no items are provided, the cost shall be deemed to be distributed among the rates and prices entered for the related items of the Works and no separate payment will be made for those items.

The rates, prices and amounts shall be entered against each item in the Schedule of Prices. Any item against which no rate or price is entered by the bidder will not be paid for by the Procuring Agency when executed and shall be deemed covered by the rates and prices for other items in the Schedule of Prices.

- 4.5 (a) The bidder shall be deemed to have obtained all information as to and all requirements related thereto which may affect the bid price.

\*(b) The Contractor shall be responsible to make complete arrangements for the transportation of the Plant to the Site.

*\*(Procuring Agency may modify as appropriate)*

- 4.6 The Contractor shall provide for all parts of the Works to be completed in every respect. Notwithstanding that any details, accessories, etc. required for the complete installation and satisfactory operation of the Works, are not specifically mentioned in the Specifications, such details shall be considered as included in the Contract Price.

### **5. Bid Prices**

#### 5.1 Break-up of Bid Prices

The various elements of Bid Prices shall be quoted as detailed by the Procuring Agency in the format of Schedule of Prices.

The bidder shall recognize such elements of the costs which he expects to incur the performance of the Works and shall include all such costs in the rates and amounts entered in the Schedule of Prices.

#### 5.2 Total Bid Price

The total of bid prices in the Schedule of Prices shall be entered in the Summary of Bid Prices.

### **6. Provisional Sums and Day work**

- 6.1 Provisional Sums included and so designated in the Schedule of Prices if any, shall be expended in whole or in part at the direction and discretion of the Engineer/Procuring Agency. The Contractor will only receive payment in respect of Provisional Sums, if he has been instructed by the Engineer/Procuring Agency to utilize such sums.

- 6.2 Day work rates in the contractor 's bid are to be used for small additional amounts of work and only when the Engineer have given written instructions in advance for additional work to be paid for in that way.

SCHEDULE OF PRICES – SUMMARY OF BID PRICES (Sample)

Bill No.	Description	Total Amount (Rs)
	<p><b>(A) Building Work</b></p> <p>1. Civil works</p> <p>2. Internal sanitary and water supply</p> <p>3. Electrification</p> <p>4. External Development works</p> <p>5. Miscellaneous Items</p> <p><b>(B) Road Work.</b></p> <p>1. Earthwork</p> <p>2. Hard Crust and Surface Treatment</p> <p>3. Culverts and Bridges</p> <p>4. Miscellaneous Items</p> <p><b>(C) Public Health Engineering Works.</b></p> <p>1. Earthwork</p> <p>2. Subsurface Drains</p> <p>3. Pipe Laying and Man holes</p> <p>4. Tube wells, Pump houses</p> <p>5. Compound wall</p> <p>6. Miscellaneous Items</p>	
	<p>Total Bid Price (The amount to be entered in Paragraph 1 of the Form of Bid) (In words).</p>	

SCHEDULE OF PRICES

Item No.	Description	Quantity	Unit Rate(Rs)	Total Amount (Rs)
1. 2. 3.	<b>I. (Civil works)</b>			
1. 2. 3.	<b>II. Internal sanitary and water supply.</b>			
1. 2. 3.	<b>III. Electrification.</b>			
1. 2. 3.	<b>IV. External Development works.</b>			
1. 2. 3.	<b>V. Miscellaneous Items</b>			
<p>Total (to be carried to Summary of Bid Price)            Add/ Deduct the percentage quoted above/below on the prices of items based on Composite Schedule of Rates.</p>				

**SCHEDULE - B TO BID**

**\*SPECIFIC WORKS DATA**

*(To be prepared and incorporated by the Procuring Agency)*

*\*(Note: The Procuring Agency shall spell out the information & data required to be filled out by the bidder and to furnish complementary information).*

**SCHEDULE – C TO BID**

**WORKS TO BE PERFORMED BY SUBCONTRACTORS\***

The bidder will do the work with his own forces except the work listed below which he intends to sub-contract.

Items of Works to be Sub-Contracted	Name and address of Sub-Contractors	Statement of similar works previously executed. ( <i>attach evidence</i> )
--	--	--

**Note:**

- \* *The Procuring Agency should decide whether to allow subcontracting or not. In case Procuring Agency decides to allow subcontracting then following conditions shall be complied with:*
1. No change of Sub-Contractors shall be made by the bidder without prior approval of the Procuring Agency.
  2. The truthfulness and accuracy of the statement as to the experience of Sub-Contractors is guaranteed by the bidder. The Procuring Agency 's judgment shall be final as to the evaluation of the experience of Sub-Contractors submitted by the bidder.
  3. Statement of similar works shall include description, location & value of works, year completed and name & address of the clients.

## **SCHEDULE – D TO BID**

### **PROPOSED PROGRAMME OF WORKS**

Bidder shall provide a Programme in a bar-chart or Program Evaluation and Review Technique (PERT) or Critical Path Method (CPM) showing the sequence of work items by which he proposes to complete the works of the entire Contract. The Programme should indicate the sequence of work items and the period of time during which he proposes to complete the works including the activities like designing, schedule of submittal of drawings, ordering and procurement of materials, manufacturing, delivering, construction of civil works, erection, testing and commissioning of works to be supplied under the Contract.

## **SCHEDULE – E TO BID**

### **METHOD OF PERFORMING WORKS**

The bidder is required to submit a narrative outlining the method of performing the Works. The narrative should indicate in detail and include but not be limited to:

- The sequence and methods in which he proposes to carry out the Works, including the number of shifts per day and hours per shift, he expects to work.
- A list of all major items of construction and plant erection, tools and vehicles proposed to be used in delivering/carrying out the works at site.
- The procedure for installation of equipment and transportation of equipment and materials to the site.
- Organization chart indicating head office & field office personnel involved in management, supervision and engineering of the Works to be done under the Contract.

**SCHEDULE – F TO BID**

**(INTEGRITY PACT)**

**DECLARATION OF FEES, COMMISSION AND BROKERAGE ETC  
PAYABLE BY CONTRACTORS  
(FOR CONTRACTS WORTH RS. 10.00 MILLION OR MORE)**

Contract No. \_\_\_\_\_ Dated \_\_\_\_\_

Contract Value: \_\_\_\_\_

Contract Title: \_\_\_\_\_

..... [name of Contractor] hereby declares that it has not obtained or induced the procurement of any contract, right, interest, privilege or other obligation or benefit from Government of Sindh (GoS) or any administrative subdivision or agency thereof or any other entity owned or controlled by it (GoS) through any corrupt business practice.

Without limiting the generality of the foregoing, [name of Contractor] represents and warrants that it has fully declared the brokerage, commission, fees etc. paid or payable to anyone and not given or agreed to give and shall not give or agree to give to anyone within or outside Pakistan either directly or indirectly through any natural or juridical person, including its affiliate, agent, associate, broker, consultant, director, promoter, shareholder, sponsor or subsidiary, any commission, gratification, bribe, finder's fee or kickback, whether described as consultation fee or otherwise, with the object of obtaining or inducing the procurement of a contract, right, interest, privilege or other obligation or benefit in whatsoever form from, from Procuring Agency (PA) except that which has been expressly declared pursuant hereto.

[name of Contractor] accepts full responsibility and strict liability that it has made and will make full disclosure of all agreements and arrangements with all persons in respect of or related to the transaction with PA and has not taken any action or will not take any action to circumvent the above declaration, representation or warranty.

[name of Contractor] accepts full responsibility and strict liability for making any false declaration, not making full disclosure, misrepresenting facts or taking any action likely to defeat the purpose of this declaration, representation and warranty. It agrees that any contract, right, interest, privilege or other obligation or benefit obtained or procured as aforesaid shall, without prejudice to any other rights and remedies available to PA under any law, contract or other instrument, be voidable at the option of PA.

Notwithstanding any rights and remedies exercised by PA in this regard, [name of Supplier/Contractor/Consultant] agrees to indemnify PA for any loss or damage incurred by it on account of its corrupt business practices and further pay compensation to PA in an amount equivalent to ten times the sum of any commission, gratification, bribe, finder's fee or kickback given by [name of Contractor] as aforesaid for the purpose of obtaining or inducing the procurement of any contract, right, interest, privilege or other obligation or benefit in whatsoever form from PA.

.....  
[Procuring Agency]

[Contractor]

## **CONDITIONS OF CONTRACT**

**TABLE OF CONTENTS**

**CONDITIONS OF CONTRACT**

---

<b>Clause No</b>	<b>Description</b>	<b>Page No</b>
1.	General Provisions .....	35
2.	The Procuring Agency .....	37
3.	Engineer's/Procuring Agency's Representatives .....	37
4.	The Contractor .....	38
5.	Design by Contractor .....	38
6.	Procuring Agency's Risks .....	39
7.	Time for Completion.....	40
8.	Taking Over.....	41
9.	Remedying Defects.....	41
10.	Variations and Claims .....	41
11.	Contract Price And Payment.....	43
12.	Default.....	44
13.	Risks and Responsibilities .....	46
14.	Insurance .....	46
15.	Resolution of Disputes .....	47
16.	Integrity Pact .....	48

---

## CONDITIONS OF CONTRACT

### 1. GENERAL PROVISIONS

#### 1.1 Definitions

In the Contract as defined below, the words and expressions defined shall have the following meanings assigned to them, except where the context requires otherwise:

##### **The Contract**

1.1.1 -Contract<sup>1</sup> means the Contract Agreement and the other documents listed in the Contract Data.

1.1.2 -Specifications<sup>1</sup> means the document as listed in the Contract Data, including Procuring Agency 's requirements in respect of design to be carried out by the Contractor (if any), and any Variation to such document.

1.1.3 -Drawings<sup>1</sup> means the Procuring Agency 's drawings of the Works as listed in the Contract Data, and any Variation to such drawings.

##### **Persons**

1.1.4 -Procuring Agency<sup>1</sup> means the person named in the Contract Data and the legal successors in title to this person, but not (except with the consent of the Contractor) any assignee.

1.1.5 -Contractor<sup>1</sup> means the person named in the Contract Data and the legal successors in title to this person, but not (except with the consent of the Procuring Agency) any assignee.

1.1.6 -Party<sup>1</sup> means either the Procuring Agency or the Contractor.

##### **Dates, Times and Periods**

1.1.7 -Commencement Date<sup>1</sup> means the date fourteen (14) days after the date the Contract comes into effect or any other date named in the Contract Data.

1.1.8 -Day<sup>1</sup> means a calendar day

1.1.9 -Time for Completion<sup>1</sup> means the time for completing the Works as stated in the Contract Data (or as extended under Sub-Clause 7.3), calculated from the Commencement Date.

##### **Money and Payments**

1.1.10 -Cost<sup>1</sup> means all expenditure properly incurred (or to be incurred) by the Contractor, whether on or off the Site, including overheads and similar charges but does not include any allowance for profit.

##### **Other Definitions**

- 1.1.11 -Contractor 's Equipment<sup>l</sup> means all machinery, apparatus and other things required for the execution of the Works but does not include Materials or Plant intended to form part of the Works.
- 1.1.12 -Country<sup>l</sup> means the Islamic Republic of Pakistan.
- 1.1.13 -Procuring Agency 's Risks<sup>l</sup> means those matters listed in Sub-Clause 6.1.
- 1.1.14 -Force Majeure<sup>l</sup> means an event or circumstance which makes performance of a Party 's obligations illegal or impracticable and which is beyond that Party 's reasonable control.
- 1.1.15 Materials<sup>l</sup> means things of all kinds (other than Plant) to be supplied and incorporated in the Works by the Contractor.
- 1.1.16 -Plant<sup>l</sup> means the machinery and apparatus intended to form or forming part of the Works.
- 1.1.17 -Site<sup>l</sup> means the places provided by the Procuring Agency where the Works are to be executed, and any other places specified in the Contract as forming part of the Site.
- 1.1.18 -Variation<sup>l</sup> means a change which is instructed by the Engineer/Procuring Agency under Sub-Clause 10.1.
- 1.1.19 Works<sup>l</sup> means any or all the works whether Supply, Installation, Construction etc. and design (if any) to be performed by the Contractor including temporary works and any variation thereof.
- 1.1.20 -Engineer<sup>l</sup> means the person notified by the Procuring Agency to act as Engineer for the purpose of the Contract and named as such in Contract Data.

## **1.2 Interpretation**

Words importing persons or parties shall include firms and organizations. Words importing singular or one gender shall include plural or the other gender where the context requires.

## **1.3 Priority of Documents**

The documents forming the Contract are to be taken as mutually explanatory of one another. If an ambiguity or discrepancy is found in the documents, the priority of the documents shall be in accordance with the order as listed in the Contract Data.

#### **1.4 Law**

The law of the Contract is the relevant Law of Islamic Republic of Pakistan.

#### **1.5 Communications**

All Communications related to the Contract shall be in English language.

#### **1.6 Statutory Obligations**

The Contractor shall comply with the Laws of Islamic Republic of Pakistan and shall give all notices and pay all fees and other charges in respect of the Works.

### **2. THE PROCURING AGENCY**

#### **2.1 Provision of Site**

The Procuring Agency shall provide the Site and right of access thereto at the times stated in the Contract Data.

**Site Investigation Reports** are those that were included in the bidding documents and are factual and interpretative reports about the surface and subsurface conditions at the Site.

#### **2.2 Permits etc.**

The Procuring Agency shall, if requested by the Contractor, assist him in applying for permits, licenses or approvals which are required for the Works.

#### **2.3 Engineer's/Procuring Agency's Instructions**

The Contractor shall comply with all instructions given by the Procuring Agency or the Engineer, if notified by the Procuring Agency, in respect of the Works including the suspension of all or part of the works.

#### **2.4 Approvals**

No approval or consent or absence of comment by the Engineer/Procuring Agency shall affect the Contractor 's obligations.

### **3. ENGINEER'S/PROCURING AGENCY'S REPRESENTATIVES**

#### **3.1 Authorized Person**

The Procuring Agency shall appoint a duly authorized person to act for him and on his behalf for the purposes of this Contract. Such authorized person shall be duly identified in the Contract Data or otherwise notified in writing to the Contractor as soon as he is so appointed. In either case the Procuring Agency shall notify the Contractor, in writing, the precise scope of the authority of such authorized person at the time of his appointment.

### **3.2 Engineer's/Procuring Agency's Representative**

The name and address of Engineer 's/Procuring Agency 's Representative is given in Contract Data. However, the Contractor shall be notified by the Engineer/Procuring Agency, the delegated duties and authority before the Commencement of works.

## **4. THE CONTRACTOR**

### **4.1 General Obligations**

The Contractor shall carry out the works properly and in accordance with the Contract. The Contractor shall provide all supervision, labour, Materials, Plant and Contractor 's Equipment which may be required

### **4.2 Contractor's Representative**

The Contractor shall appoint a representative at site on full time basis to supervise the execution of work and to receive instructions on behalf of the Contractor but only after obtaining the consent of the Procuring Agency for such appointment which consent shall not be withheld without plausible reason(s) by the Procuring Agency. Such authorized representative may be substituted/ replaced by the Contractor at any time during the Contract Period but only after obtaining the consent of the Procuring Agency as aforesaid.

### **4.3 Subcontracting**

The Contractor shall not subcontract the whole of the works. The Contractor shall not subcontract any part of the works without the consent of the Procuring Agency.

### **4.4 Performance Security**

The Contractor shall furnish to the Procuring Agency within fourteen (14) days after receipt of Letter of Acceptance a Performance Security at the option of the bidder, in the form of Payee 's order /Bank Draft or Bank Guarantee from scheduled bank for the amount and validity specified in Contract Data.

## **5. DESIGN BY CONTRACTOR**

### **5.1 Contractor's Design**

The Contractor shall carry out design to the extent specified, as referred to in the Contract Data. The Contractor shall promptly submit to the Engineer/Procuring Agency all designs prepared by him, within fourteen (14) days of receipt the Engineer/Procuring Agency shall notify any comments or, if the design submitted is not in accordance with the Contract, shall reject it stating the reasons. The

Contractor shall not construct any element of the works designed by him within fourteen (14) days after the design has been submitted to the Engineer/Procuring Agency or which has been rejected. Design that has been rejected shall be promptly amended and resubmitted. The Contractor shall resubmit all designs commented on taking these comments into account as necessary.

## **5.2 Responsibility for Design**

The Contractor shall remain responsible for his bided design and the design under this Clause, both of which shall be fit for the intended purposes defined in the Contract and he shall also remain responsible for any infringement of any patent or copyright in respect of the same. The Engineer/Procuring Agency shall be responsible for the Specifications and Drawings.

## **6. PROCURING AGENCY'S RISKS**

### **6.1 The Procuring Agency's Risks**

The Procuring Agency 's Risks are: -

- a) war, hostilities (whether war be declared or not), invasion, act of foreign enemies, within the Country;
- b) rebellion, terrorism, revolution, insurrection, military or usurped power, or civil war, within the Country;
- c) riot, commotion or disorder by persons other than the Contractor 's personnel and other employees including the personnel and employees of Sub-Contractors, affecting the Site and/or the Works;
- d) ionizing radiations, or contamination by radio-activity from any nuclear fuel, or from any nuclear waste from the combustion of nuclear fuel, radio-active toxic explosive, or other hazardous properties of any explosive nuclear assembly or nuclear component of such an assembly, except to the extent to which the Contractor/Sub-Contractors may be responsible for the use of any radio-active material;
- e) Pressure waves caused by aircraft or other aerial devices travelling at sonic or supersonic speeds;
- f) use or occupation by the Procuring Agency of any part of the Works, except as may be specified in the Contract;
- g) late handing over of sites, anomalies in drawings, late delivery of designs and drawings of any part of the Works by the Procuring Agency 's personnel or by others for whom the Procuring Agency is responsible;
- h) a suspension under Sub-Clause 2.3 unless it is attributable to the Contractor 's failure; and

- i) physical obstructions or physical conditions other than climatic conditions, encountered on the Site during the performance of the Works, for which the Contractor immediately notified to the Procuring Agency and accepted by the Procuring Agency.

## **7. TIME FOR COMPLETION**

### **7.1 Execution of the Works**

The Contractor shall commence the Works on the Commencement Date and shall proceed expeditiously and without delay and shall complete the Works, subject to Sub-Clause 7.3 below, within the Time for Completion.

### **7.2 Programme**

Within the time stated in the Contract Data, the Contractor shall submit to the Engineer/Procuring Agency a Programme for the Works in the form stated in the Contract Data.

### **7.3 Extension of Time**

The Contractor shall, within such time as may be reasonable under the circumstances, notify the Procuring Agency/Engineer of any event(s) falling within the scope of Sub-Clause 6.1 or 10.3 of these Conditions of Contract and request the Procuring Agency/Engineer for a reasonable extension in the time for the completion of works. Subject to the aforesaid, the Procuring Agency/Engineer shall determine such reasonable extension in the time for the completion of works as may be justified in the light of the details/particulars supplied by the Contractor in connection with the such determination by the Procuring Agency/Engineer within such period as may be prescribed by the Procuring Agency/Engineer for the same; and the Procuring Agency may extend the time for completion as determined.

### **7.4 Late Completion**

If the Contractor fails to complete the Works within the Time for Completion, the Contractor 's only liability to the Procuring Agency for such failure shall be to pay the amount as **liquidity damages** stated in the Contract Data for each day for which he fails to complete the Works.

## **8. TAKING-OVER**

### **8.1 Completion**

The Contractor may notify the Engineer/Procuring Agency when he considers that the Works are complete.

## **8.2 Taking-Over Notice**

Within fourteen (14) days of the receipt of the said notice of completion from the Contractor the Procuring Agency/Engineer shall either takeover the completed works and issue a Certificate of Completion to that effect or shall notify the Contractor his reasons for not taking-over the works. While issuing the Certificate of Completion as aforesaid, the Procuring Agency/Engineer may identify any outstanding items of work which the Contractor shall undertake during the Maintenance Period.

## **9. REMEDYING DEFECTS**

### **9.1 Remediating Defects**

The Contractor shall for a period stated in the Contract Data from the date of issue of the Certificate of Completion carry out, at no cost to the Procuring Agency, repair and rectification work which is necessitated by the earlier execution of poor quality of work or use of below specifications material in the execution of Works and which is so identified by the Procuring Agency/Engineer in writing within the said period. Upon expiry of the said period, and subject to the Contractor 's faithfully performing his aforesaid obligations, the Procuring Agency/Engineer shall issue a Maintenance Certificate whereupon all obligations of the Contractor under this Contract shall come to an end.

Failure to remedy any such defects or complete outstanding work within a reasonable time shall entitle the Procuring Agency to carry out all necessary works at the Contractor 's cost. However, the cost of remedying defects not attributable to the Contractor shall be valued as a Variation.

### **9.2 Uncovering and Testing**

The Engineer/Procuring Agency may give instruction as to the uncovering and/or testing of any work. Unless as a result of an uncovering and/or testing it is established that the Contractor 's design, materials, plant or workmanship are not in accordance with the Contract, the Contractor shall be paid for such uncovering and/or testing as a Variation in accordance with Sub-Clause 10.2.

## **10. VARIATIONS AND CLAIMS**

### **10.1 Right to Vary**

The Procuring Agency/Engineer may issue Variation Order(s) in writing. Where for any reason it has not been possible for the Procuring Agency/Engineer to issue such Variations Order(s), the Contractor may confirm any verbal orders given by the Procuring Agency/Engineer in writing and if the same are not refuted/denied by the Procuring Agency/Engineer within ten (10) days of the receipt of such confirmation the same shall be deemed to be a Variation Orders for the purposes of this Sub-Clause.

## **10.2 Valuation of Variations**

Variations shall be valued as follows:

- a) at a lump sum price agreed between the Parties, or
- b) where appropriate, at rates in the Contract, or
- c) in the absence of appropriate rates, the rates in the Contract shall be used as the basis for valuation, or failing which
- d) at appropriate new rates, as may be agreed or which the Engineer/Procuring Agency considers appropriate, or
- e) if the Engineer/Procuring Agency so instructs, at day work rates set out in the Contract Data for which the Contractor shall keep records of hours of labour and Contractor 's Equipment, and of Materials, used.

## **10.3 Changes in the Quantities.**

- a) If the final quantity of the work done differs from the quantity in the Bill of Quantities for the particular item by more than 25 percent, provided the change exceeds 1 percent of the Initial Contract Price, the Procuring Agency/Engineer shall adjust the rate to allow for the change and will be valued as per sub clause 10.2.
- b) The Engineer shall not adjust rates from changes in quantities if thereby the Initial Contract Price is exceeded by more than 15 percent, except with the prior approval of the Procuring Agency.
- c) If requested by the Engineer, the contractor shall provide the Engineer with a detailed cost breakdown of any rate in the Bill of Quantities.

## **10.4 Early Warning**

The Contractor shall notify the Engineer/Procuring Agency in writing as soon as he is aware of any circumstance which may delay or disrupt the Works, or which may give rise to a claim for additional payment.

To the extent of the Contractor 's failure to notify, which results to the Engineer/Procuring Agency being unable to keep all relevant records or not taking steps to minimize any delay, disruption, or Cost, or the value of any Variation, the Contractor 's entitlement to extension of the Time for Completion or additional payment shall be reduced/rejected.

## **10.5 Valuation of Claims**

If the Contractor incurs Cost as a result of any of the Procuring Agency 's Risks, the Contractor shall be entitled to the amount of such Cost. If as a result of any

Procuring Agency 's Risk, it is necessary to change the Works, this shall be dealt with as a Variation subject to Contractor 's notification for intention of claim to the Engineer/Procuring Agency within fourteen (14) days of the occurrence of cause.

## **10.6 Variation and Claim Procedure**

The Contractor shall submit to the Engineer/Procuring Agency an itemized detailed breakdown of the value of variations and claims within twenty-eight (28) days of the instruction or of the event giving rise to the claim. The Engineer/Procuring Agency shall check and if possible agree the value. In the absence of agreement, the Procuring Agency shall determine the value.

## **11. CONTRACT PRICE AND PAYMENT**

### **11.1 (a) Terms of Payments**

The amount due to the Contractor under any Interim Payment Certificate issued by the Engineer pursuant to this Clause, or to any other terms of the Contract, shall , subject to Clause 11.3, be paid by the Procuring Agency to the Contractor within 30 days after such Interim Payment Certificate has been jointly verified by Procuring Agency and Contractor, or, in the case of the Final Certificate referred to in Sub Clause 11.5, within 60days after such Final Payment Certificate has been jointly verified by Procuring Agency and Contractor;

Provided that the Interim Payment shall be caused in thirty (30) days and Final Payment in 60 days in case of foreign funded project. In the event of the failure of the Procuring Agency to make payment within 90 days then Procuring Agency shall pay to the Contractor compensation at the 28 days' rate of KIBOR+2% per annum in local currency and LIBOR+1% for foreign currency, upon all sums unpaid from the date by which the same should have been paid.

### **(b) Valuation of the Works**

The Works shall be valued as provided for in the Contract Data, subject to Clause 10.

### **11.2 Monthly Statements**

The Contractor shall be entitled to be paid at monthly intervals:

- a) the value of the Works executed less to the cumulative amount paid previously; and
- b) value of secured advance on the materials and valuation of variations (if any).

The Contractor shall submit each month to the Engineer/Procuring Agency a statement showing the amounts to which he considers himself entitled.

### **11.3 Interim Payments**

Within a period not exceeding seven (07) days from the date of submission of a statement for interim payment by the Contractor, the Engineer shall verify the same and within a period not exceeding thirty (30/60) days from the said date of submission by the Contractor, the Procuring Agency shall pay to the Contractor the sum subject to adjustment for deduction of the advance payments and retention money.

### **11.4 Retention**

Retention money shall be paid by the Procuring Agency to the Contractor within fourteen (14) days after either the expiry of the period stated in the Contract Data, or the remedying of notified defects, or the completion of outstanding work, all as referred to in Sub-Clause 9.1, whichever is the later.

### **11.5 Final Payment**

Within twenty-one (21) days from the date of issuance of the Maintenance Certificate the Contractor shall submit a final account to the Engineer to verify and the Engineer shall verify the same within fourteen (14) days from the date of submission and forward the same to the Procuring Agency together with any documentation reasonably required to enable the Procuring Agency to ascertain the final contract value.

Within sixty (60) days from the date of receipt of the verified final account from the Engineer, the Procuring Agency shall pay to the Contractor any amount due to the Contractor. While making such payment the Procuring Agency may, for reasons to be given to the Contractor in writing, withhold any part or parts of the verified amount.

### **11.6 Currency**

Payment shall be in the currency stated in the Contract Data.

## **12. DEFAULT**

### **12.1 Defaults by Contractor**

If the Contractor abandons the Works, refuses or fails to comply with a valid instruction of the Engineer/Procuring Agency or fails to proceed expeditiously and without delay, or is, despite a written complaint, in breach of the Contract, the Procuring Agency may give notice referring to this Sub-Clause and stating the default.

If the Contractor has not taken all practicable steps to remedy the default within fourteen (14) days after receipt of the Procuring Agency 's notice, the Procuring Agency may by a second notice given within a further twenty-one (21) days, terminate the Contract. The Contractor shall then demobilize from the Site leaving behind any Contractor 's Equipment which the Procuring Agency instructs, in the second notice, to be used for the completion of the Works at the risk and cost of the Contractor.

## **12.2 Defaults by Procuring Agency**

If the Procuring Agency fails to pay in accordance with the Contract, or is, despite a written complaint, in breach of the Contract, the Contractor may give notice referring to this Sub-Clause and stating the default. If the default is not remedied within fourteen (14) days after the Procuring Agency 's receipt of this notice, the Contractor may suspend the execution of all or parts of the Works.

If the default is not remedied within twenty-eight (28) days after the Procuring Agency 's receipt of the Contractor 's notice, the Contractor may by a second notice given within a further twenty-one (21) days, terminate the Contract. The Contractor shall then demobilize from the Site.

## **12.3 Insolvency**

If a Party is declared insolvent under any applicable law, the other Party may by notice terminate the Contract immediately. The Contractor shall then demobilize from the site leaving behind, in the case of the Contractor 's insolvency, any Contractor 's Equipment which the Procuring Agency instructs in the notice is to be used for the completion of the Works.

## **12.4 Payment upon Termination**

After termination, the Contractor shall be entitled to payment of the unpaid balance of the value of the works executed and of the Materials and Plant reasonably delivered to the site, adjusted by the following:

- a) any sums to which the Contractor is entitled under Sub-Clause 10.4,
- b) any sums to which the Procuring Agency is entitled,
- c) if the Procuring Agency has terminated under Sub-Clause 12.1 or 12.3, the Procuring Agency shall be entitled to a sum equivalent to twenty percent (20%) of the value of parts of the Works not executed at the date of the termination, and
- d) if the Contractor has terminated under Sub-Clause 12.2 or 12.3, the Contractor shall be entitled to the cost of his demobilization together with a sum equivalent to ten percent (10%) of the value of parts of the works not executed at the date of termination.

The net balance due shall be paid or repaid within twenty-eight (28) days of the notice of termination.

# **13. RISKS AND RESPONSIBILITIES**

## **13.1 Contractor's Care of the Works**

Subject to Sub-Clause 9.1, the Contractor shall take full responsibility for the care

of the Works from the Commencement Date until the date of the Procuring Agency 's/Engineer 's issuance of Certificate of Completion under Sub-Clause 8.2. Responsibility shall then pass to the Procuring Agency. If any loss or damage happens to the Works during the above period, the Contractor shall rectify such loss or damage so that the Works conform with the Contract.

Unless the loss or damage happens as a result of any of the Procuring Agency 's Risks, the Contractor shall indemnify the Procuring Agency, or his agents against all claims loss, damage and expense arising out of the Works.

## **13.2 Force Majeure**

If Force Majeure occurs, the Contractor shall notify the Engineer/Procuring Agency immediately. If necessary, the Contractor may suspend the execution of the Works and, to the extent agreed with the Procuring Agency demobilize the Contractor 's Equipment.

If the event continues for a period of eighty-four (84) days, either Party may then give notice of termination which shall take effect twenty-eight (28) days after the giving of the notice.

After termination, the Contractor shall be entitled to payment of the unpaid balance of the value of the Works executed and of the Materials and Plant reasonably delivered to the Site, adjusted by the following:

- a) any sums to which the Contractor is entitled under Sub-Clause 10.4,
- b) the cost of his demobilization, and
- c) less any sums to which the Procuring Agency is entitled.

The net balance due shall be paid or repaid within thirty-five (35) days of the notice of termination.

## **14. INSURANCE**

### **14.1 Arrangements**

The Contractor shall, prior to commencing the Works, effect insurances of the types, in the amounts and naming as insured the persons stipulated in the Contract Data except for items (a) to (e) and (i) of the Procuring Agency 's Risks under Sub-Clause 6.1. The policies shall be issued by insurers and in terms approved by the Procuring Agency. The Contractor shall provide the Engineer/Procuring Agency with evidence that any required policy is in force and that the premiums have been paid.

### **14.2 Default**

If the Contractor fails to effect or keep in force any of the insurances referred to in the previous Sub-Clause, or fails to provide satisfactory evidence, policies or receipts, the Procuring Agency may, without prejudice to any other right or

remedy, effect insurance for the cover relevant to such as a default and pay the premiums due and recover the same plus a sum in percentage given in Contractor Data from any other amounts due to the Contractor.

## **15. RESOLUTION OF DISPUTES**

### **15.1 Engineer's Decision**

If a dispute of any kind whatsoever arises between the Procuring Agency and the Contractor in connection with the works, the matter in dispute shall, in the first place, be referred in writing to the Engineer, with a copy to the other party. Such reference shall state that it is made pursuant to this Clause. No later than the twenty-eight (28) days after the day on which he received such reference, the Engineer shall give notice of his decision to the Procuring Agency (Superintending Engineer) and the Contractor.

Unless the Contract has already been repudiated or terminated, the Contractor shall, in every case, continue to proceed with the work with all due diligence, and the Contractor and the Procuring Agency (Superintending Engineer) shall give effect forthwith to every such decision of the Engineer unless and until the same shall be revised, as hereinafter provided in an arbitral award.

### **15.2 Notice of Dissatisfaction**

If a Party is dissatisfied with the decision of the Engineer of consultant or if no decision is given within the time set out in Sub-Clause 15.1 here above, the Party may give notice of dissatisfaction referring to this Sub-Clause within fourteen (14) days of receipt of the decision or the expiry of the time for the decision. If no notice of dissatisfaction is given within the specified time, the decision shall be final and binding on the Parties. If notice of dissatisfaction is given within the specified time, the decision shall be binding on the Parties who shall give effect to it without delay unless and until the decision of the Engineer is revised by an arbitrator.

If a contractor is dissatisfied with the decision of the Engineer of the department or decision is not given in time then he can approach Superintending Engineer within 14 days, in case of dissatisfaction with decision of Superintending Engineer or not decided within 28 days, then arbitration process would be adopted as per clause 15.3.

### **15.3 Arbitration**

A dispute which has been the subject of a notice of dissatisfaction shall be finally settled as per provisions of Arbitration Act 1940 (Act No. X of 1940) and Rules made there under and any statutory modifications thereto. Any hearing shall be held at the place specified in the Contract Data and in the language referred to in Sub-Clause 1.5.

## 16 INTEGRITY PACT

16.1 If the Contractor or any of his Sub-Contractors, agents or servants is found to have violated or involved in violation of the Integrity Pact signed by the Contractor as Schedule-F to his Bid, then the Procuring Agency shall be entitled to:

- (a) recover from the Contractor an amount equivalent to ten times the sum of any commission, gratification, bribe, finder 's fee or kickback given by the Contractor or any of his Sub-Contractors, agents or servants;
- (b) terminate the Contract; and
- (c) recover from the Contractor any loss or damage to the Procuring Agency as a result of such termination or of any other corrupt business practices of the Contractor or any of his Sub-Contractors, agents or servants.

On termination of the Contract under Sub-Para (b) of this Sub-Clause, the Contractor shall demobilize from the site leaving behind Contractor 's Equipment which the Procuring Agency instructs, in the termination notice, to be used for the completion of the works at the risk and cost of the Contractor. Payment upon such termination shall be made under Sub-Clause 12.4, in accordance with Sub-Para (c) thereof, after having deducted the amounts due to the Procuring Agency under Sub-Para (a) and (c) of this Sub-Clause.

**STANDARD FORMS**

**BID SECURITY  
PERFORMANCE SECURITY  
CONTRACT AGREEMENT  
MOBILIZATION ADVANCE GUARANTEE  
INDENTURE BOND FOR SECURED ADVANCE**

**BID SECURITY**  
**(Bank Guarantee)**

Security Executed on \_\_\_\_\_  
(Date)

Name of Surety (Bank) with Address: \_\_\_\_\_  
(Scheduled Bank in Pakistan)

Name of Principal (Bidder) with Address \_\_\_\_\_

Penal Sum of Security Rupees. \_\_\_\_\_ (Rs. \_\_\_\_\_)

Bid Reference No. \_\_\_\_\_

KNOW ALL MEN BY THESE PRESENTS, that in pursuance of the terms of the bid and at the request of the said Principal (Bidder) we, the Surety above named, are held and firmly bound unto \_\_\_\_\_

(hereinafter called the 'Procuring Agency') in the sum stated above for the payment of which sum well and truly to be made, we bind ourselves, our heirs, executors, administrators and successors, jointly and severally, firmly by these presents.

THE CONDITION OF THIS OBLIGATION IS SUCH, that whereas the Bidder has submitted the accompanying bid dated \_\_\_\_\_ for Bid No. \_\_\_\_\_ for \_\_\_\_\_ (Particulars of Bid) to the said Procuring Agency; and

WHEREAS, the Procuring Agency has required as a condition for considering said bid that the **bidder** furnishes a bid security in the above said sum from a Scheduled Bank in Pakistan or from a foreign bank duly counter-guaranteed by a Scheduled Bank in Pakistan, to the procuring agency, conditioned as under:

- (1) that the bid security shall remain in force up to and including the date 28 days after the deadline for validity of bids as stated in the Instructions to bidders or as it may be extended by the procuring agency, notice of which extension(s) to the Surety is hereby waived;
- (2) that the bid security of unsuccessful bidders will be returned by the procuring agency after expiry of its validity or upon signing of the Contract Agreement; and
- (3) that in the event of failure of the successful bidder to execute the proposed Contract Agreement for such work and furnish the required Performance Security, the entire said sum be paid immediately to the said procuring agency pursuant to Clause 15.6 of the Instruction to bidders for the successful bidder's failure to perform.

NOW THEREFORE, if the successful bidder shall, within the period specified therefore, on the prescribed form presented to him for signature enter into a formal Contract with the said procuring agency in accordance with his bid as accepted and furnish within twenty eight (28) days of his being requested to do so, a Performance Security with good and sufficient surety, as may be required, upon the form prescribed by the said procuring agency for the faithful performance and proper fulfilment of the said Contract or in the event of non-withdrawal of the said bid within the time specified for its validity then this obligation shall be void and of no effect, but otherwise to remain in full force and effect.

PROVIDED THAT the Surety shall forthwith pay the procuring agency, the said sum upon first written demand of the procuring agency (without cavil or argument) and without requiring the procuring agency to prove or to show grounds or reasons for such demand,

notice of which shall be sent by the procuring agency by registered post duly addressed to the Surety at its address given above.

PROVIDED ALSO THAT the procuring agency shall be the sole and final judge for deciding whether the Principal (Bidder) has duly performed his obligations to sign the Contract Agreement and to furnish the requisite Performance Security within the time stated above, or has defaulted in fulfilling said requirements and the Surety shall pay without objection the said sum upon demand from the procuring agency forthwith and without any reference to the Principal (Bidder) or any other person.

IN WITNESS WHEREOF, the above bounden Surety has executed the instrument under its seal on the date indicated above, the name and seal of the Surety being hereto affixed and these presents duly signed by its undersigned representative pursuant to authority of its governing body.

SURETY (Bank)

WITNESS:

Signature \_\_\_\_\_

1. \_\_\_\_\_

Name \_\_\_\_\_

\_\_\_\_\_

Title \_\_\_\_\_

Corporate Secretary (Seal)

Corporate Guarantor (Seal)

2. \_\_\_\_\_

\_\_\_\_\_  
Name, Title & Address

**FORM OF PERFORMANCE SECURITY**  
**(Bank Guarantee)**

Guarantee No. \_\_\_\_\_  
Executed on \_\_\_\_\_  
Expiry date \_\_\_\_\_

[Letter by the Guarantor to the Procuring Agency]

Name of Guarantor (Bank) with address: \_\_\_\_\_  
(Scheduled Bank in Pakistan)

Name of Principal (Contractor) with address: \_\_\_\_\_

Penal Sum of Security (express in words and figures) \_\_\_\_\_

Letter of Acceptance No. \_\_\_\_\_ Dated \_\_\_\_\_

KNOW ALL MEN BY THESE PRESENTS, that in pursuance of the terms of the bidding documents and above said Letter of Acceptance (hereinafter called the Documents) and at the request of the said Principal we, the Guarantor above named, are held and firmly bound unto the \_\_\_\_\_ (hereinafter called the procuring agency) in the penal sum of the amount stated above for the payment of which sum well and truly to be made to the said procuring agency, we bind ourselves, our heirs, executors, administrators and successors, jointly and severally, firmly by these presents.

THE CONDITION OF THIS OBLIGATION IS SUCH, that whereas the Principal has accepted the procuring agency's above said Letter of Acceptance for \_\_\_\_\_ (Name of Contract) for the \_\_\_\_\_ (Name of Project).

NOW THEREFORE, if the Principal (Contractor) shall well and truly perform and fulfill all the undertakings, covenants, terms and conditions of the said Documents during the original terms of the said Documents and any extensions thereof that may be granted by the procuring agency, with or without notice to the Guarantor, which notice is, hereby, waived and shall also well and truly perform and fulfill all the undertakings, covenants terms and conditions of the Contract and of any and all modifications of said Documents that may hereafter be made, notice of which modifications to the Guarantor being hereby waived, then, this obligation to be void; otherwise to remain in full force and virtue till all requirements of Clause 49, Defects Liability, of Conditions of Contract are fulfilled.

Our total liability under this Guarantee is limited to the sum stated above and it is a condition of any liability attaching to us under this Guarantee that the claim for payment in writing shall be received by us within the validity period of this Guarantee, failing which we shall be discharged of our liability, if any, under this Guarantee.

We, \_\_\_\_\_ (the Guarantor), waiving all objections and defenses under the Contract, do hereby irrevocably and independently guarantee to pay to the procuring agency without delay upon the procuring agency's first written demand without

cavil or arguments and without requiring the procuring agency to prove or to show grounds or reasons for such demand any sum or sums up to the amount stated above, against the procuring agency's written declaration that the Principal has refused or failed to perform the obligations under the Contract which payment will be effected by the Guarantor to Procuring Agency's designated Bank & Account Number.

PROVIDED ALSO THAT the procuring agency shall be the sole and final judge for deciding whether the Principal (Contractor) has duly performed his obligations under the Contract or has defaulted in fulfilling said obligations and the Guarantor shall pay without objection any sum or sums up to the amount stated above upon first written demand from the procuring agency forthwith and without any reference to the Principal or any other person.

IN WITNESS WHEREOF, the above-bounden Guarantor has executed this Instrument under its seal on the date indicated above, the name and corporate seal of the Guarantor being hereto affixed and these presents duly signed by its undersigned representative, pursuant to authority of its governing body.

	_____ Guarantor (Bank)
Witness:	
1. _____	Signature _____
	Name _____
_____	Title _____
Corporate Secretary (Seal)	
2. _____	
_____	_____
Name, Title & Address	Corporate Guarantor (Seal)

**FORM OF CONTRACT AGREEMENT**

THIS CONTRACT AGREEMENT (hereinafter called the "Agreement") made on the \_\_\_\_\_ day of \_\_\_\_\_ (month) 20\_\_\_\_ between \_\_\_\_\_ (hereafter called the "Procuring Agency") of the one part and \_\_\_\_\_ (hereafter called the "Contractor") of the other part.

WHEREAS the Procuring Agency is desirous that certain works, viz \_\_\_\_\_ should be executed by the Contractor and has accepted a bid by the Contractor for the execution and completion of such works and the remedying of any defects therein.

NOW this Agreement witnesseth-- as follows:

1. In this Agreement words and expressions shall have the same meanings as are respectively assigned to them in the Conditions of Contract hereinafter referred to.
2. The following documents after incorporating addenda, if any, except those parts relating to Instructions to bidders shall be deemed to form and be read and construed as part of this Agreement, viz:
  - (a) The Contract Agreement;
  - (b) The Letter of Acceptance;
  - (c) The completed Form of Bid;
  - (d) Special Stipulations (Appendix-A to Bid);
  - (e) The Special Conditions of Contract – Part II;
  - (f) The General Conditions – Part I;
  - (g) The priced Bill of Quantities (Appendix-D to Bid);
  - (h) The completed Appendices to Bid (B, C, E to L);
  - (i) The Drawings;
  - (j) The Specifications.
  - (k) \_\_\_\_\_ (any other)
3. In consideration of the payments to be made by the procuring agency to the Contractor as hereinafter mentioned, the Contractor hereby covenants with the procuring agency to execute and complete the works and remedy defects therein in conformity and in all respects with the provisions of the contract.
4. Procuring agency hereby covenants to pay the contractor, in consideration of the execution and completion of the works as per provisions of the contract, the contract Price or such other sum as may become payable under the provisions of the contract at the times and in the manner prescribed by the contract.

IN WITNESS WHEREOF the parties hereto have caused this Agreement to be executed on the day, month and year first before written in accordance with their respective laws.

Signature of the Contactor

Signature of Procuring Agency

\_\_\_\_\_  
(Seal)

\_\_\_\_\_  
(Seal)

Signed, Sealed and Delivered in the presence of:

Witness:

Witness:

\_\_\_\_\_

\_\_\_\_\_

(Name, Title and Address)

(Name, Title and Address)

## MOBILIZATION ADVANCE GUARANTEE

Bank Guarantee No. \_\_\_\_\_ Date \_\_\_\_\_

WHEREAS \_\_\_\_\_ (hereinafter called the 'Procuring Agency') has entered into a Contract for \_\_\_\_\_

(Particulars of Contract)

with \_\_\_\_\_ (hereinafter called the "Contractor").

AND WHEREAS, the Procuring Agency has agreed to advance to the Contractor, at the Contractor's request, an amount of Rupees \_\_\_\_\_ (Rs \_\_\_\_\_) which amount shall be advanced to the Contractor as per provisions of the Contract.

AND WHEREAS, the Procuring Agency has asked the Contractor to furnish Guarantee to secure the mobilization advance for the performance of his obligations under the said Contract.

AND WHEREAS, \_\_\_\_\_

(Scheduled Bank in Pakistan)

(hereinafter called the "Guarantor") at the request of the Contractor and in consideration of the **procuring agency** agreeing to make the above advance to the Contractor, has agreed to furnish the said Guarantee.

NOW, THEREFORE, the Guarantor hereby guarantees that the Contractor shall use the advance for the purpose of above mentioned Contract and if he fails and commits default in fulfilment of any of his obligations for which the advance payment is made, the Guarantor shall be liable to the procuring agency for payment not exceeding the aforementioned amount.

Notice in writing of any default, of which the procuring agency shall be the sole and final judge, on the part of the Contractor, shall be given by the procuring agency to the Guarantor, and on such first written demand, payment shall be made by the Guarantor of all sums then due under this Guarantee without any reference to the Contractor and without any objection.

This Guarantee shall remain in force until the advance is fully adjusted against payments from the Interim Payment Certificates of the Contractor or until \_\_\_\_\_ whichever is earlier.

(Date)

The Guarantor's liability under this Guarantee shall not in any case exceed the sum of Rupees \_\_\_\_\_ (Rs \_\_\_\_\_).

This Guarantee shall remain valid up to the aforesaid date and shall be null and void after the aforesaid date or earlier if the advance made to the Contractor is fully adjusted against payments from Interim Payment Certificates of the Contractor provided that the Guarantor agrees that the aforesaid period of validity shall be deemed to be extended if on the above mentioned date the advance payment is not fully adjusted.

GUARANTOR

- 1. Signature \_\_\_\_\_
- 2. Name \_\_\_\_\_
- 3. Title \_\_\_\_\_

WITNESS

1. \_\_\_\_\_  
Corporate Secretary (Seal)

2. \_\_\_\_\_  
(Name Title & Address)

\_\_\_\_\_  
Corporate Guarantor (Seal)

**INDENTURE FOR SECURED ADVANCES.**

(For use in cases in which is contract is for finished work and the contractor has entered into an agreement for the execution of a certain specified quantity of work in a given time).

This INDENTURE made the ..... day of .....  
..... 20..... BETWEEN (hereinafter called "the Contractor" which expression shall where the context so admits or implied be deemed to include his heirs, executors, administrators and assigns) of the one part and THE GOVERNOR OF SINDH (hereinafter called "the Government" of the other part).

WHEREAS by an agreement, dated (hereinafter called the said agreement, the contractor has agreed to perform the under-mentioned works (hereinafter referred to as the said work):-

(Here enter (the description of the works).<sup>1</sup>

AND WHEREAS the contractor has applied to the .....  
.....for an advance to him of Rupees .....  
(Rs. ....) on the security of materials absolutely belonging to him and brought by him to the site of the said works the subject of the said agreement for use in the construction of such of the said works as he has undertaken to execute at rates fixed for the finished work (inclusive of the cost of materials and labour and other charge) AND WHEREAS the Government has agreed to advance to the Contractor the sum of Rupees, (Rs. ....) on the security of materials the quantities and other particulars of which are detailed in Part II of Running Account Bill (B). the said works signed by the contractor

Fin R.Form.17.A

On ..... and on such covenants and conditions as are hereinafter contained and the Government has reserved to itself the option of marking any further advance or advances on the security of other materials brought by the Contractor to the site of the said works.

NOW THIS INDENTURE WTTNESSETH that in pursuance of the said agreement and in consideration of the sum of Rupees.....  
(Rs. ....) on or before the execution of these presents paid to the Contractor by the Government (the receipt whereof the Contractor doth hereby acknowledge) and of such further advances (if any) as may be made to him as aforesaid (all of which advances are hereinafter collectively referred to as the said amount) the Contractor doth hereby assign unto the Government the said materials by way of security for the said amount

And doth hereby covenant and agree with the Government and declare ay follow :-

- (1) That the said sum of Rupees ..... RS. .... ) so advanced by the Government to the Contractor as aforesaid and all or any further sum or sums which may be advanced as aforesaid shall be employed by the contractor in or towards expending the execution of the said works and for no other purpose whatsoever.
- (2) That the materials detailed in the said Running Account Bill (B) which have been offered to and accepted by (he Government as security for the said amount are

absolutely by the Contractors own property free from encumbrances of any kind and the Contractor will not make any application for or receive a further advance on the security of materials which are not absolutely his own property and free from encumbrances of any kind and the contractor hereby agrees, at all times, to indemnify and save harmless the Government against all claims whatsoever to any materials in respect of which an advance has been made to him as aforesaid.

(3) That the said materials detailed in the said Running Account Bill (B) and all other materials on the security of which any further advance or advances may hereafter be made as aforesaid (hereinafter called the said materials) shall be used by the Contractor solely in *the* execution of the said works in accordance with the directions of the Divisional Officer (hereinafter called the Divisional Officer) and in the terms of the said agreement.

(4) That the Contractor shall make at his own cost all necessary and adequate arrangement for the proper watch, safe custody and protection against all risks of the said material and that until used in construction as aforesaid the said materials shall remain at the site of the said works in the Contractor's custody and at his own risk and on his own responsibility and shall at all times be open to inspection by (he Divisional Officer or any officer authorized by him. In the event of the said materials of any part (hereof being stolen, destroyed or damaged or becoming deteriorated in a greater degree than is due to reasonable use and wear thereof Contractor will forthwith replace the same with other materials of like quality or repair and make good the same as required by the Divisional Officer and the materials so brought to replace the said materials so repaired and made good shall also be considered as security for the said amount.

(5) 'Hurt the said materials shall not on any account be removed from the site of the said works except with the written permission of the Divisional Officer or an officer authorized by him in that behalf

(6) That the said amount shall be payable in full when or before the Contractor receives payment, from the Government of the price payable to him for the said works under the terms and provisions of the said agreement PROVIDED THAT if any intermediate payments are made to the contractor on account of work done then on the occasion of each such payment the Government will be at liberty to make a recovery from the Contractors Bill for such payment by deducting there from in the value of the said materials (hen actually used in the construction and in respect of which recovery has not been made previously the value for this purpose being determined in respect of each description of material at (he rates at which the amount of the advances made under these presents were calculated.

(7) at if the Contractor shall at any time make any default in the performance or observation in any respect of any of the terms and provisions of the said agreement or of these presents the total amount of the advance or advances that may still be owing to the Government shall immediately on the happening of such default be repayable by the Contractor to the Government together with interest thereon at twelve percent per annum from the date or respective dates of such advance or advances to the date or repayment and with all costs, charges, damages and expenses incurred by the Government in or for the recovery thereof or the enforcement of this security or otherwise by reason of (he default of the Contractor and any moneys so becoming due and payable shall constitute a debt due from the Contractor to the Government and the Contractor hereby covenants and agrees with the Government to repay and the same respectively to it accordingly.

(8) That the Contractor hereby charges all the said materials with the repayment to the Government of the said sum of Rupees.....

(Rs. .... ) and any further sum or sums which may be advanced as aforesaid and all costs charges damages and expenses payable under these present PROVIDED ALWAYS and it is hereby agreed and declared that not, withstanding anything in the said agreement and without prejudice to the powers contained therein if and whether the covenant for payment and repayment hereinbefore contained shall become enforceable and the money owing shall not be paid to accordingly.

Once there with the Government may at any time thereafter adopt all or any of following courses as it may deem best :-

- (a) Seize and utilize the said materials or any part thereof in the completion of the said works on behalf of the Contractor in accordance with the provisions in that behalf contained in the said agreement debiting the Contractor with the actual cost of effecting such completion the amount due in respect of advances under these presents and crediting the Contractor with the value of work done as he had carried it out in accordance with the said agreement and at the rates thereby provided. If the balance is against the Contractor he is to pay the same to the Government on demand.
- (b) Remove and sell by public auction the seized materials or any part thereof and out of the moneys arising from the sale retain all the sums aforesaid repayable to the Government under these presents and pay over the surplus (if any) to the Contractor.
- (c) Deduct all or any part of the moneys owing out of the security deposit or any sum due to the Contractor under the said agreement.

(9) That except as is expressly provided by the presents interest on the said advance shall not be payable.

(10) That in the event of any conflict between the provisions of these presents and the said agreement the provisions of these presents shall prevail and in the event of any dispute or difference arising over the construction or effect of these presents the settlement of which has not been hereinbefore expressly provided for the same shall be referred to the Superintending Engineer/Executive District Officer/Officer one grade higher to officer signed the agreement Circle whose.....decision shall be final and the provisions of the Arbitration Act 1940 for the time being in force so far as they are applicable shall apply to any such reference.

Singed, sealed and delivered by\*

In the presence of



1<sup>st</sup> witness  
2<sup>nd</sup> witness

Signed, sealed and delivered by\*

In the presence of



1<sup>st</sup> witness  
2<sup>nd</sup> witness

## **SPECIFICATION**

**CONSTRUCTION OF 03 CLASSROOMED PRIMARY SCHOOL INCLUDING LAVATORY BLOCK, COMPOUND WALL INCLUDING MAIN GATE, EXTERNAL DEVELOPMENT, WATER SUPPLY & SANITARY WORK & ELECTRIFICATION WORKS (FOLLOW THE ATTACHED DRAWINGS)**

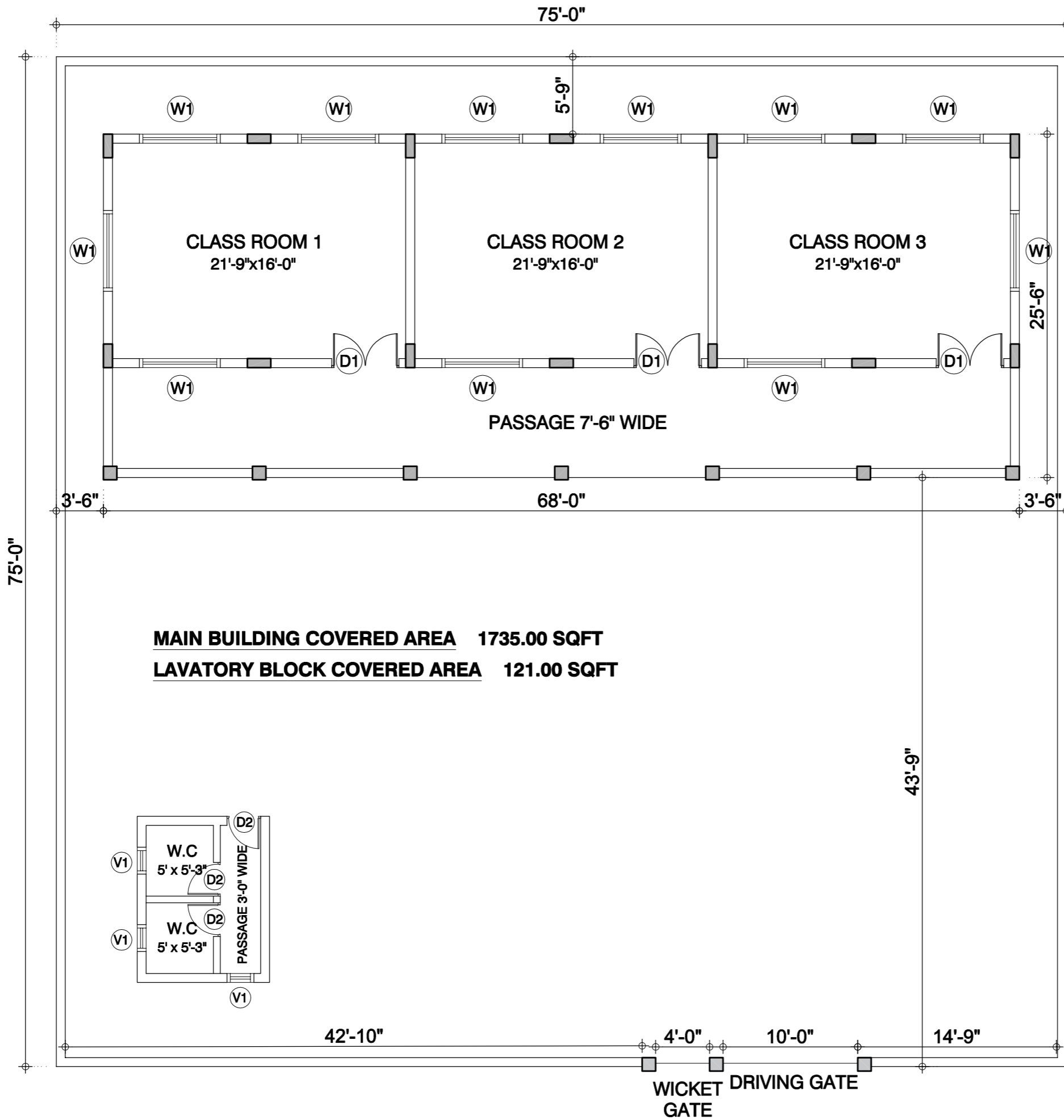

**QAMAR & ASSOCIATES**  
CONSULTING ENGINEERS, ARCHITECTS,  
INTERIOR DESIGNERS & PLANNERS  
OFFICE NO.E-47, GLASS TOWER, NEAR TEEN TALWAR,  
CLIFTON, KARACHI, PH. # 092-21-35639878,  
FAX: # 092-21-35639879 KARACHI.

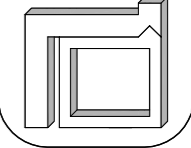

DESIGNED BY:	REV.
M.FAREED QURESHI	
ENGR.QAMAR JAWAID	
ENGR.QAMAR JAWAID	
SCALE: N.T.S	
DATE:	

**PROJECT TITLE:**  
03 CLASS ROOMS BUILDING FOR PRIMARY SCHOOL

**BUILDING TYPE:**  
MASTER PLAN

**SHEET REFERENCE NUMBER**  
**AR-01**  
SHEET\_OF\_

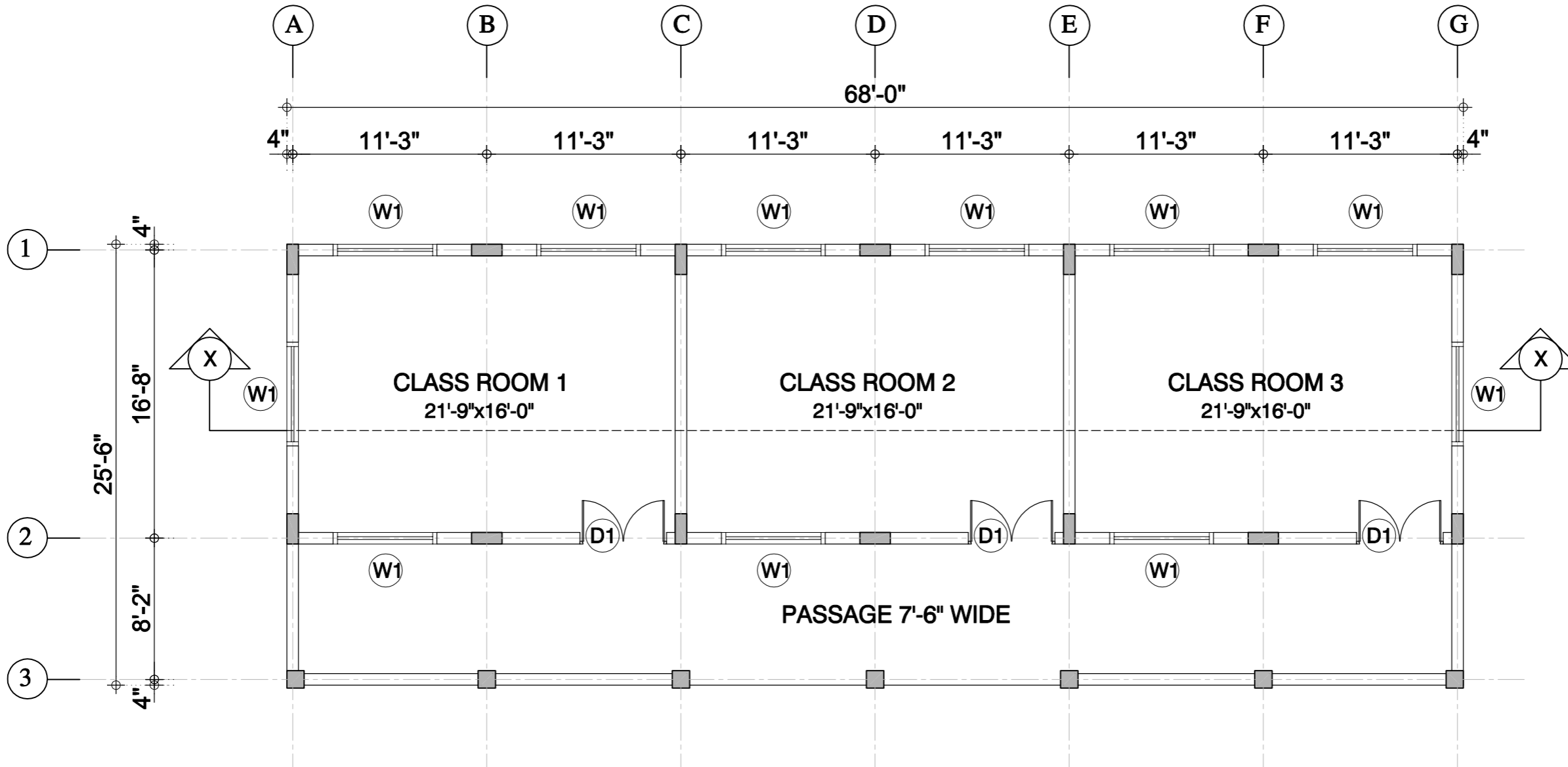

**GROUND FLOOR PLAN**

**MAIN BUILDING COVERED AREA 1735.00 SQFT**  
**LAVATORY BLOCK COVERED AREA 121.00 SQFT**

SCHEDULE OF DOORS&WINDOWS		
TYPE	SIZE	S.LEV
D1	5'-0"X8'-0"	0'-0"
D2	2'-6"X7'-0"	0'-0"
W1	6'-0"X5'-0"	3'-0"
V1	2'-0"X3'-0"	5'-0"

**QAMAR & ASSOCIATES**  
 CONSULTING ENGINEERS, ARCHITECTS,  
 INTERIOR DESIGNERS & PLANNERS  
 OFFICE NO.E-47, GLASS TOWER, NEAR TEEN TALWAR,  
 CLIFTON, KARACHI, PH. # 092-21-35639878,  
 FAX. # 092-21-35639879 KARACHI.

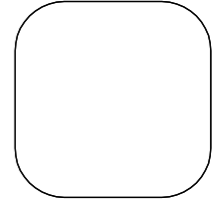

DESIGNED BY:	REV.
M.FAREED QURESHI	
ENGR.QAMAR JAWAID	
ENGR.QAMAR JAWAID	
SCALE: N.T.S	
DATE:	

**PROJECT TITLE:**  
 03 CLASS ROOMS BUILDING FOR PRIMARY SCHOOL

**BUILDING TYPE:**  
 GROUND FLOOR PLAN

**SHEET REFERENCE NUMBER**  
**AR-02**  
 SHEET\_OF\_

LEV. + 15'-6"  
PARAPET LVL.

ROOF LVL.  
LEV. + 13'-6"

LEV. + 2'-0"  
PLINTH LVL.

GROUND LVL.

LEV. ± 0'-0"

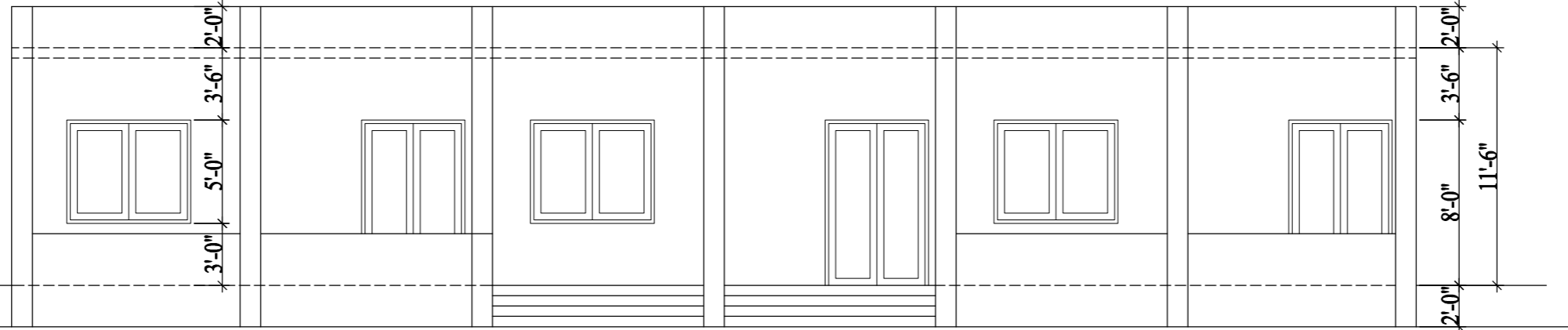

**FRONT ELEVATION**

LEV. + 15'-6"  
PARAPET LVL.

ROOF LVL.  
LEV. + 13'-6"

LEV. + 2'-0"  
PLINTH LVL.

GROUND LVL.

LEV. ± 0'-0"

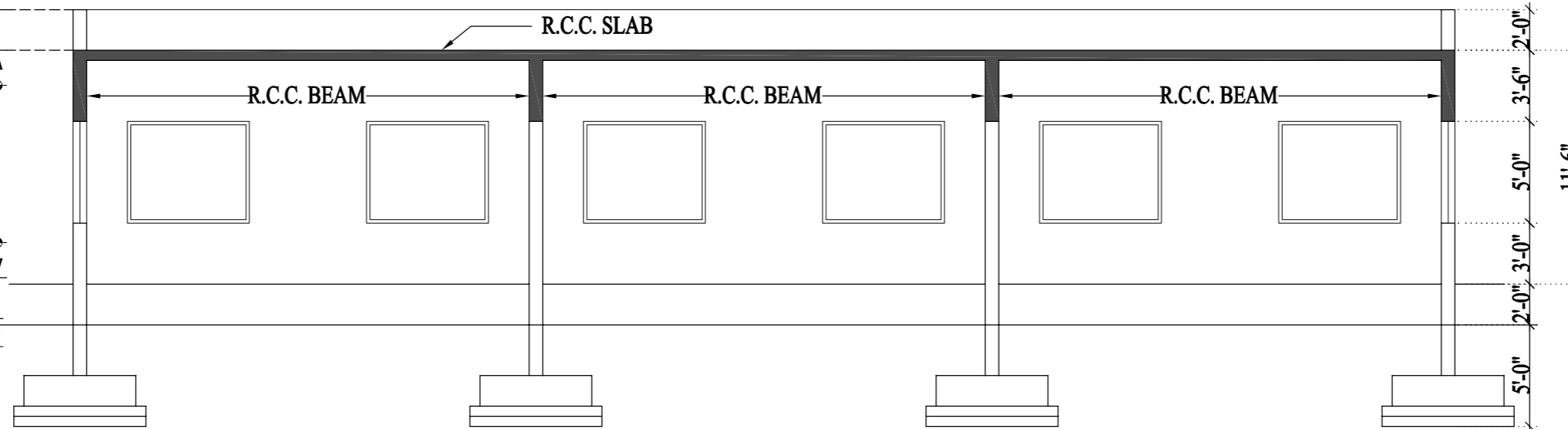

**SECTION AT X-X**

**SCHEDULE OF DOORS&WINDOWS**

TYPE	SIZE	S.LEV
D1	5'-0"X8'-0"	0'-0"
D2	2'-6"X7'-0"	0'-0"
W1	6'-0"X5'-0"	3'-0"
V1	2'-0"X3'-0"	5'-0"

**QAMAR & ASSOCIATES**

CONSULTING ENGINEERS, ARCHITECTS,  
INTERIOR DESIGNERS & PLANNERS  
OFFICE NO.E-47, GLASS TOWER, NEAR TEEN TALWAR,  
CLIFTON, KARACHI, PH. # 092-21-35639878,  
FAX. # 092-21-35639879 KARACHI.

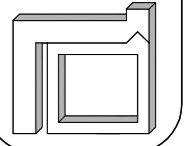

REV.

DESIGNED BY:	REV.
M.FAREED QURESHI	
ENGR.QAMAR JAWAID	
ENGR.QAMAR JAWAID	
SCALE:	N.T.S
DATE:	

PROJECT TITLE:

03 CLASS ROOMS BUILDING FOR PRIMARY SCHOOL

BUILDING TYPE:  
FRONT ELEVATION & SECTION AT X-X

SHEET REFERENCE NUMBER

**AR-03**  
SHEET OF \_

## GENERAL NOTES:-

- 1 STRUCTURAL DRAWINGS TO BE READ IN CONJUNCTION OF APPROVED ARCHITECTURAL DRAWINGS.
- 2 ALL DIMENSIONS PERTAINING TO EXISTING CONSTRUCTION OR SITE CONDITION MUST BE FIELD VERIFIED AND APPROVAL OF CONSULTANT OBTAINED BEFORE STARTING OF WORK.
- 3 CONCRETE USED IN ALL R.C.C WORKS SHOULD BE OF  $f_c'=3200$  PSI(CYLINDER)
- 4 EXCEPT IN COLUMNS,FOUNDATION,SHEAR AND RETAINING WALL SHOULD BE OF  $f_c'=4000$ PSI(CYLINDER)
- 5 H.T. STANDS FOR HIGH TENSILE DEFORMED BARS-BILLET STEEL, HAVING MINIMUM YIELD STRESS OF 60KSI.(414 N/MM), AND SHOULD COMPLY WITH THE REQUIREMENTS OF B.S.446IFOR DEFORMED COLD WORKED STEEL BARS.
- 6 M.S. STANDS FOR PLAIN MILD STEEL BARS, HAVING MINIMUM YIELD STRESS OF 36 ksi. (248 N/MM) AND SHOULD COMPLY WITH THE REQUIREMENTS OF B.S. 4448 FOR PLAIN MILD STEEL BARS.
- 7 FOLLOWING MINIMUM CONCRETE COVERS TO BE PROVIDED TO REINFORCING BARS.
 

A - FOUNDATIONS	.....	2.5" (62.5 MM)
B - COLUMNS	.....	1.5" (37 MM)
C - BEAMS	.....	1.5" (37 MM)
D - SLAB	.....	3/4" (20 MM)
E - WALL	.....	3/4" (20 MM)
- 8 ALL R.C.C. WORKS TO BE MACHINE MIXED AND WELL VIBRATED TO HAVE CONCRETE COMPLETELY FREE FROM HONEY COMBING.
- 9 STEEL CHAIRS (AT LEAST 1/2"Ø M.S.) TO BE PROVIDED TO HOLD TOP BARS OF SLAB OR WHERE EVER REQUIRED IN POSITION.
- 10 SLAB AND BEAMS TO BE CASTED MONOLITHICALLY.
- 11 BARS TO BE LAPPED AS SHOWN ON DRAWINGS, MINIMUM LENGTH IS 48 Ø OF BAR OR 12" WHICHEVER IS GREATER.
- 12 TOP DISTRIBUTION REINFORCEMENT IF NOT SHOWN ON DRAWINGS, WILL BE 3/8" D H.T.10"C/C.
- 13 COARSE AGGREGATE
  - A - FOR NON STRUCTURAL PLAIN CEMENT CONCRETE, SHINGLE OR GRAVEL OF NOMINAL MAXIMUM SIZE 3/4" (20 MM) TO BE USED.
- 14 WATER
  - A - WATER USED IN MIXING CONCRETE SHALL BE CLEAN AND FREE FROM INJURIOUS AMOUNTS OF OIL, ACIDS, ALKALIS, SALT OR ORGANIC SUBSTANCES.
- 15 CONSTRUCTION JOINTS NOT SHOWN ON THE DRAWINGS SHALL NEED PRIOR APPROVAL OF THE ENGINEER IN GENERAL, THEY SHOULD BE LOCATED WITHIN THE MIDDLE THIRD OF SPANS OF SLAB, BEAMS AND GIRDERS.  
JOINTS IN THE GIRDERS SHOULD BE OFFSET A MINIMUM DISTANCE OF TWICE THE WIDTH OF THE INTERSECTING BEAMS.  
JOINTS IN WALL AND COLUMNS SHOULD BE AT THE UNDER SIDE OF FLOORS, SLABS, DROP PANELS, CAPITALS HAUNCHES, BEAMS OR GIRDERS AND AT THE TOP OF THE FOOTING OR FLOOR SLABS.
- 16 JOINTS IN WALL AND COLUMNS SHOULD BE AT THE UNDER SIDE OF FLOORS, SLABS,
- 17 PROJECT IS DESIGN FOR BEARING CAPACITY OF SOIL AT LEVEL OF 5'-0" IS 1.10 TSF.
- 18 USE STEEL OF GRADE-60 IN ALL R.C.C WORK EXCEPT RINGS, HAVING MINIMUM YIELD STRENGTH OF 60 KSI.

SHEET  
REFERNACE  
NUMBER  
  
**GN-01**  
SHEET\_OF\_

PROJECT TITLE:  
  
03 CLASS ROOMS BUILDING FOR PRIMARY  
SCHOOL  
  
BUILDING TYPE:  
GENERAL NOTES

DESIGNED BY:	REV.
DRAWN BY: M.FAREED QURESHI	
CKD BY: ENGR.QAMAR JAWAID	
APR BY: ENGR.QAMAR JAWAID	
SCALE: N.T.S	
DATE: -	

**QAMAR & ASSOCIATES**  
CONSULTING ENGINEERS, ARCHITECTS,  
INTERIOR DESIGNERS & PLANNERS  
OFFICE NO.E-47, GLASS TOWER, NEAR TEEN TALWAR,  
CLIFTON, KARACHI, PH. # 092-21-35639878,  
FAX. # 092-21-35639879 KARACHI.

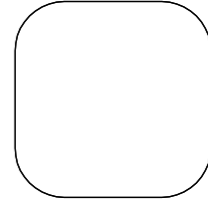
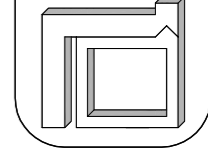

DESIGNED BY:	REV.
M.FAREED QURESHI	
ENGR.QAMAR JAWAID	
ENGR.QAMAR JAWAID	
SCALE:	N.T.S
DATE:	

PROJECT TITLE:  
 03 CLASS ROOMS BUILDING FOR PRIMARY SCHOOL  
 BUILDING TYPE:  
 COLUMN LAYOUT PLAN

SHEET REFERENCE NUMBER  
**S-01**  
 SHEET\_OF\_

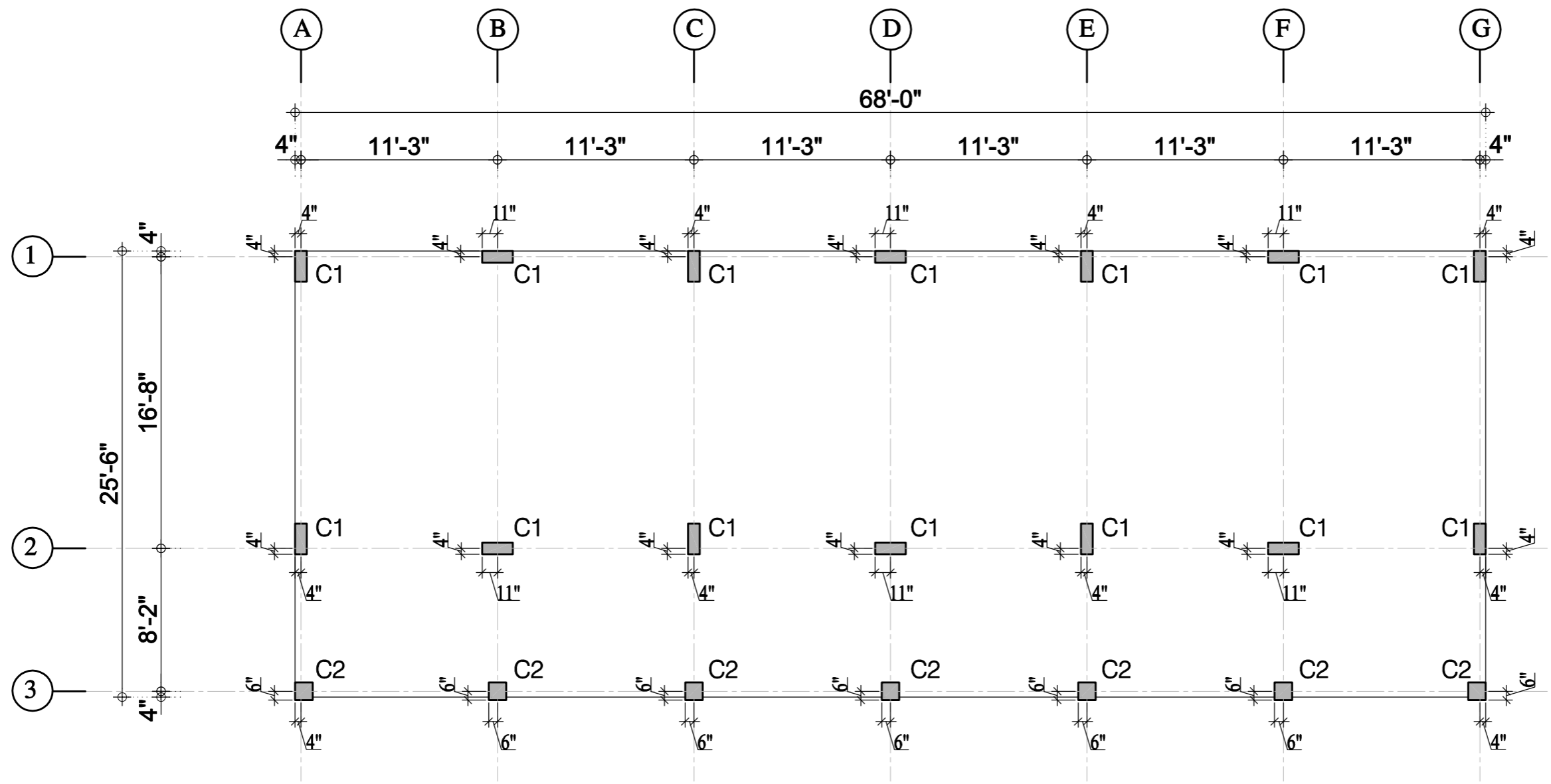

**COLUMN LAYOUT PLAN**

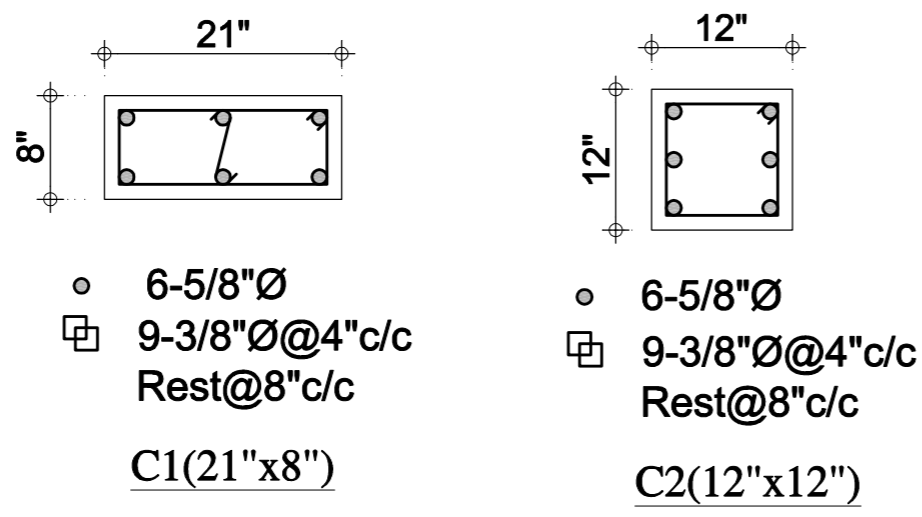

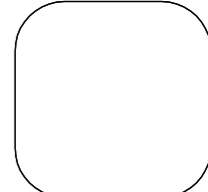
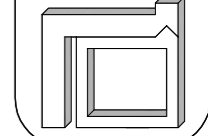

DESIGNED BY:	REV.
M.FAREED QURESHI	
ENGR.QAMAR JAWAID	
ENGR.QAMAR JAWAID	
SCALE:	N.T.S
DATE:	

PROJECT TITLE:  
 03 CLASS ROOMS BUILDING FOR PRIMARY SCHOOL  
 BUILDING TYPE:  
 FOUNDATION LAYOUT PLAN

SHEET REFERENCE NUMBER  
**S-02**  
 SHEET OF

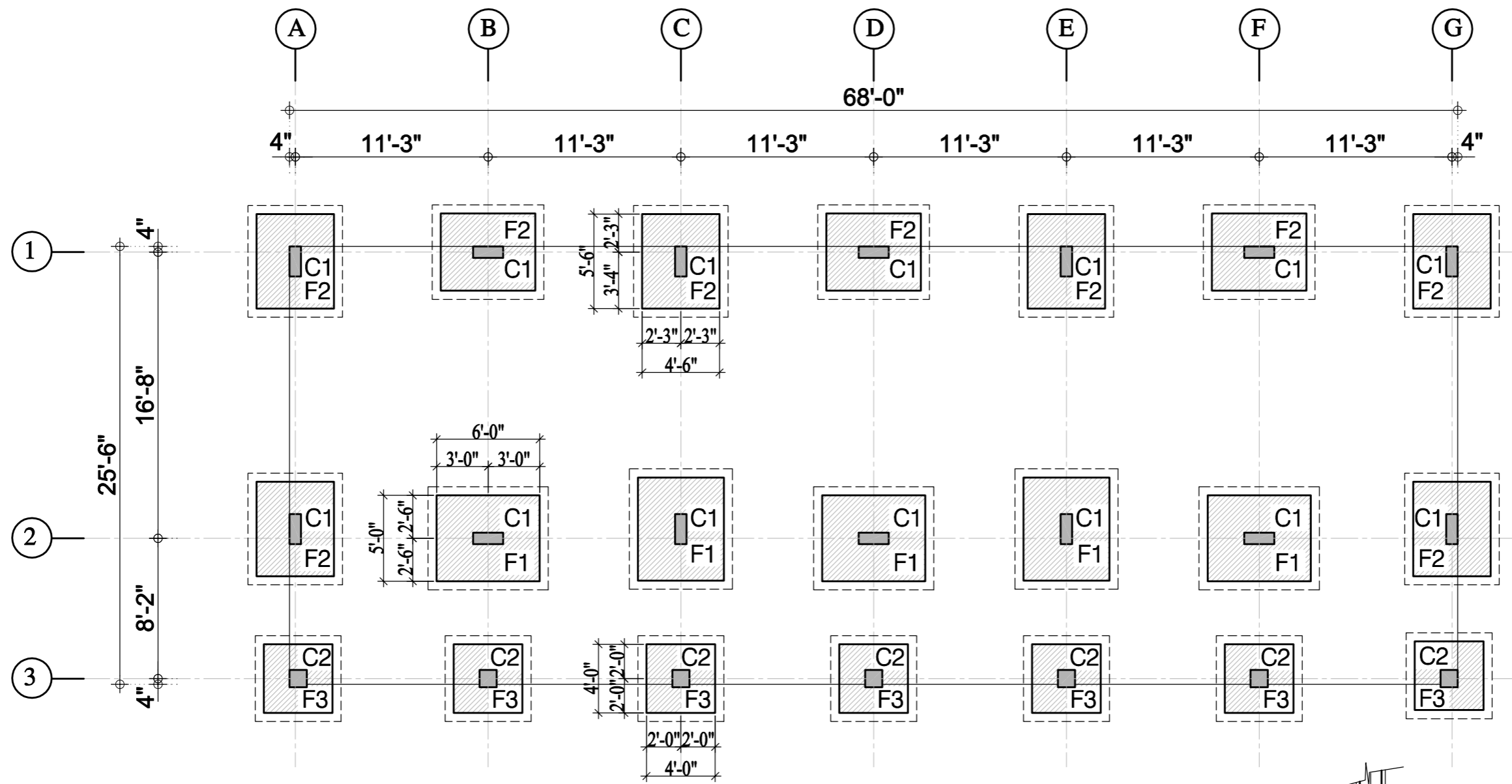

### FOUNDATION LAYOUT PLAN

SCHEDULE OF FOOTING									
MARK	SIZE 1:4:8		SIZE 1:2:4		FOOTING DEPTH H	REINFORCEMENT			
	A	B	C	D		SHORT SPAN (R/F)		LONG SPAN	
	TOP	BOTTOM	TOP	BOTTOM					
F-1	6'-0"	7'-0"	5'-0"	6'-0"	18"	---	1/2"Ø@5"c/c	---	1/2"Ø@5"c/c
F-2	5'-6"	6'-6"	4'-6"	5'-6"	18"	---	1/2"Ø@5"c/c	---	1/2"Ø@5"c/c
F-3	5'-0"	5'-0"	4'-0"	4'-0"	18"	---	1/2"Ø@5"c/c	---	1/2"Ø@5"c/c

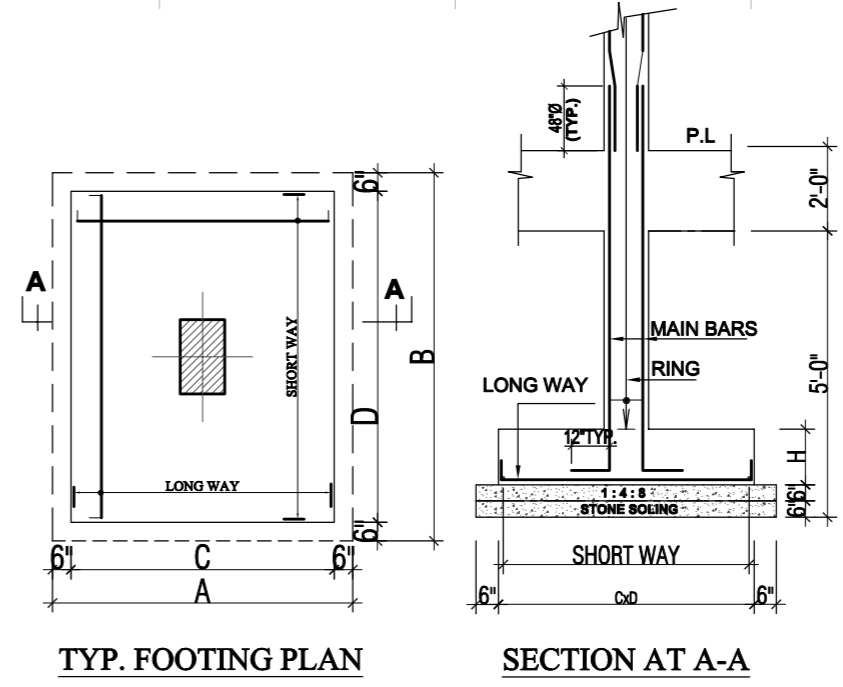

TYP. FOOTING PLAN

SECTION AT A-A

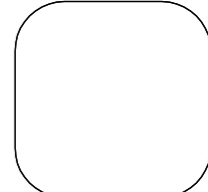
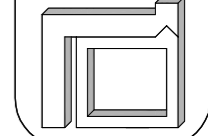

DESIGNED BY:	REV.
M.FAREED QURESHI	
ENGR.GAMAR JAWAID	
ENGR.GAMAR JAWAID	
SCALE: N.T.S	
DATE:	

PROJECT TITLE:  
 03 CLASS ROOMS BUILDING FOR PRIMARY SCHOOL  
 BUILDING TYPE:  
 PLINTH BEAM LAYOUT PLAN

SHEET REFERENCE NUMBER  
**S-03**  
 SHEET OF \_

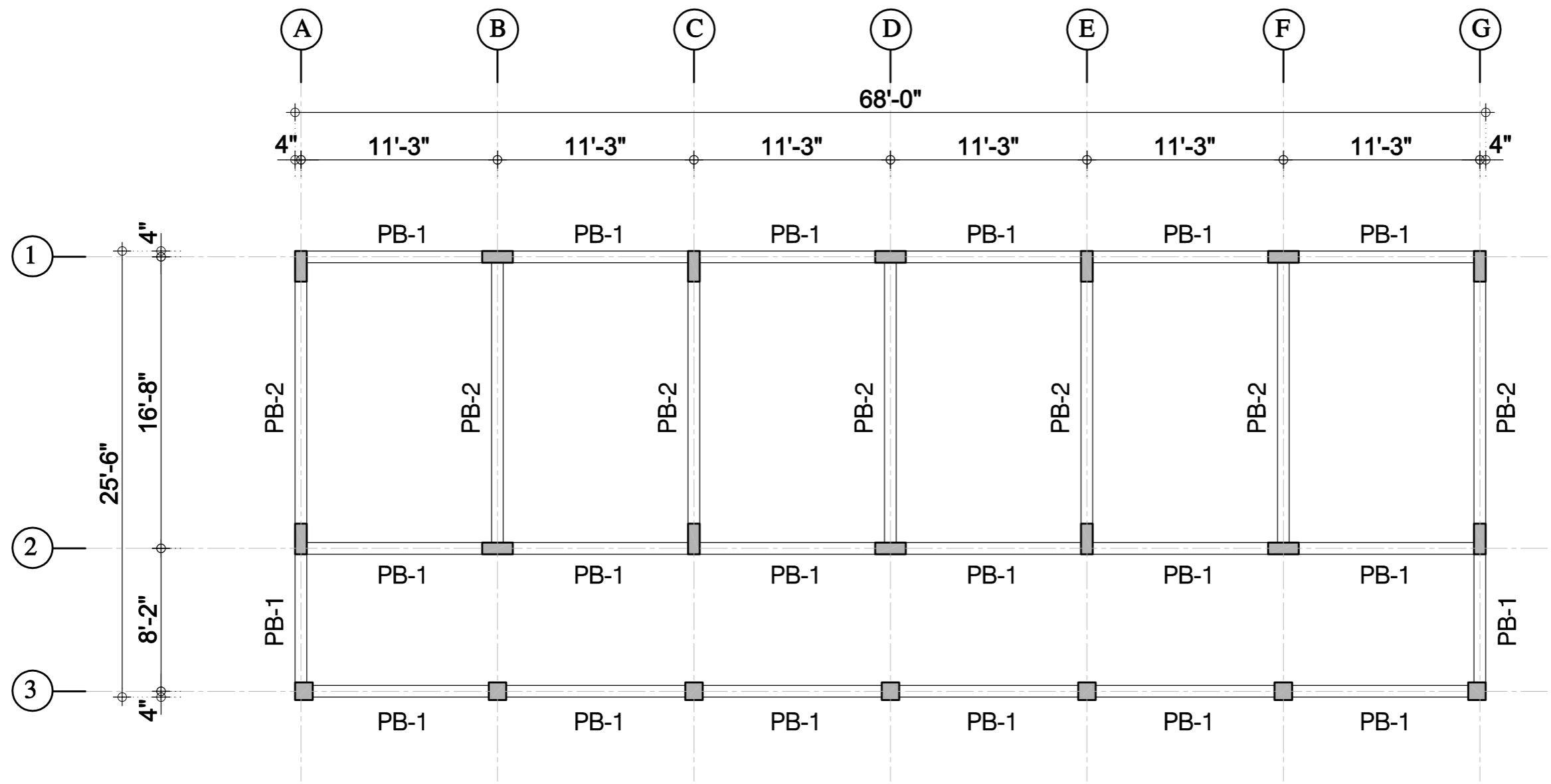

**PLINTH BEAM LAYOUT PLAN**

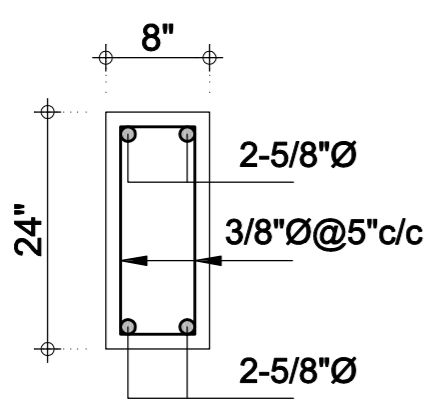

**PB-1(8"x24")**

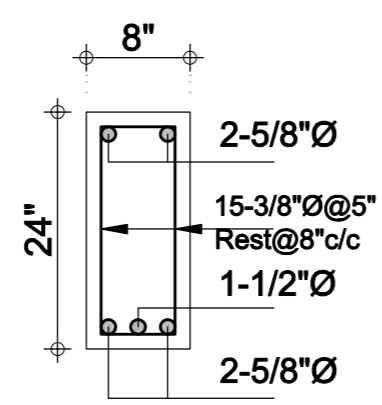

**PB-2(8"x24")**

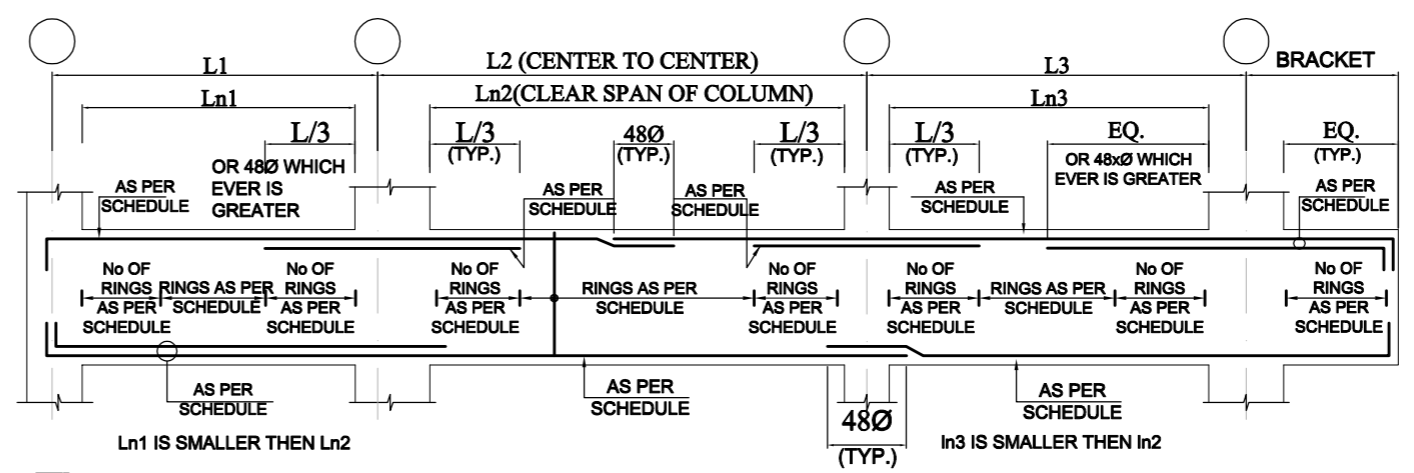

**TYP. ELEV. OF PLINTH BEAM**

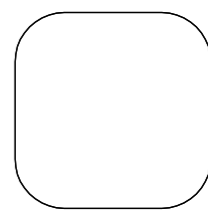

DESIGNED BY:	REV.
M.FAREED QURESHI	
ENGR.QAMAR JAWAID	
ENGR.QAMAR JAWAID	
SCALE:	N.T.S
DATE:	

PROJECT TITLE:  
 03 CLASS ROOMS BUILDING FOR PRIMARY SCHOOL  
 BUILDING TYPE:  
 FRAMING LAYOUT PLAN

SHEET REFERENCE NUMBER  
**S-04**  
 SHEET OF \_

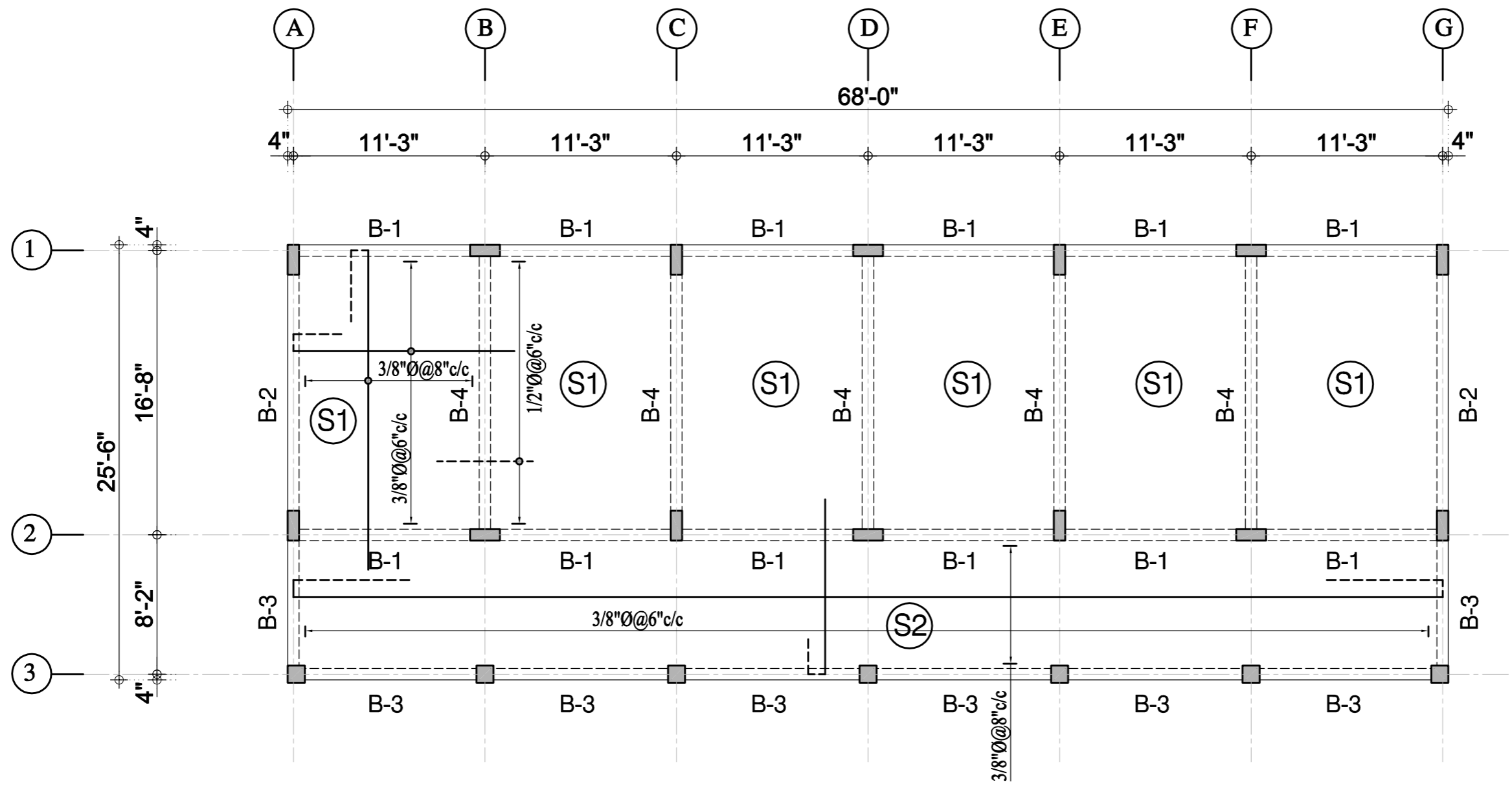

**FRAMING LAYOUT PLAN**

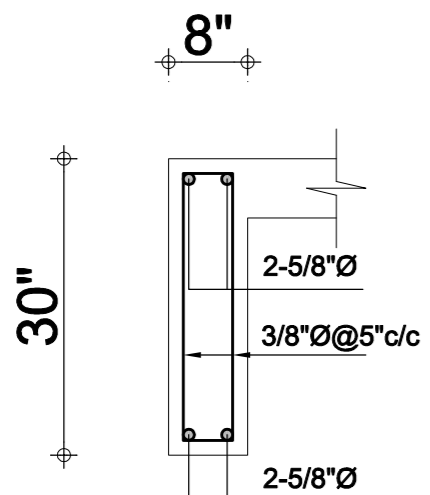

**B-1(8"x30")**

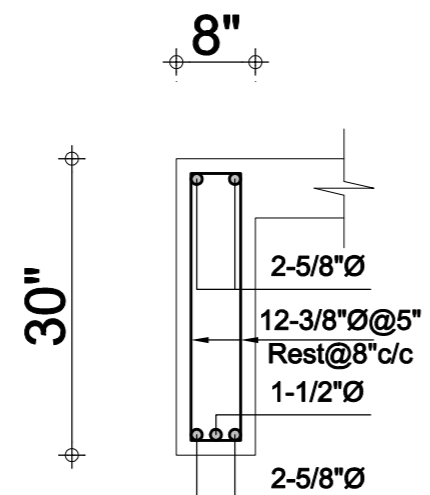

**B-2(8"x30")**

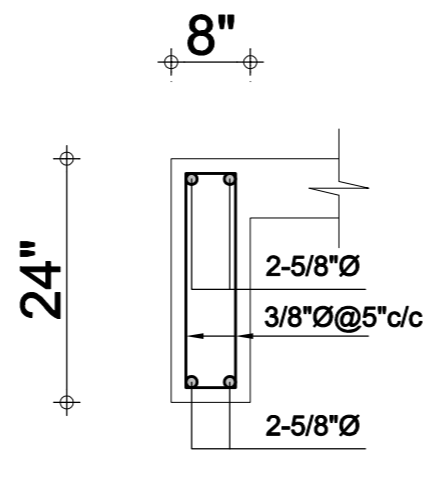

**B-3(8"x24")**

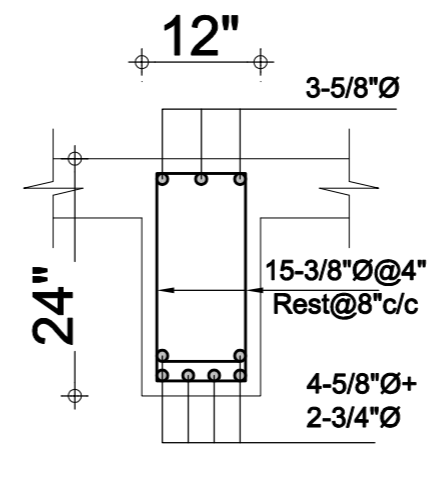

**B-4(12"x24")**

**BILL OF QUANTITIES (BASED ON CSR-2024)**

Name Of Scheme: Construction / Re-Construction of Existing Schools in Sindh Affected under Rain / Flood 2022  
(07 Units) (ADP No. 2301 of 2025-26) PSDP / ADP SCHEME DISTRICT KAMBER SHAHDADKOT (PACKAGE NO.  
49) @ 01) GBPS ALLAH RAKHIO CHOLIANI (SEMIS ID 427040235) & 02( GBPS DENGAL MACHI TALUKA  
WARAH (SEMIS ID 427040206)

**ESTIMATED COST:****33,549 MILLION****Package # 49 District Kambar**

Part	Components	Amount in Figures	Amount in Words
<b>A</b>	<b>CIVIL WORKS:</b>		
	<b>COST OF SCHEDULE ITEM:</b>	<b>26,080,963.00</b>	
	@ _____ % Above / Below		
	<b>TOTAL PART-A (CIVIL WORK):</b>		
<b>B</b>	<b>W/S &amp; S/F WORKS:</b>		
	<b>COST OF SCHEDULE ITEM:</b>	<b>1,080,737.00</b>	
	@ _____ % Above / Below		
	<b>TOTAL PART-B (W/S &amp; S/F):</b>		
<b>C</b>	<b>ELECTRICAL WORKS:</b>		
<b>I)</b>	<b>COST OF SCHEDULE ITEM:</b>	<b>1,641,633.00</b>	
	@ _____ % Above / Below		
	<b>SUB TOTAL SCHEDULE ITEMS:</b>		
<b>II)</b>	<b>COST OF NON-SCHEDULE ITEM:</b>		
	<b>TOTAL PART-C (ELECTRIFICATION)</b>		
	<b>G. TOTAL COST (A+B+C):</b>		
	<b>Add: 2.50% SRB on G. Total (For GOS Share)</b>		
	<b>TOTAL QUOTED AMOUNT:</b>		

The Quoted Amount is Rs. \_\_\_\_\_ (in figures), (Rupees: \_\_\_\_\_ )

I/ We have attach a Bid Security as per NIT in shape of pay order bearing No. \_\_\_\_\_, Dated: \_\_\_\_\_, Amounting to Rs. \_\_\_\_\_, issued from \_\_\_\_\_ Bank / Branch.

I/We have read all existing terms & conditions of NIT under the provision of SPP Rules 2010 (amended time to time) and agreed to abide all of them. I/We have offered that above rates after taking into consideration all the terms and conditions as per B-I, printed tender & this memorandum and shall be base to fill-up & completed the B-I, tender form co, as to complete the agreement. In case of failure, the Department will be at liable to take action against me/us.

**NOTE:**

- Tender must be quoted in figure & words both otherwise liable to be cancelled.
- All overwriting & Corrections if any must be initialed and stamped by the Bidder.
- All prevailing rules regarding condition of contract will be applicable.

**Signature of the Contractor with Stamp**

## Bill Of Quantity

**Name Of Scheme: Construction / Re-Construction of Existing Schools in Sindh Affected under Rain / Flood 2022 (07 Units) (ADP No. 2301 of 2025-26) PSDP / ADP SCHEME DISTRICT KAMBER SHAHDADKOT (PACKAGE NO. 49) @ 01) GBPS ALLAH RAKHIO CHOLIANI (SEMIS ID 427040235) & 02( GBPS DENGAL MACHI TALUKA WARAH (SEMIS ID 427040206)**

### **Construction Of 03 Class Rooms. (Main Building)**

S. #	DESCRIPTION	Qty:	Rate	Unit	Amount
<b>A</b>	<b>Schedule Items</b>				
1	Dismantling cement concrete reinforced separating reinforced cement from concrete cleaning and straightening the same. (S.I No.20 / P.20)	1,982	229.72	P.Cft	455,305
2	Dismantling 2nd Class tile roofing. (S.I No.22 (b) / P.20)	226	15.84	P.Cft	3,580
3	Dismantling brick work in lime or cement mortar. (S.I No.13 / P.19)	3,266	59.41	P.Cft	194,033
4	Excavation in foundation of Building Bridges and other structures including Dag belling dressing, refilling around structure with excavated earth Watering and ramming lead up to 5 ft, lead up to one chain (30 meter) and lift up to 5 ft. (1.5 meter). b) In ordinary soil. (S.I No 18 / P 17)	8,534	11.88	P.Cft	101,384
5	Cement concrete brick or stone ballast 1-1/2" to 2" gauge. (S.I No.4 / P.24) Ratio 1:4:8	1,607	296.69	P.Cft	476,632
B)	Ratio 1:5:10	2,100	277.38	P.Cft	582,498
6	Reinforced cement concrete work including all labour and material except the cost of steel reinforcement and its labour for bending and binding which will be paid separately. This rate also includes all kinds of forms mould, lifting, centering, shuttering and curing. (including screening and washing of shingle) a) R.C.C work in roof slab, beams, column, rafts, lintels and other structural members laid in situ or precast laid in position complete in all respects. (S.I No.6 (i) / P.25)	7,225	717.59	P.Cft	5,184,595
7	Reinforced cement concrete work including all labour and material except the cost of steel reinforcement and its labour for bending and binding which will be paid separately. This rate also includes all kinds of forms mould, lifting, centering, shuttering and curing. (including screening and washing of shingle) a) R.C.C work in roof slab, beams, column, rafts, lintels and other structural members laid in situ or precast laid in position complete in all respects. (S.I No.6 (i) / P.25) <b>First Floor</b>	356	767.50	P.Cft	273,230

S. #	DESCRIPTION	Qty:	Rate	Unit	Amount
8	Fabrication of deformed steel reinforcement for cement concrete including cutting, bending, laying in position, making joints and fastenings including cost of binding wire (also includes removal of rust from bars) a) Deformed bar i) Grade 60 (S.I No.8 / P.26)	351	18934.02	P.Cwt	6,645,841
9	Fabrication of deformed steel reinforcement for cement concrete including cutting, bending, laying in position, making joints and fastenings including cost of binding wire (also includes removal of rust from bars) a) Deformed bar i) Grade 60 (S.I No.8 / P.26) <b>First Floor</b>	18	19726.17	P.Cwt	355,071
10	Erection & removal of centering for R.C.C. or plain c.c.work or deodar wood (2nd class) (ii) for vertical (P/13-19-b).	1,344	220.36	P.Sft	296,164
11	Cement concrete plain 1:3:6 i/c placing compacting, finishing and curing complete (i/c screening and washing of stone aggregate without shuttering. (S.I No. 5-h/P-11)	450.00	388.67	P.Sft	174,902
12	Pacca brick work other than building including striking of joints upto 10ft. (3 meter) height (e) Cement sand mortar. 1:6 (S.I No. 7 (e) /P-31)	1,296.00	362.88	P.Cft	470,292
13	Pacca brick work in foundation and plinth in: (i) e) Cement sand mortar 1:6 (S.I No.4 / P.29)	1,974	359.20	P.Cft	709,061
14	Supplying and filling sand under floor and plugging in walls. (S.I.No 29 / P.34)	32,032	57.52	P.Cft	1,842,481
15	Pacca brick work in ground floor in (including striking of joints) (i) e) Cement sand mortar Ratio 1:6 (S.I No.5 / P.30)	1,514	381.18	P.Cft	577,107
16	Providing and fixing G.I frames /Chowkats of size 7" x 2" or 4 1/2" x 3" for door using 20 gauge G.I sheet I/c welded hinges and fixing at site with necessary hold fasts, filling with cement sand slurry of ratio 1:6 and repairing the jambs. The cost also i/c all carriage, tools and plants used in making and fixing. (S.I No 29 / P.76)	266	690.67	P.Rft	183,718
17	Providing and fixing G.I frames /Chowkats of size 7" x 2" or 4 1/2" x 3" for windows using 20 gauge G.I sheet I/c welded hinges and fixing at site with necessary hold fasts, filling with cement sand slurry of ratio 1:6 and repairing the jambs. The cost also i/c all carriage, tools and plants used in making and fixing. (S.I No 28 / P.76)	1,068	908.25	P.Rft	970,011
18	M.S Milled Bars. (Schedule of Material Item No.146 / P.25)	6	12212.32	P.Cwt	73,274

S. #	DESCRIPTION	Qty:	Rate	Unit	Amount
19	Cutting and fixing iron bars for barred windows. (S.I No.18 / P.75)	144	111.55	P.Bar	16,063
20	Cement plaster 1:6 up to 12' up to 20 ft height b) 1/2" thick. (S.I No.13 / P.52)	17,911	37.01	P.Sft	662,876
21	Cement plaster 1:4 up to 12' height a) 3/8" thick. (S.I No.11 / P.52)	17,911	37.78	P.Sft	676,667
22	Cement concrete plain including placing compacting, finishing and curing, complete (including screening and washing at stone aggregate without shuttering. f) Ratio 1:2:4 (S.I.No.5 / P.24)	446	443.54	P.Cft	197,819
23	Providing and laying 1" thick topping of cement concrete (1:2:4 ) including Surface finishing and dividing into panels: c) 2" Thick (S.I No:16 / P.45)	4,108	108.75	P.Sft	446,745
24	P/F 3/8" thick Marble Tiles of Approved Quality & Colour & Shade size 8"x4" or 6"x4" in dado Skirting & facing removal tucking of existing plaster surface etc. Over 1/2" thick base of cement mortar 1:3 setting of tile in slurry of white cement over motor base I/c filling & joints & washing the tile with white cement slurry current finishing cleaning & polishing etc, complete (New Work) (S.I No.61 / P.49)	354	247.28	P.Sft	87,537
25	Laying floors of approved coloured glazed tiles 1/4" thick floor of approved color & size jointing in white cement and laid over 1:2 cement sand mortar 3/4" thick including grouting with matching color and finishing. (S.I No.25 / P.46)	186	325.40	P.Sft	60,524
26	Laying floor of approved with glazed tiles 1/4" thick dado of approved color & size jointing in white cement and laid over 1:2 cement sand mortar 3/4" thick including grouting with matching color and finishing. (S.I No.24 / P.45)	418	389.36	P.Sft	162,752
27	Making and fixing Notice board Lassani / MDF Sheet with lamination coating in/c wooding leaping beading cost of hooks nails etc complete. (S.I No.114 / P.87)	192	870.82	P.Sft	167,197
28	Supplying & fixing in position iron/steel grill of 3/4" x 1/4" size flat iron of approved design including painting 3 coats etc. complete (weight not to be less than 3.7 Lbs./Sq . Foot of finished grill) (S.I No:26 / P.76)	14	1124.10	P.Sft	15,737

S. #	DESCRIPTION	Qty:	Rate	Unit	Amount
29	Providing and fixing iron steel grill door with angle iron frame of 1 1/2" x 1 1/2" x 1/4" and flat iron of 3/4" x 1/4" with approved design and locking arrangement embedded in Masonry as per instructions of Engineer in charge. (S.I No.31 / P.76)	54	1037.86	P.Sft	56,044
30	Kail wood wrought, joinery in doors and windows etc fixed in position in/c chowkats hold fasts hinges iron tower bolts chocks cleats handles and cords wit hooks etc kail panel or paneled and glazed or fully glazed 1-3/4" thick (Only Shutters). (Only Shutter) (S.I No.107 / P.86)	510	1334.33	P.Sft	680,508
31	Laying Verona marble flooring Size 24" x 12" x 1"/12" x 12" x 1" fine dressed on the surface without winding set in lime mortar 1:2 including rubbing and polishing of the joints. a) 3/4" Thick (S.I No.28 (iii) / P.46)	2,782	369.59	P.Sft	1,028,199
32	Priming coat of chalk under distemper. (S.I No.23 / P.53)	3,356	3.59	P.Sft	12,048
33	Distemping. (c) three coats (S.I No.24 / P.53)	3,356	17.23	P.Sft	57,824
34	Preparing the surface and painting with matt finish I/c rubbing the surface with Bathy (silicon carbide rubbing brick) filling the voids with Zink /chalk / plaster of Paris mixture, applying first coat premix, making the surface smooth and then painting 3 coats with matt finish of approved make etc: complete. (new surface) (S.I No.36 (a) / P.54)	8,084	49.27	P.Sft	398,299
35	Preparing the surface and painting with weather coat I/c rubbing the surface with rubbing brick / sand Paper, filling the voids with chalk/ plaster of Paris and then painting with weather coat of approved make. (S.I No.38 / P.54)	8,325	86.58	P.Sft	720,779
36	Making and fixing steelgrated door with 1/16" thick sheeting i/c angle iron frame 2"x2"x3/8" and 3/4" thick sq barss 4" c/c with locking arrangement (S.I.No.24/p-63).	120	2726.96	P.Sft	327,235
37	Difference of S.R.C Cement Bag (S.I.NO. 45/B/P20),	256.00	50.00	P.Bag	12,800
38	Painting guard barss gates iron barss grating railing i/c stander bcaesthree coats similer open work (three Coats).(S.I.No.4/d/p-62)..	240.00	24.00	P.Sft	5,760
39	Painting New Surface: c) Preparing surface and painting doors and windows any type. (including edges) (S.I No.5 / P.63)	1,736	25.52	P.Sft	44,303

S. #	DESCRIPTION	Qty:	Rate	Unit	Amount
40	Laying Murum flooring consisting of 1" (25m) layer of fine powdery or flakey variety of Murum laid over 6" (150mm) good hard layer of Murum spread over 9" (225mm) thick sub-base comprising of hand packed rubble or broken bricks properly watered and rammed provided over well rammed earth. (S.I No.1 / P.44)	2,260	100.78	P.Sft	227,763
41	Providing & fixing cement paving blocks flooring having size of 197 x 97 x 60 (mm) of city /quddra / cobble shape with natural colours , having strength b/w 5000 PSI to 8500 PSI i/c filling the joints with hill sand over a bed of 2" thick hill sand or stone dust and laying and compacting in specified manner/ pattern and design etc complete. (S.I No.67 / P.50)	2,260	197.48	P.Sft	446,305

				Total Rs:	26,080,963
<b>B)</b>	<b>W/S &amp; S/F</b>				
1	Providing and fixing squatting type white glazed earthen ware W.C. pan with front flush inlet & complete with including the cost of flushing cistern with internal fitting and flush pipe with bend and making requisite number of holes in walls, plinth & floor for pipe connection & making good in cement concrete 1:2:4.(19 inch clear). (S.I No.1-B (i) / P.184)	4	10240.50	Each	40,962
2	Providing and fixing 24"x18" lavatory basin in white glazed earthen ware complete with & including the cost of W.I. or C.I. cantilever bracket 6 inches built into wall, painted white in two coats after a primary coat of red lead paint, a pair of 1-1/2" dia chrome plated pillar taps, 1-1/2" rubber plug & chrome plated brass chain 1-1/4" dia malleable iron or C.P. brass traps malleable iron or brass unions and making requisite number of holes in walls, plinth & floor for pipe connection & making good in cement concrete 1:2:4 (Foreign Equivalent) (S.I No.10 / P.187)	4	24094.98	Each	96,380
3	Add extra for providing & fixing of earth ware pedestal white or coloured Glazed (Foregin or equivalent) (S.I No.11 / P.187)	4	3675.07	Each	14,700
4	Providing and fixing in position nylon connection complete with " dia brass stop cock with pair of brass nuts and lining jointed to nylon connection. (S.I No.23 / P.189)	8	637.65	Each	5,101
5	S/fixing concealed Tee-stop cock of superior quality with Crystal head 1/2" dia. (S.I No.12 (b) / P.198)	8	1673.10	Each	13,385

S. #	DESCRIPTION	Qty:	Rate	Unit	Amount
6	Supplying & fixing long Bib -cock of Crystal head with C.Phead 1/2" dia. (S.I No.13 (b) / P.198)	8	2784.60	Each	22,277
7	Supplying & fixing swan type pillar cock of superior quality with Crystal head 1/2" dia. (S.I No.16 (b) / P.199)	4	1848.60	Each	7,394
8	Providing chambers 15"x19" (inside dimension) x24" deep for house meters with 6" thick C.C 1:2:4 blocks set in 1:6 cement mortar 6" thick C.C 1:4:8 in foundation, " thick cement plaster 1:3 to all inside wall surfaces and to top 1" thick C.C. 1:2:4. (S.I No.2 / P.200)	8	9051.80	Each	72,414
9	Providing and Fixing Handle Value. c) 1" dia (S.I No.5 / P.197)	4	1907.10	Each	7,628
10	providing and fixing full way gun metal values with wheels, threaded or flanged end with rubber washer. (b) iv) 1-1/4" Dia (Standard Pattern) (S.I No.4 / P.197)	2	1556.10	Each	3,112
11	Providing UPVC pipes specials and clamps etc including fixing cutting and fittings complete with and including the cost of breaking through walls and roof making good etc. with pigment to match the colour of the building and testing with water to a pressure bead of 200 feet and handling. (S.I No.2 / P.193)				
a)	1/2" Dia	100	159.30	P.Rft	15,930
b)	3/4" Dia	400	199.83	P.Rft	79,932
c)	1" Dia	200	272.35	P.Rft	54,470
d)	2" Dia	100	465.53	P.Rft	46,553
e)	4" Dia	200	836.36	P.Rft	167,272
f)	6" Dia	374	950.38	P.Rft	355,442
12	P/F Elbow (CPVC SCH-40) Sanitary Tape/Sofaida I/C all Labour. (S.I No.5 / P.194)				
a)	3/4" Dia	30	550.37	Each	16,511
b)	1" Dia	12	586.40	Each	7,037
c)	4" Dia	6	1528.49	Each	9,171
13	P/F Tee (CPVC SCH-40) Sanitary Tape/Sofaida I/C all Labour. (S.I No.10 / P.194)				
a)	3/4" Dia	16	491.68	Each	7,867
b)	1" Dia	4	512.27	Each	2,049
c)	4" Dia	4	1106.35	Each	4,425
14	P/F Socket (CPVC SCH-40) Sanitary Tape/Sofaida I/C all Labour. (S.I No.6 / P.194)				
a)	3/4" Dia	12	560.66	Each	6,728
b)	1" Dia	6	570.96	Each	3,426

S. #	DESCRIPTION	Qty:	Rate	Unit	Amount
15	P/F 6" x 4" c.c gully trap with 4" dia out let complete with 4" thick 1:2:4 c.c for bed and 1/2" thick cement plaster 1:3 to the karb c.I caning 6" x 6" and c.I cover and frame 12" x 12" in side etc complete. 4" Dia (S.I No.1 (a-i) / P.203)	2	3037.32	Each	6,075
16	P/F "Y" tee 4" dia (CPVC SCH-40) sanitary Tape/Sofaida i/c all Labour. (S.I No.7(d)/P.194)	4	1100.17	Each	4,401
17	P/F Elbow 4" (CPVC SCH-40) Sanitary Tape/Sofaida I/C all Labour. (S.I No.5 (d) / P.194)	4	1528.49	Each	6,114
18	P/F Union (CPVC SCH-40) Sanitary Tape/Sofaida I/C all Labour. (S.I No.3 (a) / P.193)	2	610.08	Each	1,220
19	Providing and Fixing ball valves with Plastic Ball & Road d) 1-1/4" dia (S.I No.6 / P.198)	2	1380.60	P.No	2,761
<b>Total Rs:</b>					<b>1,080,737</b>

<b>C) Electrification (Shedule Item)</b>					
1	Wiring for light or fan point with 3/.029 PVC insulated wire in 20 mm(3/4") PVC conduct recessed in the wall or columns as required(SINO: 102/P-236)	80	6573.50	P.Point	525,880
2	Wiring for Plug point with 3/.029 PVC insulated wire 20mm(3/4") conduit recessed in the wall or columns as required (SINO: 104/P-236)	18	4372.29	P.Point	78,701
3	Providing and laying (Main or Sub-Main) PVC insulated with size (2-7/.029) copper conductor in 3/4" dia PVC conduct in the wall or coumns as required (SINO: 10/P-229)	802	400.92	P.Rft	321,538
4	Providing and laying (Main or Sub-Main) PVC insulated with size (2-7/.044) copper conductor in 3/4" dia PVC conduit recessed in the wall or coumns as required (SINO: 12/P-229)	120	660.91	P.Rft	79,309
5	Providing and fixing Brass Battern holder. (SINO: 193/P-244)	48	1152.61	P.Point	55,325
6	Providing and fixing Baklite ceiling Rose with two terminals (SINO: 191,P-244)	24	373.39	P.No	8,961
7	Providing and fixing circuit breaker 6,10,15,20,30,40,50 & 63 amp SP (TB+5S) on prepared board as required (SINO: 178/P-243)	12	2504.12	P.No	30,049
8	Providing and fixing circuit breaker 6,10,15,20,30,40,50 & 63 amps DP (TB-5S) on prepared board as required. (SINO: 179/P-243)	2	5528.57	P.No	11,057

S. #	DESCRIPTION	Qty:	Rate	Unit	Amount
9	Providing And Fixing One way SP 10/15 Amp Switch surface type (S.I.No: 188 P 244 ) Schedule Book 2024	80	468.19	P.No	37,455
10	Providing and fixing three pin plug and sockets 15 amps fancy type Board and sheet i/c necessary connection (R.A) (S.I.No. 190/P-244). Schedule Book 2024	2	677.36	P.No	1,355
11	P/Fixing 2 pin plug 10/15 amps Plug & Sockets Flush Type (S.I.No: 189 P 244 )(2024) Schedule Book 2024	10	617.69	P.No	6,177
12	Providing & Fixing DP i/c change over switch 500 volts 100 Amp on prepared board as required(SINo: 172/P-243) Schedule Book 2024	2	34291.54	P.No	68,583
13	Providing & Fixing earthing set Copper Plate i/c Excavation of rock earth 12ft depth or if water comes out i/c salt/choracale mixed with G.I Pipe with nuts bolts testing topping etc complete (1x1) (SINo: 252/P-249) Schedule Book 2024	2	30191.00	P.No	60,382
14	Providing & Fixing A.C Electric Ceiling Fans 56" (Good Quality) (SINO:195/P-244)	24	14869.21	P.No	356,861
<b>Total Rs: S.I</b>					<b>1,641,633</b>
<b>Electrification (Non-Shedule Item)</b>					
15	Providing & Fixing double shuter for accommodate circiut breaker and busbar i/c painting with enemelled pain.(RA)	2.50		P.No	
16	P/F Energy saver superior quality i/c fixing on extg: holder etc complete. (R.A)	48		P.No	
17	P/ F ceiling mounted light fancy type superior quality i/c necessary electric connection an with holder without energy saver etc (R.A)	12		P.No	
18	Providing and fixing Midl steel bar fan clamps 15.8 mm (5/8") dia suitable for RCC roof (R.A)	24		P.No	
19	Providing and fixing Solar panels 300 Watts Mono Perc Grade A Tier Solar Panels	6		P.No	
20	Iron made powder coated rust proof mounting plate	6		P.No	
<b>Total Rs: N.S.I</b>					

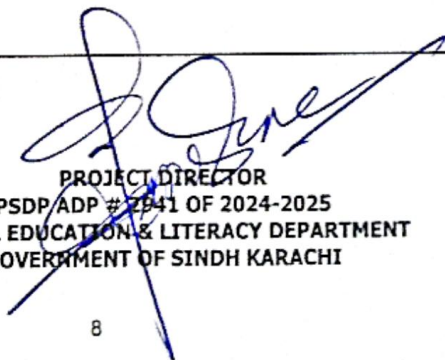
  
**PROJECT DIRECTOR**  
 PSDP/ADP # 2841 OF 2024-2025  
 SCHOOL EDUCATION & LITERACY DEPARTMENT  
 GOVERNMENT OF SINDH KARACHI