

22 APR 2026

**National Grid Company of Pakistan Limited (NGC)**

**INVITATION FOR BIDS**

**TENDER No.CE-AM-NGC-MN-03-2025-26**

1. National Grid Company of Pakistan (NGCP) "the Employer", intends to procure material for (Tender No. CE-AM-NGC-MN-03-2025-26) through NGCP own resources. The Scope for supply of quantities of Goods includes the following:

Sr.No.	Description	Quantity Required
1	Procurement of Liveries/Uniform item for Security Staff (Asset Management) North Region NGC Multan	As per Tender documents

2. The Employer invites sealed bids through "Single Stage two Envelope (SSTE) Procedure" on National Competitive Bidding (NCB) basis from eligible firms as defined under IB-3 Instructions to Bidders of the Bidding Documents, registered with Income Tax and Sales Tax Departments and who are on Active Tax payers List of the Federal Board of Revenue and registered with PEC.

3. Bidders may obtain further information from Employer from address below:

Chief Engineer (A.M) North,NGC Multan  
GSO House, Sher Shah Road, Cantt. Multan  
Telephone No. 92-61-9200515  
Fax No. 92-61-9200516

4. Bid Security amounting to Rs. 150,000/- in the form of Deposit at Call or a Bank Guarantee issued by a Scheduled Bank in Pakistan favor of "Chief Engineer WAPDA NTDC" the Employer valid for a period up to Twenty- Eight (28) days beyond the bid validity date.

5. The bids must be submitted through EPADS on or before 11.05.2026 before 14:30HRS However, the Bid security is required to be submitted in original from bid closing deadline. Technical bids will be opened at 15:00HRS on the same day, in the presence of the Bidder's representatives who choose to attend at the same address.



6. The bids must be submitted through e-PADS as well before the prescribed time.

NGCP reserves its rights regarding rejection of bids as defined in clause 33(1) of PPRA Rules 2004.

PID(L)2876/25

**Chief Engineer (Asset Management)  
North, NGC Region Multan**

22 APR 2026

 **National Grid Company of Pakistan Limited (NGC)** 

**INVITATION FOR BIDS**  
**TENDER No.CE-AM-NGC-MN-03-2025-26**

1. National Grid Company of Pakistan (NGCP) "the Employer", intends to procure material for (Tender No. CE-AM-NGC-MN-03-2025-26) through NGCP own resources. The Scope for supply of quantities of Goods includes the following:

Sr.No.	Description	Quantity Required
1	Procurement of Liveries/Uniform item for Security Staff (Asset Management) North Region NGC Multan	As per Tender documents

2. The Employer invites sealed bids through "Single Stage two Envelope (**SSTE**) Procedure" on National Competitive Bidding (NCB) basis from eligible firms as defined under B-3 Instructions to Bidders of the Bidding Documents, registered with Income Tax and Sales Tax Departments and who are on Active Tax payers List of the Federal Board of Revenue and registered with PEC.

3. Bidders may obtain further information from Employer from address below:  
Chief Engineer (A.M) North, NGC Multan  
GSO House, Sher Shah Road, Cantt. Multan  
Telephone No. 92-61-9200515  
Fax No. 92-61-9200516

4. Bid Security amounting to Rs.150,000/- in the form of Deposit at Call or a Bank Guarantee issued by a Scheduled Bank in Pakistan favor of "**Chief Engineer WAPDA NTDC**" the Employer valid for a period up to Twenty- Eight (28) days beyond the bid validity date.

5. The bids must be submitted through EPADS on or before 11.05.2026 before 14:30HRS However, the Bid security is required to be submitted in original from bid closing deadline. Technical bids will be opened at 15:00HRS on the same day, in the presence of the Bidder's representatives who choose to attend at the same address.

6. The bids must be submitted through e-PADS as well before the prescribed time.

NGCP reserves its rights regarding rejection of bids as defined in clause 33(1) of PPRA Rules 2004. PID(L)2876/25

**Chief Engineer (Asset Management)**  
**North, NGC Region Multan**

**NGC**

**NATIONAL GRID COMPANY OF PAKISTAN LIMITED**

**TENDER NO. CE-AM-NGC-MN-03-2025-26**

**PROCUREMENT OF LIVERIES/UNIFORM  
ITEM FOR SECURITY STAFF (ASSET  
MANAGEMENT) NORTH REGION NGC  
MULTAN**

**UNDER NGC's OWN RESOURCES**



**CHIEF ENGINEER ASSET MANAGEMENT NORTH NGC  
MULTAN  
APRIL, 2026**

**SECTION-I**

**INSTRUCTIONS  
TO  
BIDDERS**

# **INSTRUCTIONS TO BIDDERS**

## **A. GENERAL**

### **IB.1 Scope of Bid**

- 1.1 The Purchaser as defined in the Bidding Data hereinafter called “the Purchaser” wishes to receive bids for the supply of Engineering Goods as described in these Bidding Documents, and summarized in the Bidding Data hereinafter referred to as the “Goods”.
- 1.2 The successful Bidder will be expected to supply the Goods within the time specified in the Bidding Documents.
- 1.3 All Goods to be supplied under the Contract shall have as their country of origin an eligible country as per Appendix-A to Bid.
- 1.4 For purposes of this Clause, the term “Goods” includes commodities, raw material, machinery, equipment, and industrial plants.
- 1.5 The term “country of origin” means the country where the goods have been mined, grown, cultivated, produced, manufactured, or processed; or through manufacture, processing, or assembly, another commercially recognized article results that differs substantially in its basic characteristics from its imported components.
- 1.6 The nationality of the firm that produces, assembles, distributes, or sells the goods shall not determine their origin.
- 1.7 The bidding is open to National Competitive Bidding as indicated in the Bidding Data.

### **IB.2 Source of Funds**

- 2.1 The Purchaser has applied for/received a loan/credit from the source (s) indicated in the Bidding Data in various currencies towards the cost of the project specified in the Bidding Data and it is intended that part of the proceeds of this loan/credit will be applied to eligible payments under the Contract for which these Bidding Documents are issued.

### **IB.3 Eligible Bidders**

- 3.1 This Invitation for Bids is open to all Bidders meeting the following requirements:
  - a. A Bidder having the nationality of an eligible country in accordance with Appendix A to Bid.
  - b. Duly prequalified / enlisted with the Purchaser.

### **IB.4 One Bid per Bidder**

- 4.1 Each Bidder shall submit only one bid either by himself, or as a partner in a joint venture. A Bidder who submits or participates in more than one bid (other than alternatives pursuant to Clause IB.20) will be disqualified.

**IB.5 Cost of Bidding**

- 5.1 The Bidders shall bear all costs associated with the preparation and submission of their respective bids and the Purchaser will in no case be responsible or liable for those costs, regardless of the conduct or outcome of the bidding process.

**IB.6 Site Visit**

- 6.1 The Bidders are advised to visit and inspect the Location of Delivery and its surroundings and obtain for themselves on their own responsibility all information that may be necessary for preparing the bid and entering into a Contract for Supply of Goods. All cost in this respect shall be at the bidder's own expense.
- 6.2 The Bidders and any of their personnel or agents will be granted permission by the Purchaser to enter upon his premises and lands for the purpose of such inspection, but only upon the express condition that the Bidders, their personnel and agents, will release and indemnify the Purchaser, his personnel and agents from and against all liability in respect thereof and will be responsible for death or personal injury, loss of or damage to property and any other loss, damage, costs and expenses incurred as a result of such inspection.

**B. BIDDING DOCUMENTS****IB.7 Contents of Bidding Documents**

- 7.1 The Bidding Documents, in addition to Invitation for Bids, are those stated below and should be read in conjunction with any Addenda issued in accordance with Clause IB.9.
1. Instructions to Bidders
  2. Bidding Data
  3. Form of Bid and Appendices to Bid
  4. Schedules to Bid
    - (i) Schedule A: Price Schedule for Goods offered from within the purchaser's country
    - (ii) Schedule B: Price Schedule for Goods offered from outside the purchaser's country
    - (iii) Schedule C: Delivery and Completion Schedule
    - (iv) Schedule D: Shipping Weights & Dimensions of Packages
    - (v) Schedule E: Deviations From Technical Provisions
    - (vi) Schedule F: Deviations From Contractual Conditions
    - (vii) Schedule G: Schedule of Technical Data
  5. Qualification Forms
  6. General Conditions of Contract (GCC), Part-I
  7. Particular Conditions of Contract (PCC), Part-II
  8. Standard Forms
    - (i) Form of Bid Security
    - (ii) Form of Performance Security
    - (iii) Form of Contract Agreement
    - (iv) Form of Advance Payment Security

## 9. Technical Provisions and Specifications

- 7.2 The bidders are expected to examine carefully the contents of all the above documents. Failure to comply with the requirements of bid submission will be at the Bidder's own risk. Pursuant to Clause IB.30, bids which are not substantially responsive to the requirements of the Bidding Documents will be rejected.

### **IB.8 Clarification of Bidding Documents**

- 8.1 Any prospective Bidder requiring any clarification (s) in respect of the Bidding Documents may notify the Purchaser in writing at the Purchaser's address indicated in the Invitation for Bids. The Purchaser will respond to any request for clarification which he receives earlier than the time, stated in the Bidding Data, prior to the deadline for submission of bids. Copies of the Purchaser's response will be forwarded to all purchasers of the Bidding Documents, including a description of the enquiry but without identifying its source.

### **IB.9 Amendment of Bidding Documents**

- 9.1 At any time prior to the deadline for submission of bids, the Purchaser may, for any reason, whether at his own initiative or in response to a clarification requested by a prospective Bidder, modify the Bidding Documents by issuing addendum.
- 9.2 Any addendum thus issued shall be part of the Bidding Documents pursuant to Sub-Clause 7.1 hereof and shall be communicated in writing to all purchasers of the Bidding Documents. Prospective Bidders shall acknowledge receipt of each addendum in writing to the Purchaser.
- 9.3 To afford prospective Bidders reasonable time in which to take an addendum into account in preparing their bids, the Purchaser may extend the deadline for submission of bids in accordance with Clause IB.24

## **C. PREPARATION OF BIDS**

### **IB.10 Language of Bid**

- 10.1 The bid as well as all correspondence and documents related to the bid exchanged by a bidder and the Purchaser shall be in the bid language stipulated in the Bidding Data and Particular Conditions of Contract. Supporting documents and printed literature furnished by the Bidders may be in any other language provided the same are accompanied by an accurate translation of the relevant parts in the bid language, in which case, for purposes of evaluation of the bid, the translation in bid language shall prevail.

### **IB.11 Documents Comprising the Bid**

- 11.1 Each Bidder shall:
- (a) Submit a written power of attorney authorizing the signatory of the bid to act for and on behalf of the Bidder;

- (b) update the information indicated and listed in the Bidding Data and previously submitted with the prequalification documents which as a minimum, would include the following application for prequalification, and continue to meet the minimum criteria set out in the:
- (i) Evidence of access to financial resources alongwith average annual turnover.
  - (ii) Financial predictions for the current year and the two following years including the effect of known commitments.
  - (iii) Supply commitments since prequalification.
  - (iv) Current litigation information.
  - (v) Availability of critical equipment.
- (c) Furnish a technical proposal taking into account the various Appendices to Bid specially the following:

Appendix-C to Bid	Method of Assuring Quality of Goods
Appendix-D to Bid	List of Quality Control/Laboratory Equipment
Appendix-E to Bid	List of Manufacturers / Subcontractors

and other pertinent information such as mobilization programme (under Appendix C to Bid) etc.

11.2 Bids submitted by a joint venture of two (2) or more firms shall comply with the following requirements:

- (a) The bid and in case of a successful bid, the Form of Contract Agreement shall be signed so as to be legally binding on all partners.
- (b) One of the joint venture partners shall be nominated as being in charge; and this authorization shall be evidenced by submitting a power of attorney signed by legally authorized signatories of all the joint venture partners.
- (c) The partner-in-charge shall always be duly authorized to deal with the Purchaser regarding all matters related with and/or incidental to the supply of Goods as per the terms and Conditions of Contract and in this regard to incur any and all liabilities, receive instructions, give binding undertakings and receive payments on behalf of the joint venture.
- (d) All partners of the joint venture shall at all times and under all circumstances be liable jointly and severally for the execution of the Contract in accordance with the Contract terms and a statement to this effect shall be included in the authorization mentioned under Sub-Para (b) above as well as in the Form of Bid and in the Form of Contract Agreement (in case of a successful bid).
- (e) A copy of the agreement entered into by the joint venture partners shall be submitted with the bid stating the conditions under which it will function, its period of duration, the persons authorized to represent and obligate it and which persons will be directly responsible for due performance of the Contract and can give valid receipts on behalf of the joint venture, the proportionate participation of the several firms forming the joint venture, and any other information necessary to permit a full appraisal of its functioning.

No amendments / modifications whatsoever in the joint venture agreement shall be agreed to between the joint venture partners without prior written consent of the Purchaser.

- 11.3 Bidders shall also submit proposals of supply and transportation methods and schedule, in sufficient detail to demonstrate the adequacy of the Bidders' proposals to meet the technical specifications and the completion time referred to in Sub-Clause 1.2 hereof.

#### **IB.12 Bid Prices**

- 12.1 The Bidder shall submit the Form of Bid using the form attached herewith. This form must be completed without any alterations to its format, and no substitutes shall be accepted. All blank spaces shall be filled in with the information requested.
- 12.2 The Bidder shall submit the Price Schedules for Goods, according to their origin as appropriate, using the forms furnished in Appendices to Bid along with Manufacturer's Authorization (on the format provided) in case the Bidder is not himself the manufacturer
- 12.3 Unless stated otherwise in the Bidding Documents (in Lots under Schedule B to Bid), the Contract shall be for the whole of the Goods as described in Sub-Clause 1.1 hereof, based on the unit rates and/or prices submitted by the bidder.
- 12.4 The Bidders shall fill in rates and prices for all items of the Goods described in the Price Schedules. Items against which no rate or price is entered by a bidder will not be paid for by the Purchaser when delivered and shall be deemed covered by rates and prices for other items in the Price Schedules.
- 12.5 All duties, taxes and other levies payable by the Contractor under the Contract, or for any other cause, as on the date 28 days prior to the deadline for submission of bids shall be included in the rates and prices and the total Bid Price submitted by a Bidder. Additional/reduced duties, taxes and levies due to subsequent additions or changes in legislation shall be dealt as per Clause 17 of the General Conditions of Contract.
- 12.6 The rates and prices quoted by the Bidders are subject to adjustment during the performance of the Contract in accordance with the provisions of Clause 15 of the General Conditions of Contract. The Bidders shall furnish the prescribed information for the price adjustment formulae if required under Sub-Clause 15.2 of General Conditions of Contract, and shall submit with their bids such other supporting information as required under the said Clause.

#### **IB.13 Currencies of Bid and Payment**

- 13.1 The unit rates and the prices shall be quoted by the Bidder entirely in Pak rupees. A Bidder expecting to incur expenditures in other currencies for

Goods supplied from outside the Purchaser's country (referred to as the "Foreign Currency Requirements") shall indicate the same in Appendix-B to Bid. The proportion of the Bid Price (excluding Provisional Sums) needed by him for the payment of such Foreign Currency Requirements either (i) entirely in the currency of the Bidder's home country or, (ii) at the Bidder's option, entirely in Pak rupees provided always that a Bidder expecting to incur expenditures in a currency or currencies other than those stated in (i) and (ii) above for a portion of the foreign currency requirements, and wishing to be paid accordingly, shall indicate the respective portions in his bid.

- 13.2 The rates of exchange to be used by the Bidder for currency conversion shall be the TT&OD Selling Rates published or authorized by the State Bank of Pakistan prevailing on the date 28 days prior to the deadline for submission of bids. For the purpose of payments, the exchange rates used in bid preparation shall apply for the duration of the Contract.

#### **IB.14 Documents Establishing the Eligibility of the Bidder**

To establish their eligibility in accordance with ITB 4, Bidders shall:

- (a) Provide the eligibility documents as per ITB Clause 3.
- (b) If the Bidder is an existing or intended JV in accordance with ITB 4.1 and 11.2, submit a copy of the JV Agreement, or a letter of intent to enter into such an Agreement. The respective document shall be signed by all legally authorized signatories of all the parties to the existing or intended JV, as appropriate.

#### **IB.15 Documents Establishing the Eligibility of the Goods**

- 15.1 To establish the eligibility of the Goods in accordance with ITB Clause 1-3, Bidders shall complete the country-of-origin declarations in the Price Schedule Forms, & Appendices to Bid.

#### **IB.16 Documents Establishing the Conformity of the Goods to the Bidding Document**

- 16.1 The bidder shall submit with the bid all the guaranteed characteristics, technical data and technical information specified herein, covering all material required by the Technical Provisions, all of which shall comply with the Bidding Documents and shall become a part thereof.
- 16.2 The documentary evidence may be in the form of literature, drawings or data, and shall consist of a detailed item-by-item description of the essential technical and performance characteristics of the Goods.
- 16.3 Standards for workmanship, process, material, and equipment, as well as references to brand names or catalogue numbers specified by the Purchaser in the Delivery and Completion Schedule, are intended to be descriptive only and not restrictive. The Bidder may offer other standards of quality,

brand names, and/or catalogue numbers, provided that it demonstrates, to the Purchaser's satisfaction, that the substitutions ensure substantial equivalence or are superior to those specified in Delivery and Completion Schedule of Supply.

### **IB.17 Documents Establishing the Qualification of the Bidder**

- 17.1 The documentary evidence of the Bidder's qualifications to perform the contract, if its bid is accepted, shall establish to the Purchaser's satisfaction that the Bidder meets each of the qualification criterion specified in Bidding Documents.
- 17.2 If so required in the Bidding Data, a Bidder that does not manufacture or produce the Goods it offers to supply shall submit the Manufacturer's Authorization using the appended form to demonstrate that it has been duly authorized by the manufacturer or producer of the Goods to supply these Goods in the Purchaser's country.
- 17.3 If so required in the Bidding Data, a Bidder that does not conduct business within the Purchaser's Country shall submit evidence that it will be represented by an Agent in the country equipped and able to carry out the Supplier's maintenance, repair and spare parts-stocking obligations prescribed in the Conditions of Contract and/or Technical Specifications.

### **IB.18 Bid Validity**

- 18.1 Bids shall remain valid for the period stipulated in the Bidding Data after the Date of Bid Opening specified in Clause IB.27.
- 18.2 In exceptional circumstances, prior to expiry of the original bid validity period, the Purchaser may request that the Bidders extend the period of validity for a specified additional period which shall in no case be more than the original bid validity period. The request and the responses thereto shall be made in writing. A Bidder may refuse the request without forfeiting his Bid Security. A Bidder agreeing to the request will not be required or permitted to modify his bid, but will be required to extend the validity of his Bid Security for the period of the extension, and in compliance with Clause IB.19 in all respects.

### **IB.19 Bid Security**

- 19.1 Each Bidder shall furnish, as part of his bid, a Bid Security in the amount stipulated in the Bidding Data in Pak Rupees or an equivalent amount in a freely convertible currency.
- 19.2 The Bid Security shall be, at the option of the Bidder, in the form of Deposit at Call or a Bank Guarantee issued by a Scheduled Bank in Pakistan or from a foreign bank duly counter guaranteed by a Scheduled Bank in Pakistan in favour of the Purchaser valid for a period 28 days beyond the Bid Validity date.

- 19.3 Any bid not accompanied by an acceptable Bid Security shall be rejected by the Purchaser as non-responsive.
- 19.4 The bid securities of unsuccessful Bidders will be returned as promptly as possible, but not later than 28 days after the expiration of the period of Bid Validity.
- 19.5 The Bid Security of the successful Bidder will be returned when the Bidder has furnished the required Performance Security and signed the Contract Agreement.
- 19.6 The Bid Security may be forfeited:
- (a) If the Bidder withdraws his bid except as provided in Sub-Clause 26.1.
  - (b) If the Bidder does not accept the correction of his Bid Price pursuant to Sub-Clause 31.2 hereof.
  - (c) In the case of successful Bidder, if he fails within the specified time limit to:
    - (i) Furnish the required Performance Security; or
    - (ii) Sign the Contract Agreement.

#### **IB.20 Alternate Proposals by Bidder**

- 20.1 Should any Bidder consider that he can offer any advantages to the Purchaser by a modification to the designs, specifications or other conditions, he may, in addition to his bid to be submitted in strict compliance with the Bidding Documents, submit any Alternate Proposal(s) containing (a) relevant design calculations; (b) technical specifications; (c) proposed manufacturing methodology; and (d) any other relevant details / conditions, provided always that the total sum entered on the Form of Bid shall be that which represents complete compliance with the Bidding Documents.
- 20.2 Alternate Proposal(s), if any, of the lowest evaluated responsive Bidder only may be considered by the Purchaser as the basis for the award of Contract to such Bidder.

#### **IB.21 Pre-Bid Meeting**

- 21.1 The Purchaser may, on his own motion or at the request of any prospective Bidder(s), hold a pre-bid meeting to clarify issues and to answer any questions on matters related to the Bidding Documents. The date, time and venue of pre-bid meeting, if convened, is as stipulated in the Bidding Data. All prospective Bidders or their authorized representatives shall be invited to attend such a pre-bid meeting.
- 21.2 The Bidders are requested to submit questions, if any, in writing so as to reach the Purchaser not later than seven (7) days before the proposed pre-bid meeting.

- 21.3 Minutes of the pre-bid meeting, including the text of the questions raised and the replies given, will be transmitted without delay to all purchasers of the Bidding Documents. Any modification of the Bidding Documents listed in Sub-Clause 7.1 hereof which may become necessary as a result of the pre-bid meeting shall be made by the Purchaser exclusively through the issue of an Addendum pursuant to Clause IB.9 and not through the minutes of the pre-bid meeting.
- 21.4 Absence at the pre-bid meeting will not be a cause for disqualification of a Bidder.

## **IB.22 Format and Signing of Bid**

- 22.1 Bidders are particularly directed that the amount entered on the Form of Bid shall be for performing the Contract strictly in accordance with the Bidding Documents.
- 22.2 All Appendices and Schedules to Bid are to be properly completed and signed.
- 22.3 No alteration is to be not made in the Form of Bid nor in the Appendices and Schedules thereto except in filling up the blanks as directed. If any such alterations be made or if these instructions be not fully complied with, the bid may be rejected.
- 22.4 Each Bidder shall prepare by filling out the forms completely and without alterations one (1) original and number of copies, specified in the Bidding Data, of the documents comprising the bid as described in Clause IB.7 and clearly mark them "ORIGINAL" and "COPY" as appropriate. In the event of discrepancy between them, the original shall prevail.
- 22.5 The original and all copies of the bid shall be typed or written in indelible ink (in the case of copies, Photostats are also acceptable) and shall be signed by a person or persons duly authorized to sign on behalf of the Bidder pursuant to Sub- Clauses 11.1(a) and 11.2 hereof. All pages of the bid shall be initialled and stamped by the person or persons signing the bid.
- 22.6 The bid shall contain no alterations, omissions or additions, except to comply with instructions issued by the Purchaser, or as are necessary to correct errors made by the Bidder, in which case such corrections shall be initialled by the person or persons signing the bid.
- 22.7 Bidders shall indicate in the space provided in the Form of Bid their full and proper addresses at which notices may be legally served on them and to which all correspondence in connection with their bids and the Contract is to be sent.
- 22.8 Bidders should retain a copy of the Bidding Documents as their file copy.

## **D. SUBMISSION OF BIDS**

**IB.23 Sealing and Marking of Bids**

- 23.1 Each Bidder shall submit his bid as under:
- (a) ORIGINAL and each copy of the Bid shall be separately sealed and put in separate envelopes and marked as such.
  - (b) The envelopes containing the ORIGINAL and copies will be put in one sealed envelope and addressed/identified as given in Sub- Clause 23.2 hereof.
- 23.2 The inner and outer envelopes shall:
- (a) Be addressed to the Purchaser at the address provided in the Bidding Data;
  - (b) Bear the name and identification number of the Contract as defined in the Bidding Data; and
  - (c) Provide a warning not to open before the time and date for bid opening, as specified in the Bidding Data.
- 23.3 In addition to the identification required in Sub- Clause 23.2 hereof, the inner envelope shall indicate the name and address of the Bidder to enable the bid to be returned unopened in case it is declared “late” pursuant to Clause IB.25
- 23.4 If the outer envelope is not sealed and marked as above, the Purchaser will assume no responsibility for the misplacement or premature opening of the Bid.

**IB.24 Deadline for Submission of Bids**

- 24.1
- (a) Bids must be received by the Purchaser at the address specified no later than the time and date stipulated in the Bidding Data.
  - (b) Bids with charges payable will not be accepted, nor will arrangements be undertaken to collect the bids from any delivery point other than that specified above. Bidders shall bear all expenses incurred in the preparation and delivery of bids. No claims will be entertained for refund of such expenses.
  - (c) Where delivery of a bid is by mail and the Bidder wishes to receive an acknowledgment of receipt of such bid, he shall make a request for such acknowledgment in a separate letter attached to but not included in the sealed bid package.
  - (d) Upon request, acknowledgment of receipt of bids will be provided to those making delivery in person or by messenger.
- 24.2 The Purchaser may, at his discretion, extend the deadline for submission of bids by issuing an amendment in accordance with Clause IB.9, in which case

all rights and obligations of the Purchaser and the Bidders previously subject to the original deadline will thereafter be subject to the deadline as extended.

### **IB.25 Late Bids**

- 25.1 (a) Any bid received by the Purchaser after the deadline for submission of bids prescribed in Clause IB.24 will be returned unopened to such bidder.
- (b) Delays in the mail, delays of person in transit, or delivery of a bid to the wrong office shall not be accepted as an excuse for failure to deliver a bid at the proper place and time. It shall be the Bidder's responsibility to determine the manner in which timely delivery of his bid will be accomplished either in person, by messenger or by mail.

### **IB.26 Modification, Substitution and Withdrawal of Bids**

- 26.1 Any Bidder may modify, substitute or withdraw his bid after bid submission provided that the modification, substitution or written notice of withdrawal is received by the Purchaser prior to the deadline for submission of bids.
- 26.2 The modification, substitution, or notice for withdrawal of any bid shall be prepared, sealed, marked and delivered in accordance with the provisions of Clause IB.23 with the outer and inner envelopes additionally marked "MODIFICATION", "SUBSTITUTION" or "WITHDRAWAL" as appropriate.
- 26.3 No bid may be modified by a Bidder after the deadline for submission of bids except in accordance with Sub-Clauses 26.1 and 31.2.
- 26.4 Withdrawal of a bid during the interval between the deadline for submission of bids and the expiration of the period of bid validity specified in the Form of Bid may result in forfeiture of the Bid Security in pursuance to Clause IB.19.

## **E. BID OPENING AND EVALUATION**

### **IB.27 Bid Opening**

- 27.1 The Purchaser will open the bids, including withdrawals, substitution and modifications made pursuant to Clause IB.26, in the presence of Bidders' representatives who choose to attend, at the time, date and location stipulated in the Bidding Data. The Bidders' representatives who are present shall sign a register evidencing their attendance.
- 27.2 Envelopes marked "MODIFICATION", "SUBSTITUTION" or "WITHDRAWAL" shall be opened and read out first. Bids for which an acceptable notice of withdrawal has been submitted pursuant to Clause IB.26 shall not be opened.
- 27.3 The Bidder's name, total Bid Price and price of any Alternate Proposal(s),

any discounts, bid modifications, substitution and withdrawals, the presence or absence of Bid Security, and such other details as the Purchaser may consider appropriate, will be announced by the Purchaser at the opening of bids.

- 27.4 Purchaser shall prepare minutes of the bid opening, including the information disclosed to those present in accordance with the Sub-Clause 27.3.

### **IB.28 Process to be Confidential**

- 28.1 Information relating to the examination, clarification, evaluation and comparison of bid and recommendations for the award of a Contract shall not be disclosed to Bidders or any other person not officially concerned with such process before the announcement of bid evaluation report which shall be done at least ten (10) days prior to issue of Letter of Acceptance. The announcement to all Bidders will include table(s) comprising read out prices, discounted prices, price adjustments made, final evaluated prices and recommendations against all the bids evaluated. Any effort by a Bidder to influence the Purchaser's processing of bids or award decisions may result in the rejection of such Bidder's bid. Whereas any Bidder feeling aggrieved may lodge a written complaint not later than fifteen (15) days after the announcement of the bid evaluation report; however mere fact of lodging a complaint shall not warrant suspension of the procurement process.

### **IB.29 Clarification of Bids**

- 29.1 To assist in the examination, evaluation and comparison of bids, the Purchaser may, at his discretion, ask any Bidder for clarification of his bid, including breakdowns of unit rates. The request for clarification and the response shall be in writing but no change in the price or substance of the bid shall be sought, offered or permitted except as required to confirm the correction of arithmetic errors discovered by the Purchaser in the evaluation of the bids in accordance with Clause IB.32.

### **IB.30 Examination of Bids and Determination of Responsiveness**

- 30.1 Prior to the detailed evaluation of bids, the Purchaser will determine whether each bid is substantially responsive to the requirements of the Bidding Documents.
- 30.2 A substantially responsive bid is one which (i) meets the eligibility criteria; (ii) has been properly signed; (iii) is accompanied by the required Bid Security; and (iv) conforms to all the terms, conditions and specifications of the Bidding Documents, without material deviation or reservation. A material deviation or reservation is one (i) which affect in any substantial way the scope, quality or performance of the Goods; (ii) which limits in any substantial way, inconsistent with the Bidding Documents, the Purchaser's rights or the Bidder's obligations under the Contract; or (iii)

adoption/rectification whereof would affect unfairly the competitive position of other Bidders presenting substantially responsive bids.

- 30.3 If a bid is not substantially responsive, it will be rejected by the Purchaser, and may not subsequently be made responsive by correction or withdrawal of the non-conforming deviation or reservation.

### **IB.31 Correction of Errors**

- 31.1 Bids determined to be substantially responsive will be checked by the Purchaser for any arithmetic errors. Errors will be corrected by the Purchaser as follows:
- (a) Where there is a discrepancy between the amounts in figures and in words, the amount in words will govern; and
  - (b) Where there is a discrepancy between the unit rate and the line item total resulting from multiplying the unit rate by the quantity, the unit rate as quoted will govern, unless in the opinion of the Purchaser there is an obviously gross misplacement of the decimal point in the unit rate, in which case the line item total as quoted will govern and the unit rate will be corrected.
- 31.2 The amount stated in the Form of Bid will be adjusted by the Purchaser in accordance with the above procedure for the correction of errors and with the concurrence of the Bidder, shall be considered as binding upon the Bidder. If the Bidder does not accept the corrected Bid Price, his Bid will be rejected, and the Bid Security shall be forfeited in accordance with Sub-Clause 19.6(b) hereof.

### **IB.32 Evaluation and Comparison of Bids**

- 32.1 The Purchaser will evaluate and compare only the Bids determined to be substantially responsive in accordance with Clause IB.30.
- 32.2 In evaluating the Bids, the Purchaser will determine for each Bid the evaluated Bid Price by adjusting the Bid Price as follows:
- (a) Making any correction for errors pursuant to Clause IB.31;
  - (b) Excluding Provisional Sums and the provision, if any, for contingencies; and
  - (c) Making an appropriate adjustment for any other acceptable variation or deviation from specification or performance criteria
- 32.3 The estimated effect of the price adjustment provisions of the Conditions of Contract, applied over the period of execution of the Contract, shall not be taken into account in Bid evaluation.

- 32.4 If the Bid of the successful Bidder is seriously unbalanced in relation to the Purchaser's estimate of the cost of Goods to be delivered under the Contract, the Purchaser may require the Bidder to produce detailed price analyses for any or all items of the Price Schedules to demonstrate the internal consistency of those prices with the manufacturing methodology and schedule proposed. After evaluation of the price analyses, the Purchaser may require that the amount of the Performance Security set forth in Clause IB.37 be increased at the expense of the successful Bidder to a level sufficient to protect the Purchaser against financial loss in the event of default of the successful bidder under the Contract.

### **IB.33 Post Qualification of the Bidder**

- 33.1 The Purchaser shall determine to its satisfaction whether the Bidder that is selected as having submitted the lowest evaluated and substantially responsive Bid is qualified to perform the Contract satisfactorily.
- 33.2 The determination shall be based upon an examination of the documentary evidence of the Bidder's qualifications submitted by the Bidder.
- 33.3 An affirmative determination shall be a prerequisite for award of the Contract to the Bidder. A negative determination shall result in disqualification of the Bid, in which event the Purchaser shall proceed to the next lowest evaluated bid to make a similar determination of that Bidder's capabilities to perform satisfactorily.

## **F. AWARD OF CONTRACT**

### **IB.34 Award**

- 34.1 Subject to Clauses IB.35 and IB.39, the Purchaser will award the Contract to the Bidder whose bid has been determined to be substantially responsive to the Bidding Documents and who has offered the lowest evaluated Bid Price, provided that such Bidder has been determined to be eligible in accordance with the provisions of Clause IB.3 and qualify pursuant to Sub-Clause IB 33.2.
- 34.2 The Purchaser, at any stage of the bid evaluation, having credible reasons for or prima facie evidence of any defect in supplier's or contractor's capacities, may require the suppliers or contractors to provide information concerning their professional, technical, financial, legal or managerial competence whether already pre-qualified or not:

Provided that such qualification shall only be laid down after recording reasons therefor in writing. They shall form part of the records of that bid evaluation report.

### **IB.35 Purchaser's Right to accept any Bid and to reject any or all Bids**

- 35.1 Notwithstanding Clause IB.34, the Purchaser reserves the right to accept or reject any Bid, and to annul the bidding process and reject all bids, at any

time prior to award of Contract, without thereby incurring any liability to the affected Bidders or any obligation except that the grounds for rejection of all bids shall upon request be communicated to any Bidder who submitted a bid, without justification of grounds. Rejection of all bids shall be notified to all Bidders promptly.

- 35.2 At the time the Contract is awarded, the Purchaser reserves the right to increase or decrease the quantity of Goods originally specified in Delivery and Completion Schedules, provided this does not exceed the percentages indicated in the Bidding Data, and without any change in the unit prices or other terms and conditions of the Bid and the Bidding Document.

### **IB.36 Notification of Award**

- 36.1 Prior to expiration of the period of bid validity prescribed by the Purchaser, the Purchaser will notify the successful Bidder in writing (“Letter of Acceptance”) that his Bid has been accepted. This letter shall name the sum which the Purchaser will pay the Contractor in consideration of the delivery of Goods by the Contractor as prescribed by the Contract (hereinafter and in the Conditions of Contract called the “Contract Price”).
- 36.2 No Negotiation with the Bidder having evaluated as lowest responsive or any other Bidder shall be permitted, however, Purchaser may seek clarification in writing to clarify any item in the bid evaluation report; and response of the Bidder shall also be in writing.
- 36.3 The notification of award and its acceptance by the Bidder will constitute the formation of the Contract, binding the Purchaser and the Bidder till signing of the formal Contract Agreement.
- 36.4 Upon furnishing by the successful Bidder of a Performance Security, the Purchaser will promptly notify the other Bidders that their Bids have been unsuccessful and return their bid securities.

### **IB.37 Performance Security**

- 37.1 The successful Bidder shall furnish to the Purchaser a Performance Security in the form and the amount stipulated in the Bidding Data and the Conditions of Contract within a period of 28 days after the receipt of Letter of Acceptance.
- 37.2 Failure of the successful Bidder to comply with the requirements of Sub-Clause IB.37.1 or Clauses IB.38 or IB.40 shall constitute sufficient grounds for the annulment of the award and forfeiture of the Bid Security.

### **IB.38 Signing of Contract Agreement**

- 38.1 Within 14 days from the date of furnishing of acceptable Performance Security under the Conditions of Contract, the Purchaser will send the

successful Bidder the Contract Agreement in the form provided in the Bidding Documents, incorporating all agreements between the parties.

- 38.2 The formal Agreement between the Purchaser and the successful Bidder shall be executed within 14 days of the receipt of the Contract Agreement by the successful Bidder from the Purchaser.

### **IB.39 General Performance of the Bidders**

- 39.1 The Purchaser reserves the right to obtain information regarding performance of the bidders on their previously awarded contracts. The Purchaser may in case of consistent poor performance of any Bidder as reported by the purchasers of the previously awarded contracts, interalia, reject his bid and proceed in accordance with Rule 19 of the Public Procurement Rules 2004 to take such action as may be deemed appropriate under the circumstances of the case including black listing of such Bidder and debarring him from participation in future bidding for supply of Goods.

### **IB.40 Integrity Pact**

- 40.1 The Bidder shall sign and stamp the Integrity Pact provided at Appendix-G to Bid in the Bidding Documents for all Federal Government procurement contracts exceeding Rupees ten million. Failure to provide such Integrity Pact shall make the bidder non-responsive.

### **IB.41 Instructions not Part of Contract**

- 41.1 Bids shall be prepared and submitted in accordance with these Instructions which are provided to assist Bidders in preparing their bids, and do not constitute part of the Bid or the Contract Documents.

### **IB.42 Margin of Preference**

- 42.1 Unless otherwise specified in the Bidding Data, no margin of preference shall apply. Domestic Preference shall be applicable in case of International Competitive Bidding as per policy of the government, in accordance with the procedure given in the Bidding Data.

**SECTION-II**  
**BID DATA SHEET**

## **BID DATA SHEET**

This Section includes provisions that are specific to each procurement and that supplement Section I, Instructions to Bidders. Whenever there is a conflict, the provisions herein shall prevail over those in Section I.

<b>IB 1.1</b>	<p>Name and address of the Purchaser</p> <p>Name: Chief Engineer Asset Management North NGC Multan  Address: Chief Engineer, Asset Management North NGC  GSO House, Sher Shah Road, Cantt. Multan  Telephone No. 92-61-9200515  Fax No. 92-61-9200516</p> <p>The name of the NCB is: CE-AM-NGC-MN-03-2025-26 “Procurement of Liveries/Uniform item for Security Staff (Asset Management) North Region NGC Multan”.</p> <p>The number and identification of lot comprising this NCB is: One (01)  Name: Procurement of Liveries/Uniform item for Security Staff (Asset Management) North Region NGC Multan.</p> <p>The Bidders are required to quote for one complete Lot. Partial quotation shall be liable of rejection.</p> <p>Goods supplied under this Contract will be based on FCS basis transported by the contractor from Ex-Works Pakistan to C type store Multan at its own cost.</p>
<b>IB 1.7</b>	<p>The Bidding is open to National Competitive Bidding (NCB) through Single Stage Two Envelope (SSTE) procedure.</p>
<b>IB 2.1</b>	<p>Financing shall be from NGC’s own resources.</p>
<b>IB 3.1 (b)</b>	<p>Delete IB 3.1 (b) and replace it with the following:</p> <p>The invitation for Bids is open to all Bidders with qualification as described below:</p> <ol style="list-style-type: none"> <li>1. The Bidder shall be a manufacturer or Supplier legally registered for at least five years. A copy of legal registration certificate shall be submitted along with the Bid.</li> </ol>

**2. Manufacturer/Supplier Experience Criteria**

- i. The supplier must have authorized distribution rights from the manufacturer.
- ii. The Manufacturer/Supplier must have completed 03 similar contracts of supply within last five years. The bidder must submit with the bid the supply record for the last five years. (Information to be submitted in QF-2 & QF-4, Section-V).
- iii. For verification of the past performance, the seller shall submit the copies of the contract agreement for the goods indicated in the supply record of the Bidder pertaining to the specified and comparable equipment.
- iv. The bidder must be a tax payer; tax returns for the last three years must be submitted with the bid.

**3. Operational/ Quality Assurance Criteria**

- i. Similar/offered goods supplied by the Bidder should have been in satisfactory condition for a continuous period of at least one year on the date of Bid opening.
- ii. In above context, the bidder must also submit with the bid the copies of contract agreements and completion certificates.

**4. Supply Capacity**

The manufacturer/bidder shall provide the following information with the Bid to establish its capacity/capability to execute the order.

- a. Manufacturing/Supply Capacity
- b. Orders in hand
- c. Expected orders in pipe line
- d. Implementation schedule of the orders in hand

The manufacturing/supply capacity of the Bidder/manufacturer should be at least equal to of orders in hand, expected orders in pipeline and this order (if placed on it).

5. Samples of offered material are compulsory along-with the bid. Without sample the bid will be rejected. The samples provided will be non-returnable.

**6. Financial Criteria**

The Purchaser will take into account the following criteria to verify the financial qualification of the bidder

- i. The audited financial “standalone” statements (Balance Sheet, Profit & Loss A/c and Cash Flow statement) audited by Chartered Accountant for the last three (3) years have to be submitted by bidder, which shall be evaluated. The bidder’s financial statements for the last three years of the audited accounts should show that it has positive “NET WORTH” calculated as a difference between total assets and total liabilities (information to be submitted in QF-7, Section-V)
- ii. The bidder’s Income & expenditure / profit and loss account should show minimum average annual turnover for the last three years not less than the amount quoted below (Information to be submitted in QF-8, Section-V).

Sr. No	Description	Minimum Average Annual Turnover (ATT) (PKR)
I.	Liveries/Uniform item for Security Staff	3.024 Million

- iii. The bidder must demonstrate access to, or availability of, financial resources such as liquid assets, unencumbered real assets, lines of credit, and other financial means, other than any contractual advance payments to meet the minimum cash-flow requirement for each lot as mentioned below for evaluation purpose (Information to be submitted in QF 9 & 10, Section-V).

Sr. No.	Description	Minimum Required Cash Flow (PKR)
I.	Liveries/Uniform item for Security Staff	3.024 Million

**7. Litigation History**

Bidders are requested to submit details of all litigation, arbitration and other claims whether pending, threatened or resolved in the last five years. The Purchaser may disqualify Bidder’s in the event that the total amount of pending or threatened litigation, arbitration or other claims represents twenty five percent (25%) of the Bidder’s net worth. Details in this regard should be submitted in the prescribed format given in QF-11, Section-V.

	<p>8. The Bidder shall be registered with Income Tax and Sales Tax Departments and shall be on Active Taxpayers List of the Federal Board of Revenue.</p> <p>9. The Bidder/manufacturer shall not be blacklisted by any agency i.e. NGC/WAPDA/DISCOs/any Government/Public department/Donor Agencies, etc. The Bidder/manufacturer should provide details of black listing, if any. An affidavit is to be provided that the Bidder is not black listed by any agency i.e. NGC/WAPDA/DISCOs/any Government/Public department/Donor Agencies at the time of submission of bids.</p> <p>The Qualification of the Bidders will be based on meeting the minimum pass/fail criteria as demonstrated by the Bidders' responses in the corresponding schedules and forms.</p> <p>The above stated requirements are a minimum and the Purchaser reserves the right to request for any additional information. The Purchaser also reserves the right to reject the proposal of any Bidder, if in the opinion of the Purchaser the qualification details are incomplete, ambiguous or the Bidder is found not qualified to satisfactorily perform the contract.</p>
<b>IB 7.1</b>	There is only one volume in this NCB.
<b>IB 7.2</b>	<p>The Bidders should ensure that they have received the Bidding Documents including Addenda (if any) complete in all respects. The Employer accepts no responsibility for any Bidder lacking a complete set of Bidding Documents including Addenda (if any). The complete Bidding Document including Addenda (if any) will also be available on Employer's website i.e. <a href="http://www.ntdc.com.pk">www.ntdc.com.pk</a> and on e-PADS.</p> <p>After the Award of Contract, the Supplier/Contractor will provide copies of 15 Nos. of Contract Agreement complete in all respect within ten (10) days from the signing of Contract Agreement.</p>

<p><b>IB 8.1</b></p>	<p>The Sub-Clause 8.1 is amended to the following extent:</p> <p>No request for clarification will be entertained which will be received later than 07 days prior to the date fixed for submission of Bids. The Purchaser's response will be made not later than 03 days prior to the date fixed for submission of Bids. Moreover, the bidders may also submit their request for clarification through e-PADS.</p> <p>Further, the mere request for clarification from the bidders shall not be a ground for seeking extension in the deadline for submission of Bids</p> <p>The address for clarification of Bidding Documents is:-</p> <p>office of Chief Engineer (A.M) North,  NGC Multan GSO House, Sher Shah Road, Cantt. Multan  Telephone No. 92-61-9200515  Fax No. 92-61-9200516</p>
<p><b>IB 10.1</b></p>	<p>The Bid with all accompanying documents and all communications in relation to or concerning the Bidding Process shall be in <b>English</b> language and strictly on the forms provided in the Bidding Documents. In case any of these Documents is in another language, it must be accompanied by an accurate translation of the relevant passages in English, in which case, for all purposes of interpretation of the Bid, the translation in English shall prevail. Any portions of Bids that are not in English may not be evaluated. Failure to comply with this may disqualify a Bid.</p>

<b>IB 11.1</b>	<p>Delete the text of this Sub-Clause and substitute with the following:</p> <p>The Bidder shall submit the bid through e-PADS only in 2 separate pdf files, one to be referred as “Technical Bid” and the other to be referred as “Price Bid” comprising the following documents in the respective pdf files, <b>however, Bid Security is required to be submitted in original before bids submission deadline:</b></p> <p><b>I. Technical Bid</b></p> <ol style="list-style-type: none"> <li>a) Duly filled-in Form of Technical Bid along with Schedules to Bid other than those mentioned in the Price Bid.</li> <li>b) Covering Letter</li> <li>c) Receipt of tender document cost</li> <li>d) Undertaking by the bidder in respect of submission of required Bid Security as per <b>Appendix-A</b> to Bidding Data.</li> <li>e) Complete specifications (schedule of technical data) with supporting documents, brochures of the offered items. If specifications/model do not meet the tender requirements, offered material shall not be entertained.</li> <li>f) Copies of original documents defining the constitution or legal status, place of registration and principal place of business. A list showing the location of head office along with those of branch offices.</li> <li>g) Business Registration License along with copies of documents defining the constitution or legal status, place of registration and principal place of business.</li> <li>h) Written Power of Attorney, duly notarized, authorizing the signatory of the bid to act for and on behalf of the Bidder</li> <li>i) Authority to seek reference from the Bidder’s banks.</li> <li>j) Documentary evidence in support of the qualifying requirement as stipulated in IB 3 above.</li> <li>k) A list of clients to whom the bidder has done or been doing business during last 2 years along with the Names, Addresses and Phone Numbers</li> <li>l) Delivery Schedule on the prescribed format</li> <li>m) Undertaking of Acceptance of and Compliance with the SOP for Blacklisting of Contractors <b>Appendix -B</b> to Bidding Data</li> </ol> <p><b>II. Price Bid</b></p> <ol style="list-style-type: none"> <li>a) Duly filled-in Form of Price Bid with following Schedules to Bid: <ol style="list-style-type: none"> <li>i) Schedule-A to Bid Price Schedule for Goods offered from within the Purchaser’s Country</li> </ol> </li> </ol>
<b>IB 11.1(c)</b>	This clause is not applicable in this tender.
<b>IB 12.6</b>	The prices quoted by the Bidder shall be <b>Firm &amp; Final</b> and shall not be adjustable.

<b>IB 13.1</b>	The Bidder shall quote prices in Pak Rupees.
<b>IB 16.1</b>	To establish the conformity of the Goods to the Bidding documents, the Bidder shall furnish a detailed description of the essential technical and performance characteristics of the equipment as per relevant technical specifications mentioned in Section 9 and any other information, documents required by the Bidding documents or the Purchaser.
<b>IB 16.2</b>	<p>The Bidder shall also furnish a statement of deviations and exceptions to the provisions of the Technical Specifications as per <b>Schedule-F</b>.</p> <p>No deviations or exceptions to the provisions of the Technical Specifications shall be allowed if not mentioned in the Schedule of deviation. Any misrepresentation, misstatement in this regard may result in rejection of the Bid and termination of the contract in case of award.</p>
<b>IB 17.2</b>	The Bidder must submit the manufacturer's authorization, using the form provided in the Bidding document showing that the Bidder has been duly authorized by the manufacturer of the related Equipment/Goods to supply that item. However, this condition does not apply on the bid submitted by the manufacturer directly.
<b>IB 18.1</b>	The period for validation of Bid will be minimum 120 days after the date of Bid opening. A Bid valid for short period shall be liable of rejection.
<b>IB 19.1</b>	All Bids must be accompanied by a Bid Security of not less than PKR 150,000/-
<b>IB 19.2</b>	<ul style="list-style-type: none"> <li>i. A bank guarantee shall be on a non-judicial stamp paper of value Rs.500/- in the format provided in bidding document by any reputable scheduled bank of Pakistan or a reputable foreign bank underwritten by a scheduled bank of Pakistan valid for a period 28 days beyond the Bid Validity date.</li> <li>ii. OR A cash deposit receipt issued by any reputable scheduled bank of Pakistan valid for a period 28 days beyond the Bid Validity date.</li> <li>iii. The Bid security shall be drawn in the favor of "<b>Chief Engineer WAPDA NTDC</b>".</li> </ul>
<b>IB 20.</b>	Alternative proposals are not allowed.
<b>IB 21.1</b>	<p>Pre-Bid meeting will take place on  <b>05-May-2026 03:00 PM</b>  Office of Chief Engineer Asset Management North NGC, GSO House, Sher Shah Road, Cantt. Multan.</p>
<b>IB 22.4</b>	<p>Bid Security shall be submitted to  office of Chief Engineer (A.M) North, NGC Multan GSO House, Sher Shah Road, Cantt. Multan.</p> <p>Bid must be received by the Employer through e-PADS only before the bid submission deadline, however, Bid Security is required to be submitted in original (in Hard Copy) before bids submission deadline at above mentioned address.</p>

	Further, the Procuring Agency shall reject the bid, if the bid submitted through e-PADS found corrupt, unreadable or contains virus.
<b>IB 22.5</b>	<p>The letter of authorization shall be written Power of Attorney accompanying the Bid. The Name and Position held by each person signing the authorization must be typed or printed below the signature. The Bidder's name stated on the proposal shall be the exact legal name of the firm.</p> <p>A Bid by a person who affixes to his signature the word "President", "Managing Director", "Secretary", "Agent" or other designation without disclosing his principal will be rejected.</p> <p>All pages of the Bid where entries or amendments have been made shall be initialed by the authorized person or persons signing the Bid.</p> <p>Bid not conforming to the above requirements of signing shall be disqualified.</p>
<b>D.</b>	<b>SUBMISSION OF BID</b>
<b>IB 23.2 (a)</b>	The Bidders Shall submit their bids through EPADS.
<b>IB 23.2 (b)</b>	<p>Name of the Project:</p> <p>"Procurement of Liveries/Uniform item for Security Staff (Asset Management) North Region NGC Multan"</p> <p>Identification No.: CE-AM-NGC-MN-03-2025-26</p>
<b>IB 24.1 (a)</b>	<p>Deadline for Submission of Bid:</p> <p>Date: <b>11<sup>th</sup> May, 2026</b></p> <p>Time: 14:30 HRS</p>
<b>IB 24.1 (b)</b>	The Bidders Shall submit their bids through EPADS.
<b>E.</b>	<b>BID OPENING AND EVALUATION</b>
<b>IB.27</b>	<p><b>Bid Opening</b></p> <p>Sub-Clause IB.27 is substituted by the following:</p>
<b>IB 27.1</b>	<p>The Bid opening shall take place at:</p> <p>Office of Chief Engineer (A.M) North, NGC Multan GSO House, Sher Shah Road, Cantt. Multan.</p> <p>Date: <b>11<sup>th</sup> May, 2026</b></p> <p>Time: 15:00 HRS</p> <p>Further the attendance will also be marked through e-PADS.</p>

<b>IB27.2</b>	The Price Bids will remain unopened and will be held in custody of the Purchaser until the time of opening of the Price Bids. The date, time, and location of the opening of Price Bids will be advised in writing by the Purchaser. If the Price Bid is submitted unsealed or found unsealed inside the envelope of Technical Bid, the Purchaser shall reject the entire Bid and record at the time of opening of the Technical Bids.
<b>IB27.3</b>	<p>All other envelopes holding the Technical Bids, except the Bids rejected pursuant to Sub-Clause IB. 27.2, shall be opened one at a time, and the following read out and recorded</p> <ul style="list-style-type: none"> <li>(a) the name of the Bidder;</li> <li>(b) whether there is a modification or substitution;</li> <li>(c) the presence of an undertaking by the Bidder in respect of submission of required Bid Security; and</li> <li>(d) any other details as the Purchaser may consider appropriate.</li> </ul> <p>Only Technical Bids and alternative Technical Bids (if allowed under Sub-Clause IB. 20 hereof) read out and recorded at bid opening shall be considered for evaluation. Unless otherwise specified in the BDS, the Form of Technical Bid is to be initialed by the nominated representatives of the Purchaser attending the bid opening. No Bid shall be rejected at the opening of Technical Bids except for late bids, in accordance with IB.25.1.</p>
<b>IB 28.</b>	<p>Process to be Confidential</p> <p>Add the following new Sub-Clause after Sub-Clause IB 28.1:</p>
<b>IB 28.2</b>	Bidders and their respective agents, manufacturers/suppliers, representatives and anyone else on behalf of the Bidder will not communicate or attempt to communicate directly or indirectly with the Purchaser, including any employees, directors, officers, agents or representatives of any of them during any part of the Competitive Bidding Process, except as expressly directed or permitted by the Purchaser. Bidders will also not engage in any form of political or other lobbying whatsoever with respect to their Bids, or otherwise attempt to influence the outcome of the Competitive Bidding Process. In the event of any such communications or lobbying, Purchaser may at any time reject any Bid by that Bidder without further consideration.

<b>IB 29.1</b>	<ul style="list-style-type: none"> <li>i. The Purchaser's request for such clarifications, additional information or modifications may be made for information that has been partially or completely omitted from a Bid. However, the Purchaser does not have an obligation to request any additional information or clarification with respect to missing or deficient information in a Bid.</li> <li>ii. If the Purchaser request clarifications, additional information or modifications from a Bidder, such requests will be forwarded to the applicable Bidder in writing. The Purchaser may consider and take into account any and all additional information or clarification provided by a Bidder in response to such requests in the same manner and to the same extent as if that information or clarification was part of such Bidder's original Bid. However, the Purchaser will not consider any information provided after the Closing Time that is not in response to a request.</li> </ul>
<b>IB 30.1</b>	<ul style="list-style-type: none"> <li>i. The Purchaser may refuse to consider, remove from the evaluation process entirely and to reject out right any Bid that the Purchaser determines is materially incomplete, obscure or irregular, that contains exceptions or variations not acceptable to the Purchaser or that omits any material information required to be submitted by the Bidding Documents.</li> <li>ii. The evaluation of various experience criteria shall be done on the basis of certificates (issued by Order Placing Authority clearly indicating the date of issue) submitted by the Bidder for which responsibility to furnish necessary documentary proof rests on participating Bidder. It is not obligatory on the part of the Purchaser to seek any clarification or ask for submission of any certificate towards experience in case required documents are not enclosed with the Bids. The Purchaser will not be responsible if the Bid is considered non-responsive and rejected in the absence of such certificates.</li> </ul>
<b>IB 30.2</b>	The Purchaser reserves the right to waive minor deviations if they do not materially affect the capability of the Bidder to perform the contract.

<b>IB 30.3</b>	<p>If a Bid in the Purchaser’s opinion is materially incomplete, obscure or irregular, contains exceptions or variations not acceptable to Purchaser or omits any material information required to be submitted by the Bidding Documents, then the Purchaser (taking into account the number of compliant Bids that were actually received) may waive such non-conformance with the requirements of this Bidding Documents on such terms and conditions as the Purchaser may consider appropriate, even if any such non-conformance or failure to comply with the requirements of this Bidding Documents would otherwise render such Bid null and void. The decision of the Purchaser in this matter shall be final and binding on the Bidders.</p> <p>The purchaser is not bound to accept the lowest offer not fulfilling the requisite criteria. The reasons for rejecting the lowest or any other offer shall not necessarily be communicated.</p>
<b>IB 32.1</b>	<p>The Purchaser will evaluate the Bids, including all clarifications, additional information, modifications and negotiated changes, by applying the Eligibility and Qualification Criteria. Without limiting the particular criteria, the Purchaser may take into account the following in the Evaluation of Bids:</p> <ul style="list-style-type: none"> <li>i. Non-performance by a Bidder on previous contracts with Purchaser or others;</li> <li>ii. The quality of a Bidder’s performance on previous contracts with Purchaser or others;</li> <li>iii. Anticipated or ongoing claims with or in connection with a Bidder;</li> <li>iv. Any security of safety concerns which Purchaser may have in respect of a Bidder or its facilities, subcontractors or suppliers;</li> <li>v. The results of any interview with a Bidder or supplied references; or</li> <li>vi. Any knowledge of or experience with a Bidder or its principals, directions, officers and employees.</li> </ul> <p>The Purchaser may independently verify any information (including conducting credit, reference and other checks with respect to a Bidder) and consider such findings in its evaluation.</p> <p>Purchaser is not required to inform Bidders of how Bids were ranked in the evaluation process.</p>
<b>IB 32.2</b>	<p>The comparison of bids shall be made with respect to prices quoted on FCS (Free Delivery to Consignee’s Store) basis, to be delivered at C-Type store, 500KV Grid Station, NGC, Multan as per quantities mentioned in Schedule A (Price Schedule).</p>
<b>IB 33.1</b>	<p>The Purchaser will determine to its satisfaction whether the Bidder is qualified to satisfactorily perform the contract. The Purchaser shall be the sole judge in this regard and the Purchaser’s interpretation of the Qualification Requirement shall be final and binding.</p>

<b>IB 33.2</b>	The Purchaser reserves the right to assess the capacity and capability of the Bidder, to successfully execute the scope of work covered under the Bidding Documents within stipulated completion period. This assessment shall include (i) document verification; (ii) Bidders work/manufacturing facilities visit; (iii) manufacturing capacity, details of work executed, work in hand, anticipated in future and the balance capacity available for the present scope of work; (iv) details of plant & machinery, manufacturing and testing facilities, and financial resources; (vi) past experience and performance; (vii) customer feedback (viii) Banker's feedback etc.
<b>IB 35.1</b>	Competent authority reserves the right to accept or reject any offer or a part thereof without assigning any reason. The offer received incomplete or not in accordance with the conditions/specifications will not be entertained. The Purchaser reserves the right to reject any Bid on the following accounts: <ul style="list-style-type: none"> <li>i. Bid is not received by the due date and time specified.</li> <li>ii. Cost of the Bidding documents is not remitted.</li> <li>iii. Bid is not accompanied by Bid security as specified in the document; Bid security is inadequate; Bid guarantee is not in the specified format.</li> <li>iv. Bid does not cover the complete scope of supply with all accessories.</li> <li>v. Bid does not contain all required particulars as per Schedules &amp; Forms prescribed in the Bidding documents. Bids not containing signed integrity pact will be rejected.</li> <li>vi. Deviations, conditionality or reservations have been introduced to any part of the Bidding documents which may not be acceptable to the Purchaser in its sole discretion.</li> <li>vii. Bidder does not respond promptly and thoroughly to the request for supplementary information required for the evaluation of his Bid.</li> <li>viii. Bid does not meet minimum acceptable standards of completeness, consistency and detail.</li> <li>ix. The offer is from a firm that is blacklisted by PEPCO, NGC, WAPDA, any other government organization and any donor agency operating in Pakistan or is in litigation with any government organization or is defaulter in any previous order and/or contract.</li> <li>x. If any time it is found that a material misrepresentation of facts is made or uncovered; the information submitted by the Bidder concerning his qualification was false and materially inaccurate or incomplete. If the Bidder is the Lead Member of a consortium, then the entire consortium may be disqualified/rejected.</li> </ul>
<b>IB 35.2</b>	Percentage increase or decrease shall not exceed 15%
<b>IB 37.1</b>	The Bidder shall furnish an unconditional performance security, equal to ten percent (10%) of the Contract Price (as detailed in Section-VI of the Bidding document).
<b>IB 42.1</b>	Margin of preference shall not apply.

**SECTION-III**  
**FORM OF BID**

**FORM OF TECHNICAL BID**

Date:

Bid for Contract No: \_\_\_\_\_  
\_\_\_\_\_  
\_\_\_\_\_

To:

Chief Engineer, Asset Management North NGC  
GSO House, Sher Shah Road, Cantt. Multan

Gentleman,

We, the undersigned, declare that:

- (a) We have examined and have no reservations to the Bidding Documents, including Addenda No.: \_\_\_\_\_;
- (b) We offer to supply in conformity with the Bidding Documents and in accordance with the Delivery and Completion Schedule, the Goods as stated below on FCS basis.

\_\_\_\_\_  
\_\_\_\_\_  
\_\_\_\_\_

[Bidder to delete item(s) not quoted in its Bid]

- (c) We undertake that the Bid Security and Schedules A and/or B as per requirements of the Bidding Documents are enclosed with the Price Bid.
- (d) Our Bid shall be valid for a period of \_\_\_\_\_ days from the date fixed for the bid submission deadline in accordance with the Bidding Document, and it shall remain binding upon us and may be accepted at any time before the expiration of that period;
- (e) If our Bid is accepted, we commit to submit a Performance Security for the due performance of the Contract;
- (f) We understand that our Bid (Technical Bid & Price Bid), together with your written acceptance thereof included in your Letter of Acceptance, shall constitute a binding contract between us, until a formal Contract is prepared and executed.
- (g) Our firm, including any subcontractors or suppliers for any part of the Contract, have nationalities from the following eligible countries \_\_\_\_\_;

- (h) We are not participating as Bidders, in more than one Bid in this bidding process, other than alternative offers in accordance with the Bidding Document;
- (i) Our firm, its affiliates or subsidiaries, including any subcontractors or suppliers for any part of the Contract, has not been declared ineligible/black listed by the Purchaser;
- (j) The following commissions, gratuities, or fees have been paid or are to be paid with respect to the bidding process or execution of the Contract:

Name of Recipient	Address	Reason	Amount
_____	_____	_____	_____
_____	_____	_____	_____

(If none has been paid or is to be paid, indicate "none.")

- (k) We agree to permit the Purchaser or its representative to inspect our accounts and records and other documents relating to the bid submission and to have them audited by auditors appointed by the Purchaser.
- (l) We understand that the Schedule B is attached hereto form part of this Technical Bid.

Name \_\_\_\_\_

In the capacity of \_\_\_\_\_

Signed and Stamped \_\_\_\_\_

Duly authorized to sign the Bid for and on behalf of \_\_\_\_\_ (Name of Bidder)

Date \_\_\_\_\_

Witness:

Name: \_\_\_\_\_

Signature: \_\_\_\_\_

Address: \_\_\_\_\_

**FORM OF PRICE BID**

Date:

Bid for Contract No: \_\_\_\_\_

\_\_\_\_\_  
\_\_\_\_\_  
\_\_\_\_\_

To:

Chief Engineer, Asset Management North NGC  
GSO House, Sher Shah Road, Cantt. Multan

Gentleman,

We, the undersigned, declare that:

- (a) We have examined and have no reservations to the Bidding Documents, including Addenda No.: \_\_\_\_\_;
- (b) We offer to supply in conformity with the Bidding Documents and in accordance with the Delivery and Completion Schedule, the Goods as stated below on .....FCS basis.

\_\_\_\_\_  
\_\_\_\_\_  
\_\_\_\_\_

[Bidder to delete item(s) not quoted in its Bid]

- (c) The total price of our Bid, excluding any discounts offered in item (d) below is:

Pak-Rupees \_\_\_\_\_

\_\_\_\_\_

and

Foreign Currency \_\_\_\_\_ (*amount in words*) \_\_\_\_\_ (*amount in figures*) \_\_\_\_\_

(d) The discounts, cross discounts offered and the methodology for their application are:

\_\_\_\_\_  
\_\_\_\_\_  
\_\_\_\_\_

(e) Our Bid shall be valid for a period of \_\_\_\_\_ days from the date fixed for the bid submission deadline in accordance with the Bidding Document, and it shall remain binding upon us and may be accepted at any time before the expiration of that period;

(f) If our Bid is accepted, we commit to submit a Performance Security for the due performance of the Contract;

(g) We understand that our Bid (Technical Bid & Price Bid), together with your written acceptance thereof included in your Letter of Acceptance, shall constitute a binding contract between us, until a formal Contract is prepared and executed.

(h) We understand that you are not bound to accept the lowest evaluated bid or any other bid that you may receive.

(i) We agree to permit the Purchaser or its representative to inspect our accounts and records and other documents relating to the bid submission and to have them audited by auditors appointed by the Purchaser.

(j) We understand that the Schedules A and/or B attached hereto form part of this Bid.

Name \_\_\_\_\_

In the capacity of \_\_\_\_\_

Signed and Stamped \_\_\_\_\_

Duly authorized to sign the Bid for and on behalf of \_\_\_\_\_ (Name of Bidder)

Date \_\_\_\_\_

Witness:

Name: \_\_\_\_\_

Signature: \_\_\_\_\_

Address: \_\_\_\_\_

**Appendix -A to Bidding Data**

**Undertaking of Bid Security**

*[To be submitted on Non-Judicial Stamp Paper]*

We, \_\_\_\_\_ *[Name of the Bidder]* undertake that the Bid Security meeting the requirements stipulated under Clause IB.19 has been enclosed with the Price Bid.

Signature and Seal of the Bidder:

**Appendix -B to Bidding Data****UNDERTAKING OF ACCEPTANCE OF AND COMPLIANCE WITH THE SOP FOR BLACKLISTING OF CONTRACTORS**

A) I, \_\_\_\_\_ [*Insert name and position of authorized signatory*] being duly authorized by \_\_\_\_\_ [*insert name of the Bidder*] to execute this undertaking of Acceptance of and Compliance with the “NGC’s SOP for Blacklisting of Contractors” attached herewith (hereinafter referred to as the “SOP”), hereby certify on behalf of the Bidder that we, \_\_\_\_\_ [*insert name of the Bidder*] have read and accept the provisions of the SOP.

B) I further certify, on behalf of the Bidder, that:

i) This Bid has been prepared and submitted in full compliance with the terms and conditions set forth in the SOP;

ii) We have not, directly or indirectly, taken any action which is or constitutes inter alia a corrupt, fraudulent, collusive or coercive act or practice in violation of the SOP; and

iii) We shall continue to comply with the terms and conditions of the SOP as and when amended, during period of evaluation of Bids and, in case we are selected for award of Contract, upto satisfactory completion of Contract.

\_\_\_\_\_  
**Authorized signatory**  
**For and on behalf of [*insert name of the Bidder*]**  
**Date:** \_\_\_\_\_

**SECTION-IV**  
**SCHEDULES TO BID**

## Schedule-A

**SCHEDULE OF PRICES**

Item No.	Description	Count ry of Origin	Unit	Qty	Unit Price FCS (PKR)	Total FCS Price (PKR)	Sales and Other Taxes (PKR)	Total Price FCS including Taxes (PKR)
1	2	3	4	5	6	7=5X6	8	9 = 7+8
<b>I</b>	<b>For Chief Engineer, Asset Management North NGC</b>							
1	Shirt Sky Blue		Nos.	360				
2	Trouser Navy Blue		Nos.	360				
3	Jersey Navy Blue V Neck Full Sleeve		Nos.	108				
4	Jacket with reflector stripes and NGC written on Back (Blue)		Nos.	111				
5	Rain Coat Blue (Water Proof)		Nos.	180				
6	Shoes Leather Black		Pairs	180				
7	Barret Cap Maroon			180				
8	Cap Badges Metal (NGC)		Nos.	179				
9	Arm Shield Round (NGC)		Nos.	188				
10	Laneyard Maroon & whistle		Nos.	180				
11	Vest Cotton Half sleeves		Nos.	321				
12	Belt Nylon Black (White Chrome Plate and NGC Badge) 86"		Nos.	113				
13	Shoulder Title Metal (NGC Security)		Nos.	272				
14	Socks Nylon Black (Pairs)		Pairs	284				
15	Rank Sergeant		Nos.	50				
16	Badges & Ranks of Inspector (Set of Stars) with Cloth Shoulder		Set	14				
17	Gloves Woolen Blue		Pairs	180				
18	Cap Comforter Woolen Blue		Nos.	180				
<b>Total</b>								

- Column 7: In Case of Discrepancy, between unit price and total, the unit price will prevail.
- Column 7 & 8: Currency in accordance with ITB Clause 13. Price shall include all custom duties and sales and other taxes already paid or payable on the components and raw material used in the manufacturer or assembly of the item or the custom duties and sales and other taxes already paid on previously imported items.
- Column 9: Payable in the Purchaser's country if Contract is awarded.  
Each item must be delivered at C-type store, 500KV grid station NGC Multan

Name \_\_\_\_\_

In the capacity of \_\_\_\_\_

Signed \_\_\_\_\_

Duly authorized to sign the Bid for and on behalf of \_\_\_\_\_

Date: \_\_\_\_\_

## Schedule-B

**DELIVERY AND COMPLETION SCHEDULE**

Item No.	Description	Unit	Qty	Delivery Period Required	Delivery Period Offered
				FCS C-type store, 500KV grid station NGC Multan following the date of signing of Contract Agreement	FCS C-type store, 500KV grid station NGC Multan following the date of signing of Contract Agreement
1	2	3	4	5	6
<b>I</b>	<b>For Chief Engineer, Asset Management North NGC</b>				
1	Shirt Sky Blue	Pairs		45-Days	
2	Trouser Navy Blue	Pairs		45-Days	
3	Jersey Navy Blue V Neck Full Sleeve	Nos.		45-Days	
4	Jacket with reflector stripes and NGC written on Back (Blue)	Nos.		45-Days	
5	Rain Coat Blue (Water Proof)	Nos.		45-Days	
6	Shoes Leather Black	Pairs		45-Days	
7	Barret Cap Maroon			45-Days	
8	Cap Badges Metal (NGC)	Nos.		45-Days	
9	Arm Shield Round (NGC)	Nos.		45-Days	
10	Laneyard Maroon & whistle	Nos.		45-Days	
11	Vest Cotton Half sleeves (White)	Nos.		45-Days	
12	Belt Nylon Black (White Crome Plate and NGC Badge) 86"	Nos.		45-Days	
13	Shoulder Title Metal (NGC Security)	Pairs		45-Days	
14	Socks Nylon Black (Pairs)	Pairs		45-Days	
15	Rank Sergeant	Nos.		45-Days	
16	Badges & Ranks of	Set		45-Days	

	Inspector ( Set of Stars) with Cloth Shoulder				
17	Gloves Woolen Blue	Pairs		45-Days	
18	Cap Comforter Woolen Blue	Nos.		45-Days	

**SEAL & SIGNATURE OF BIDDER**

**Schedule-C****DEVIATIONS FROM TECHNICAL PROVISIONS**

Note: Attach additional sheets, if necessary. Non listing of deviations, if any, shall make the tender non-responsive.

Sr. No.	Clause No. of Technical Specifications	Variation	Remarks (Including Justification)

Signature and seal of the  
Manufacturer/Bidder

Note:-

1. Bidders must recognize that substantial deviations may render the Bid substantially non responsive and subject to rejection.
2. Where there is no deviation, the statement should be returned duly signed with an endorsement indicating “No Deviations”.

**Schedule –D****DEVIATIONS FROM CONTRACTUAL CONDITIONS**

It is presumed that the bidder shall not take any deviation. However, if he intends to take deviations to the specified Contractual/Commercial Conditions, these must be listed in the space provided below:

Sr. No.	Clause No. / Section No.	Deviations/Clarifications

[Note: Attach additional sheets, if necessary]

Signature and seal of the  
Manufacturer/Bidder

**SECTION-V**  
**QUALIFICATION FORMS**

## **QUALIFICATION FORMS**

QF-1	General Information
QF-2	Manufacturing Experience
QF-3	Manufacturer's Authorization Certificate
QF-4	Performance Statement Form
QF-5	Performance Certificate
QF-6	Current Contract Commitments
QF-7	Financial Data
QF-8	Annual Turnover Data
QF-9	Financial Resources
QF-10	Bank Certificate
QF-11	Pending Litigation

Note:-

1. These forms shall be filled up and furnished by the Bidder
2. If necessary, additional sheets may be added to the forms. Each page of each form should be clearly marked in the right top corner as follows: Form QF1, page 1; Form QF1, page 2, etc.
3. Some forms will require attachments. Such attachments should be clearly marked as follows: Attachment 1 to Form QF1, Attachment 2 to Form QF1, etc.

### QF-1. GENERAL INFORMATION

Bidder is requested to complete the information in this form. Nationality information of Bidders should also be provided.

1.	Name of Bidder	
2.	Head office address	
3.	Local office address (if any)	
4.	Telephone	Contract
5.	Facsimile	e-mail
6.	Place of incorporation/registration	Year of incorporation/registration
7.	Main lines of Business	
	1.	Since:
	2.	Since:
	3.	Since:
	4.	Since:

**Note:**

Copies of following credentials shall be attached:

- (a) Copy of incorporation/registration certificate
- (b) Organization chart

Signature and Seal of the manufacturer/Bidder:

**QF-2. MANUFACTURING EXPERIENCE**

1. Name of the Plant and Equipment: \_\_\_\_\_
2. Location and Address of manufacturing facilities: \_\_\_\_\_
3. Production capacity (average annual): \_\_\_\_\_
4. First year of manufacturing: \_\_\_\_\_
5. Quantity produced [Numbers]:
  - (i) 2021 : \_\_\_\_\_
  - (ii) 2022 : \_\_\_\_\_
  - (iii) 2023 : \_\_\_\_\_
  - (iv) 2024: \_\_\_\_\_
  - (v) 2025: \_\_\_\_\_
6. Manufactured under own License? Yes                  No
7. Manufactured under license from: \_\_\_\_\_
8. Manufactured in collaboration with: \_\_\_\_\_
9. Has the Bidder R&D Section? Yes                  No
10. Is the manufacturer certified or accredited by an organization? Yes                  No
11. Name the organization and type of certification/accreditation: \_\_\_\_\_  
(Attach copy)

Signature and Seal of the manufacturer

### QF-3. MANUFACTURER’S AUTHORIZATION

Date: \_\_\_\_\_

Bid Reference No.: \_\_\_\_\_

Invitation for Bid No.: \_\_\_\_\_

To: \_\_\_\_\_

WHEREAS WE \_\_\_\_\_ who are official manufacturers of \_\_\_\_\_ (name & descriptions of goods offered) having factories at (address of factory) \_\_\_\_\_ do hereby authorize M/s \_\_\_\_\_ (Name and address of Agent) to submit a Bid in relation to the Invitation for Bids indicated above, the purpose of which is to provide the following Goods, manufactured by us \_\_\_\_\_ and to subsequently negotiate and sign the Contract.

No company or firm or individual other than M/s \_\_\_\_\_ are authorized to bid, and conclude the contract for the above goods manufactured by us against this specific IFB.

We hereby extend our full guarantee and warranty in accordance with Clause 28 of the General Conditions of Contract, with respect to the Goods offered by the above firm in reply to this Invitation for Bids

Name \_\_\_\_\_

In the capacity of: \_\_\_\_\_

Signed \_\_\_\_\_

Duly authorized to sign the Authorization for and on behalf of \_\_\_\_\_

Date \_\_\_\_\_

**Note:** This letter of authority should be on the letter head of the manufacturer and should be signed by a person competent and having the power of attorney to legally bind the manufacturer. It should be included by the Bidder in its bid.

Signature and Seal of the manufacturer

### QF-4. MANUFACTURER/SUPPLIER SUPPLY RECORD

(For a period of Last 5 Years)

Name of the Equipment/Goods: .....

Order Placed by (full address of Purchaser)	Order No. and date	Description quantity of ordered equipment	Value of order	Date of completion of deliver as per contract	Date of actual completion of delivery	Remarks indicating reasons for late delivery, if any	Has the equipment been installed satisfactory ? (Attach a certificate from the purchaser/ consignee)	Contact person along with Telephone No., Fax No. and email address

Signature and Seal of the manufacturer/Bidder:

### QF-5. PERFORMANCE CERTIFICATE

It is certify that M/s. \_\_\_\_\_ has supplied the following materials for the quantities indicated against each.

Sr.No	Order No. & Date	Designation & address of order placing authority/User	Description of Material	Quantity	Performance of Material

The above mentioned material installed in our system and its performance is found satisfactory.

Date of issuing \_\_\_\_\_

Signature of issuing authority with seal  
Name and Designation of issuing authority  
Address along with Phone No. and  
Fax of issuing authority

Note: In case of those bidders who have supplied the similar or higher rating material to NGC shall furnish the details of such supplies in the above performa which shall be signed by their authorized signatory along with seal and certificates is not required from the Purchaser/ User in respect of such supplies.

### QF-6. CURRENT CONTRACT COMMITMENTS

Bidders should provide information on their current commitments on all contracts that have been awarded, or for which a letter of intent or acceptance has been received, or for contracts approaching completion, but for which an unqualified, full completion certificate has yet to be issued.

<b>Sr. No.</b>	<b>Particulars of works executed</b>	<b>Order No. &amp; Date</b>	<b>Name of order placing Authority</b>	<b>Ordered Value (in)</b>	<b>Value of balance work (in)</b>
<b>1</b>	<b>2</b>	<b>3</b>	<b>4</b>	<b>5</b>	<b>6</b>
2					
3					
4					
5					
6					
7					

Signature and Seal of the manufacturer/Bidder:

### QF-7. FINANCIAL DATA

<b>Financial Data for Previous 3 Years</b>			
<b>Particular</b>	<b>2023</b>	<b>2024</b>	<b>2025</b>
<b>Information for Balance Sheet</b>			
<b>Total Assets</b>			
<b>Total Liabilities</b>			
<b>Net Worth</b>			
<b>Current Assets</b>			
<b>Current Liabilities</b>			
<b>Information from Income Statement</b>			
<b>Total Revenues</b>			
<b>Profits Before Taxes</b>			
<b>Profits After Taxes</b>			
<ul style="list-style-type: none"> <li>• Attached are copies of financial statements (balance sheets including all related notes, and income statements) for the last three years, as indicated above, complying with the following conditions.</li> <li>• All such documents reflect the financial situation of the Bidder and not sister or parent companies.</li> <li>• Historic financial statements must be audited by a certified accountant.</li> <li>• Historic Financial statements must be complete, including all notes to the financial statements.</li> <li>• Historic financial statements must correspond to accounting periods already completed and audited (no statements for partial periods shall be requested or accepted).</li> </ul>			

Signature and Seal of the manufacturer/Bidder:

**QF-8. ANNUAL TURNOVER DATA**

Name of Bidder
----------------

Bidder are requested to complete the information in this form separately. The information supplied should be the annual turnover of the Bidder, in terms of the amounts billed to clients for each year for work in progress or completed.

Annual turnover data for the following last three fiscal years		
Year	Turnover	US\$ Equivalent
2023		
2024		
2025		

Signature and Seal of manufacturer/Bidder:

## QF-9. FINANCIAL RESOURCES

Specify proposed sources of financing, such as liquid assets, unencumbered real assets, lines of credit, and other financial means, net of current commitments, available to meet the total construction cash flow demands of the subject contract.

<b>Financial Resources</b>			
Sr.No.	Source of Financing	Amount (Currency)	Equivalent Amount (US\$/PKR)*
1.	Liquid Assets		
2.	Credit Lines		
3.	Other Financial Means		
5.	<b>Total</b> (1+2+3)		
6.	Current Commitments		
7.	Net Available Financial Resources (4-5)		

\*Converted to PKR/US\$ at exchange rate (selling) prevailing twenty-eight (28) days prior to deadline for submission of Bids.

Signature and Seal of manufacturer/Bidder:

### QF-10. BANK CERTIFICATE

This is to certify that M/s..... is a reputed company with a good financial standing.

If the contract for the work, namely,..... is awarded to the above firm, we shall be able to provide overdraft/credit facilities to the extent of Rs..... to meet their working capital requirements for executing the above contract.

Signature of Senior Bank Manager: \_\_\_\_\_  
Name of the Senior Bank Manager: \_\_\_\_\_  
Address of the Bank: \_\_\_\_\_

Stamp of the Bank

Note: Certificate should be on the letter head of the bank.

### QF-11. PENDING LITIGATION

Each Bidder must fill in this form.

<b>Pending Litigation</b>					
Year	Name of Other Party(s)	Matter of Dispute	Litigation where (Court/ arbitration)	Amount involved	Value of pending claim as a %age of net worth

Signature and Seal of manufacturer/Bidder:

**SECTION-VI**  
**GENERAL CONDITIONS OF  
CONTRACT**

# **GENERAL CONDITIONS OF CONTRACT**

## **1. Definitions**

1.1 The following words and expressions shall have the meanings hereby assigned to them:

- (a) “Contract” means the Agreement entered into between the Purchaser and the Supplier, together with the Contract Documents referred to therein, including all attachments, appendices, schedules and all documents incorporated by reference therein.
- (b) “Contract Documents” means the documents listed in the Agreement, including any amendments thereto.
- (c) “Contract Price” means the price payable to the Supplier as specified in the Agreement, subject to such additions and adjustments thereto or deductions therefrom, as may be made pursuant to the Contract.
- (d) “Day” means calendar day.
- (e) “Delivery” means the transfer of the Goods from the Supplier to the Purchaser in accordance with the terms and conditions set forth in the Contract.
- (f) “Completion” means the fulfillment of the supply of Goods by the Supplier in accordance with the terms and conditions set forth in the Contract.
- (g) “Eligible Countries” means the countries as per Appendix-A.
- (h) “GCC” means the General Conditions of Contract.
- (i) “Goods” means all of the commodities, raw material, machinery and equipment, and/or other materials that the Supplier is required to supply to the Purchaser under the Contract.
- (j) “Purchaser’s Country” is the country specified in the Particular Conditions of Contract (PCC).
- (k) The “Purchaser” means the Employer who is the entity purchasing the Goods, as specified in the PCC, and includes the legal successors or assigns of the Purchaser.

- (l) “PCC” means the Particular Conditions of Contract.
- (m) “Subcontractor” means any natural person, private or government entity or a combination of the above, including its legal successors or permitted assigns, to whom any part of the Goods to be supplied is subcontracted by the Supplier.
- (n) “Supplier” means the natural person, private or government entity, or a combination of the above, whose bid to perform the Contract has been accepted by the Purchaser and is named as such in the Agreement, and includes the legal successors or permitted assigns of the Supplier.
- (o) “The Site,” where applicable, means the place named in the PCC.

**2. Contract Document**

- 2.1 Subject to the order of precedence set forth in the Agreement, all documents forming the Contract (and all parts thereof) are intended to be correlative, complementary, and mutually explanatory.

**3. Corrupt and Fraudulent Practices**

- 3.1
- (a) For the purposes of this provision, the term “Corrupt and Fraudulent Practices” includes the offering, giving, receiving, or soliciting of anything of value to influence the action of a public official or the supplier or contractor in the procurement process or in contract execution to the detriment of the procuring agencies; or misrepresentation of facts in order to influence a procurement process or the execution of a contract, collusive practices among bidders (prior to or after bid submission) designed to establish bid prices at artificial, non-competitive levels and to deprive the procuring agencies of the benefits of free and open competition and any request for, or solicitation of anything of value by any public official in the course of the exercise of his duty.
  - (b) The Purchaser will reject a proposal for award if it determines that the bidder recommended for award has, directly or through an agent, engaged in corrupt and fraudulent practices in competing for the Contract.
- 3.2 The Supplier shall permit the Purchaser to inspect the Supplier’s accounts and records relating to the performance of the Supplier and to have them audited by auditors appointed by the Purchaser, if so required by the Purchaser.

**4. Interpretation** 4.1 If the context so requires it, singular means plural and vice versa where the context requires.

4.2 Incoterms

The meaning of any trade term and the rights and obligations of parties there under shall be as prescribed by Incoterms.

- (a) EXW, CIF, DDP, and other similar terms, shall be governed by the rules prescribed in the current edition of Incoterms, published by the International Chamber of Commerce at the date of the Invitation for Bids or as specified in the PCC.

4.3 Entire Agreement

The Contract constitutes the entire agreement between the Purchaser and the Supplier and supersedes all communications, negotiations and agreements (whether written or oral) of parties with respect thereto made prior to the date of Contract.

4.4 Amendment

No amendment or other variation of the Contract shall be valid unless it is in writing, is dated, expressly refers to the Contract, and is signed by a duly authorized representative of each party thereto.

4.5 Non waiver

- (a) Subject to GCC Sub-Clause 4.5(b) below, no relaxation, forbearance, delay, or indulgence by either party in enforcing any of the terms and conditions of the Contract or the granting of time by either party to the other shall prejudice, affect, or restrict the rights of that party under the Contract, neither shall any waiver by either party of any breach of Contract operate as waiver of any subsequent or continuing breach of Contract.
- (b) Any waiver of a party's rights, powers, or remedies under the Contract must be in writing, dated, and signed by an authorized representative of the party granting such waiver, and must specify the right and the extent to which it is being waived.

#### 4.6 Severability

If any provision or condition of the Contract is prohibited or rendered invalid or unenforceable, such prohibition, invalidity or unenforceability shall not affect the validity or enforceability of any other provisions and conditions of the Contract.

### 5. Language

5.1 The Contract as well as all correspondence and documents relating to the Contract exchanged by the Supplier and the Purchaser, shall be written in the language specified in the PCC. Supporting documents and printed literature that are part of the Contract may be in another language provided they are accompanied by an accurate translation of the relevant passages in the language specified in the PCC, in which case, for purposes of interpretation of the Contract, this translation shall govern.

5.2 The Supplier shall bear all costs of translation to the governing language and all risks of the accuracy of such translation.

### 6. Joint Venture, Consortium or Association

6.1 Unless otherwise specified in the PCC, if the Supplier is a joint venture, consortium, or association, all of the parties shall be jointly and severally liable to the Purchaser for the fulfillment of the provisions of the Contract and shall designate one party to act as a leader with authority to bind the joint venture, consortium, or association. The composition or the constitution of the joint venture, consortium, or association shall not be altered without the prior consent of the Purchaser.

### 7. Eligibility

7.1 The Supplier and its Subcontractors shall have the nationality of an Eligible Country in case of International Competitive Bidding but only of Pakistan in case National Competitive Bidding. A Supplier or Subcontractor shall be deemed to have the nationality of a country if it is a citizen or constituted or incorporated, and operates in conformity with the provisions of the laws of that country.

7.2 All Goods to be supplied under the Contract and financed by the Purchaser shall have their origin in Eligible Countries. For the purpose of this Clause, origin means the country where the goods have been grown, mined, cultivated, produced, manufactured, or processed; or through manufacture, processing, or assembly, another commercially recognized article results that differs substantially in its basic characteristics from its imported components.

- 8. Notices**
- 8.1 Any Notice given by one party to the other pursuant to the Contract shall be in writing to the address specified in the PCC. The term “in writing” means communicated in written form with proof of receipt.
- 8.2 A Notice shall be effective when delivered or on the Notice’s effective date, whichever is later.
- 9. Governing Law**
- 9.1 The Contract shall be governed by and interpreted in accordance with the laws of the Purchaser’s country, unless otherwise specified in the PCC.
- 10. Settlement of Disputes**
- 10.1 The Purchaser and the Supplier shall make every effort to resolve amicably by direct informal negotiation any disagreement or dispute arising between them under or in connection with the Contract.
- 10.2 If the parties fail to resolve such a dispute or difference by mutual consultation within twenty-eight (28) days from the commencement of such consultation, either party may require that the dispute be referred for resolution to the formal mechanisms specified in the PCC.
- 11. Scope of Supply**
- 11.1 Subject to the PCC, the Goods to be supplied shall be as specified in Schedules to Bid.
- 11.2 Unless otherwise stipulated in the Contract, the Scope of Supply shall include all such items not specifically mentioned in the Contract but that can be reasonably inferred from the Contract as being required for attaining Delivery and Completion of the Goods as if such items were expressly mentioned in the Contract.
- 12. Delivery**
- 12.1 Subject to GCC Sub-Clause 33.1, the Delivery of the Goods shall be in accordance with the Delivery and Completion Schedule specified in the Schedules to Bid. The details of shipping and other documents to be furnished by the Supplier are specified in the PCC.
- 13. Supplier’s Responsibilities**
- 13.1 The Supplier shall supply all the Goods included in the Scope of Supply in accordance with GCC Clause 11, and the Delivery and Completion Schedule, as per GCC Clause 12.
- 14. Purchaser’s Responsibilities**
- 14.1 Whenever the supply of Goods requires that the Supplier obtain permits, approvals, and import and other licenses from local public authorities, the Purchaser shall, if so required by the Supplier, make its best effort to assist the Supplier in

complying with such requirements in a timely and expeditious manner.

14.2 The Purchaser shall afford all costs involved in the performance of its responsibilities, in accordance with GCC Sub-Clause 14.1.

**15. Contract Price**

15.1 The Contract Price shall be as specified in the Agreement subject to any additions and adjustments thereto, or deductions therefrom, as may be made pursuant to the Contract.

15.2 Prices charged by the Supplier for the Goods delivered under the Contract shall not vary from the prices quoted by the Supplier in its bid, with the exception of any price adjustments authorized as per the formula if given in GCC Sub-Clause 15.3.

15.3 The Purchaser should develop the formula and other factors for Price Adjustment based on the principle of Clause 70.1 of PEC Bidding Documents for Civil Works and Standard Procedure and Formulae for Price Adjustment prepared by PEC, with following modifications:

- i. Adjustable material would be those raw materials used for manufacturing of specific Goods Items on which, in opinion of the Purchaser, the price adjustment is payable. However, the Purchaser shall calculate, to make project specific price adjustment formula, the appropriate weightages of major raw materials as per the PEC standard documents mentioned above.
- ii. In case of adjustable materials and labor, the current price indices shall be 42 days prior to date of Goods transport [or any other appropriate period may be incorporated by the Purchaser representing the mid-point of the period of manufacture], while in case of POL, the current price indices shall be 15 days [or any other reasonable period may be incorporated by the Purchaser] before the date of Goods transport.
- iii. Source for indices:
  - a. For Local Manufactured Items;  
PICC cost data or any other credible source to be mentioned in bidding documents, failing which to be agreed between parties before signing the Contract.

- b. For Foreign Manufactured Items;  
London Metal Exchange (LME) Rate

OR

The Purchaser shall state “This is a Fixed Price Contract” in case the Price Adjustment is not applicable for lesser time of delivery or smaller quantities of Goods to be supplied.

**16. Terms of Payment**

- 16.1 The Contract Price shall be paid as specified in the PCC.
- 16.2 The Supplier’s request for payment shall be made to the Purchaser in writing, accompanied by invoices describing, as appropriate, the Goods delivered by the documents submitted pursuant to GCC Clause 12 and upon fulfillment of all the obligations stipulated in the Contract.
- 16.3 Payments shall be made promptly by the Purchaser, no later than sixty (60) days after submission of an invoice or request for payment by the Supplier, and the Purchaser has accepted it.
- 16.4 The currency or currencies in which payments shall be made to the Supplier under this Contract shall be specified in the PCC.

**17. Taxes and Duties**

- 17.1 For Goods supplied from outside the Purchaser’s Country, the Supplier shall be entirely responsible for all taxes, stamp duties, license fees, and other such levies imposed outside the Purchaser’s Country.
- 17.2 For Goods supplied from within the Purchaser’s Country, the Supplier shall be entirely responsible for all taxes, duties, license fees, etc., incurred until delivery of the contracted Goods to the Purchaser.
- 17.3 If any tax exemptions, reductions, allowances or privileges may be available to the Supplier in the Purchaser’s Country, the Purchaser shall use its best efforts to enable the Supplier to benefit from any such tax savings to the maximum allowable extent.

**18. Performance Security**

- 18.1 The Supplier shall, within twenty-eight (28) days of the notification of Contract award, provide a Performance Security for the due performance of the Contract in the amounts and currencies specified in the PCC.

18.2 The proceeds of the Performance Security shall be payable to the Purchaser as compensation for any loss resulting from the Supplier's failure to complete its obligations under the Contract.

18.3 The Performance Security shall be denominated in the currencies of the Contract, or in a freely convertible currency acceptable to the Purchaser, and shall be in one of the forms stipulated by the Purchaser in the PCC, or in another form acceptable to the Purchaser.

18.4 The Performance Security shall be discharged by the Purchaser and returned to the Supplier not later than twenty-eight (28) days following the date of completion of the Supplier's performance obligations under the Contract, including any warranty obligations, unless specified otherwise in the PCC.

## **19. Copyright**

19.1 The copyright in all drawings, documents, and other materials containing data and information furnished to the Purchaser by the Supplier herein shall remain vested in the Supplier, or, if they are furnished to the Purchaser directly or through the Supplier by any third party, including suppliers of materials, the copyright in such materials shall remain vested in such third party.

## **20. Confidential Information**

20.1 The Purchaser and the Supplier shall keep confidential and shall not, without the written consent of the other party hereto, divulge to any third party any documents, data, or other information furnished directly or indirectly by the other party hereto in connection with the Contract, whether such information has been furnished prior to, during or following completion or termination of the Contract. Notwithstanding the above, the Supplier may furnish to its Subcontractor such documents, data, and other information it receives from the Purchaser to the extent required for the Subcontractor to perform its work under the Contract, in which event the Supplier shall obtain from such Subcontractor an undertaking of confidentiality similar to that imposed on the Supplier under GCC Clause 20.

20.2 The Purchaser shall not use such documents, data, and other information received from the Supplier for any purposes unrelated to the Contract. Similarly, the Supplier shall not use such documents, data, and other information received from the Purchaser for any purpose other than the design, procurement, required for the performance of the Contract.

- 20.3 The obligation of a party under GCC Sub-Clauses 20.1 and 20.2 above, however, shall not apply to information that:
- (a) The Purchaser or Supplier need to share with the purchaser or other institutions participating in the financing of the Contract;
  - (b) Now or hereafter enters the public domain through no fault of that party;
  - (c) Can be proven to have been possessed by that party at the time of disclosure and which was not previously obtained, directly or indirectly, from the other party; or
  - (d) Otherwise lawfully becomes available to that party from a third party that has no obligation of confidentiality.
- 20.4 The above provisions of GCC Clause 20 shall not in any way modify any undertaking of confidentiality given by either of the parties hereto prior to the date of the Contract in respect of the Supply or any part thereof.
- 20.5 The provisions of GCC Clause 20 shall survive completion or termination, for whatever reason, of the Contract.

**21. Subcontracting**

- 21.1 The Supplier shall notify the Purchaser in writing of all subcontracts awarded under the Contract if not already specified in the Bid. Subcontracting shall in no event relieve the Supplier from any of its obligations, duties, responsibilities, or liability under the Contract.
- 21.2 Subcontracts shall comply with the provisions of GCC Clauses 3 and 7.

**22. Specifications and Standards**

- 22.1 Technical Specifications and Drawings
- (a) The Supplier shall ensure that the Goods comply with the technical specifications and other provisions of the Contract.
  - (b) The Supplier shall be entitled to disclaim responsibility for any design, data, drawing, specification or other document, or any modification thereof provided or designed by or on behalf of the Purchaser, by giving a notice of such disclaimer to the Purchaser.

- (c) The Goods supplied under this Contract shall conform to the standards mentioned in the Schedules to Bid and, when no applicable standard is mentioned, the standard shall be equivalent or superior to the official standards whose application is appropriate to the country of origin of the Goods.

22.2 Wherever references are made in the Contract to codes and standards in accordance with which it shall be executed, the edition or the revised version of such codes and standards shall be those specified in the Schedules to Bid. During Contract execution, any changes in any such codes and standards shall be applied only after approval by the Purchaser and shall be treated in accordance with GCC Clause 33.

**23. Packing and Documents**

23.1 The Supplier shall provide such packing of the Goods as is required to prevent their damage or deterioration during transit to their final destination, as indicated in the Contract. During transit, the packing shall be sufficient to withstand, without limitation, rough handling and exposure to extreme temperatures, salt and precipitation, and open storage. Packing case size and weights shall take into consideration, where appropriate, the remoteness of the final destination of the Goods and the absence of heavy handling facilities at all points in transit.

23.2 The packing, marking, and documentation within and outside the packages shall comply strictly with such special requirements as shall be expressly provided for in the Contract, including additional requirements, if any, specified in the PCC, and in any other instructions ordered by the Purchaser.

**24. Insurance**

24.1 Unless otherwise specified in the PCC, the Goods supplied under the Contract shall be fully insured, in a freely convertible currency from an eligible country, against loss or damage incidental to manufacture or acquisition, transportation, storage, and delivery, in accordance with the applicable Incoterms or in the manner specified in the PCC.

**25. Transportation**

25.1 Unless otherwise specified in the PCC, obligations for transportation of the Goods shall be in accordance with the Incoterms specified in the Schedules A and B to Bid.

**26. Inspections and Tests**

26.1 The Supplier shall at its own expense and at no cost to the Purchaser carry out all such tests and /or inspections of the

Goods as are specified in the Schedules to Bid.

- 26.2 The inspections and tests may be conducted on the premises of the Supplier or its Subcontractor, at point of delivery, and/or at the final destination of the Goods, or in another place in the Purchaser's country as specified in the PCC. Subject to GCC Sub-Clause 26.3, if conducted on the premises of the Supplier or its Subcontractor, all reasonable facilities and assistance, including access to drawings and production data, shall be furnished to the inspectors at no charge to the Purchaser.
- 26.3 The Purchaser or its designated representative shall be entitled to attend the tests and/or inspections referred to in GCC Sub-Clause 26.2, provided that the Purchaser bear all of its own costs and expenses incurred in connection with such attendance including, but not limited to, all traveling and board and lodging expenses.
- 26.4 Whenever the Supplier is ready to carry out any such test and inspection, it shall give a reasonable advance notice, including the place and time, to the Purchaser. The Supplier shall obtain from any relevant third party or manufacturer any necessary permission or consent to enable the Purchaser or its designated representative to attend the test and/or inspection.
- 26.5 The Purchaser may require the Supplier to carry out any test and/or inspection not required by the Contract but deemed necessary to verify that the characteristics and performance of the Goods comply with the technical specifications, codes and standards under the Contract, provided that the Supplier's reasonable costs and expenses incurred in the carrying out of such test and/or inspection shall be added to the Contract Price. Further, if such test and/or inspection impedes the progress of manufacturing and/or the Supplier's performance of its other obligations under the Contract, due allowance will be made in respect of the Delivery Dates and Completion Dates and the other obligations so affected.
- 26.6 The Supplier shall provide the Purchaser with a report of the results of any such test and/or inspection.
- 26.7 The Purchaser may reject any Goods or any part thereof that fail to pass any test and/or inspection or do not conform to the specifications. The Supplier shall either rectify or replace such rejected Goods or parts thereof or make alterations necessary to meet the specifications at no cost to the Purchaser, and shall repeat the test and/or inspection, at no cost to the Purchaser, upon giving a notice pursuant to GCC

Sub-Clause 26.4.

26.8 The Supplier agrees that neither the execution of a test and/or inspection of the Goods or any part thereof, nor the attendance by the Purchaser or its representative, nor the issue of any report pursuant to GCC Sub-Clause 26.6, shall release the Supplier from any warranties or other obligations under the Contract.

**27. Liquidated Damages**

27.1 Except as provided under GCC Clause 32, if the Supplier fails to deliver any or all of the Goods within the period specified in the Contract, the Purchaser may without prejudice to all its other remedies under the Contract, deduct from the Contract Price, as liquidated damages, a sum equivalent to the percentage specified in the PCC of the Contract Price for each week or part thereof of delay until actual delivery or performance, up to a maximum deduction of the percentage specified in the PCC. Once the maximum is reached, the Purchaser may terminate the Contract pursuant to GCC Clause 35.

**28. Warranty**

28.1 The Supplier warrants that all the Goods are new, unused, and of the most recent or current models, and that they incorporate all recent improvements in design and materials, unless provided otherwise in the Contract.

28.2 Subject to GCC Sub-Clause 22.1, the Supplier further warrants that the Goods shall be free from defects arising from any act or omission of the Supplier or arising from design, materials, and workmanship, under normal use in the conditions prevailing in the country of final destination.

28.3 Unless otherwise specified in the PCC, the warranty shall remain valid for twenty four (24) months after the Goods, or any portion thereof as the case may be, have been delivered to and accepted at the final destination indicated in the PCC, or for eighteen (18) months after the date of shipment or loading in the country of origin, whichever period concludes earlier.

28.4 The Purchaser shall give Notice to the Supplier stating the nature of any such defects together with all available evidence thereof, promptly following the discovery thereof. The Purchaser shall afford all reasonable opportunity for the Supplier to inspect such defects.

28.5 Upon receipt of such Notice, the Supplier shall, within the period specified in the PCC, expeditiously repair or replace the defective Goods or parts thereof, at no cost to the Purchaser.

28.6 If having been notified, the Supplier fails to remedy the defect within the period specified in the PCC, the Purchaser may proceed to take within a reasonable period such remedial action as may be necessary, at the Supplier's risk and expense and without prejudice to any other rights which the Purchaser may have against the Supplier under the Contract.

**29. Patent  
Indemnity**

29.1 The Supplier shall, subject to the Purchaser's compliance with GCC Sub-Clause 29.2, indemnify and hold harmless the Purchaser and its employees and officers from and against any and all suits, actions or administrative proceedings, claims, demands, losses, damages, costs, and expenses of any nature, including attorney's fees and expenses, which the Purchaser may suffer as a result of any infringement or alleged infringement of any patent, utility model, registered design, trademark, copyright, or other intellectual property right registered or otherwise existing at the date of the Contract by reason of:

- (a) The installation of the Goods by the Supplier or the use of the Goods in the country where the Site is located; and
- (b) The sale in any country of the products produced by the Goods.

Such indemnity shall not cover any use of the Goods or any part thereof other than for the purpose indicated by or to be reasonably inferred from the Contract, neither any infringement resulting from the use of the Goods or any part thereof, or any products produced thereby in association or combination with any other equipment, plant, or materials not supplied by the Supplier, pursuant to the Contract.

29.2 If any proceedings are brought or any claim is made against the Purchaser arising out of the matters referred to in GCC Sub-Clause 29.1, the Purchaser shall promptly give the Supplier a notice thereof, and the Supplier may at its own expense and in the Purchaser's name conduct such proceedings or claim and any negotiations for the settlement of any such proceedings or claim.

- 29.3 If the Supplier fails to notify the Purchaser within twenty-eight (28) days after receipt of such notice that it intends to conduct any such proceedings or claim, then the Purchaser shall be free to conduct the same on its own behalf.
- 29.4 The Purchaser shall, at the Supplier's request, afford all available assistance to the Supplier in conducting such proceedings or claim, and shall be reimbursed by the Supplier for all reasonable expenses incurred in so doing.
- 29.5 The Purchaser shall indemnify and hold harmless the Supplier and its employees, officers, and Subcontractors from and against any and all suits, actions or administrative proceedings, claims, demands, losses, damages, costs, and expenses of any nature, including attorney's fees and expenses, which the Supplier may suffer as a result of any infringement or alleged infringement of any patent, utility model, registered design, trademark, copyright, or other intellectual property right registered or otherwise existing at the date of the Contract arising out of or in connection with any design, data, drawing, specification, or other documents or materials provided or designed by or on behalf of the Purchaser.

**30. Limitation of Liability**

- 30.1 Except in cases of gross negligence or willful misconduct :
- (a) Neither party shall be liable to the other party for any indirect or consequential loss or damage, loss of use, loss of production, or loss of profits or interest costs, provided that this exclusion shall not apply to any obligation of the Supplier to pay liquidated damages to the Purchaser; and
- (b) The aggregate liability of the Supplier to the Purchaser, whether under the Contract, in tort, or otherwise, shall not exceed the amount specified in the PCC, provided that this limitation shall not apply to the cost of repairing or replacing defective equipment, or to any obligation of the Supplier to indemnify the Purchaser with respect to patent infringement.

**31. Change in Laws and Regulations**

- 31.1 Unless otherwise specified in the Contract, if after the date of the Invitation for Bids, any law, regulation, ordinance, order or bylaw having the force of law is enacted, promulgated, abrogated, or changed in the place of the Purchaser's country where the Site is located (which shall be deemed to include any change in interpretation or application by the competent

authorities) that subsequently affects the Delivery Date and/or the Contract Price, then such Delivery Date and/or Contract Price shall be correspondingly increased or decreased, to the extent that the Supplier has thereby been affected in the performance of any of its obligations under the Contract. Notwithstanding the foregoing, such additional or reduced cost shall not be separately paid or credited if the same has already been accounted for in the price adjustment provisions where applicable, in accordance with GCC Clause 15.

- 32. Force Majeure**
- 32.1 The Supplier shall not be liable for forfeiture of its Performance Security, liquidated damages, or termination for default if and to the extent that its delay in performance or other failure to perform its obligations under the Contract is the result of an event of Force Majeure.
- 32.2 For purposes of this Clause, “Force Majeure” means an event or situation beyond the control of the Supplier that is not foreseeable, is unavoidable, and its origin is not due to negligence or lack of care on the part of the Supplier. Such events may include, but not be limited to, acts of the Purchaser in its sovereign capacity, wars or revolutions, fires, floods, epidemics, quarantine restrictions, and freight embargoes.
- 32.3 If a Force Majeure situation arises, the Supplier shall promptly notify the Purchaser in writing of such condition and the cause thereof. Unless otherwise directed by the Purchaser in writing, the Supplier shall continue to perform its obligations under the Contract as far as is reasonably practical, and shall seek all reasonable alternative means for performance not prevented by the Force Majeure event.
- 33. Change Orders and Contract Amendments**
- 33.1 The Purchaser may at any time order the Supplier through Notice in accordance GCC Clause 8, to make changes within the general scope of the Contract in any one or more of the following:
- (a) Drawings, designs, or specifications, where Goods to be furnished under the Contract are to be specifically manufactured for the Purchaser;
  - (b) The method of shipment or packing;
  - (c) The place of delivery; and
  - (d) Any other

33.2 If any such change causes an increase or decrease in the cost of, or the time required for, the Supplier's performance of any provisions under the Contract, an equitable adjustment shall be made in the Contract Price or in the Delivery and Completion Schedule, or both, and the Contract shall accordingly be amended. Any claims by the Supplier for adjustment under this Clause must be asserted within twenty-eight (28) days from the date of the Supplier's receipt of the Purchaser's change order.

**34. Extensions of Time**

34.1 If at any time during performance of the Contract, the Supplier or its Subcontractors should encounter conditions impeding timely delivery of the Goods pursuant to GCC Clause 12, the Supplier shall promptly notify the Purchaser in writing of the delay, its likely duration, and its cause. As soon as practicable after receipt of the Supplier's notice, the Purchaser shall evaluate the situation and may at its discretion extend the Supplier's time for performance, in which case the extension shall be ratified by the parties by amendment of the Contract.

34.2 Except in case of Force Majeure, as provided under GCC Clause 32, a delay by the Supplier in the performance of its Delivery and Completion obligations shall render the Supplier liable to the imposition of liquidated damages pursuant to GCC Clause 27, unless an extension of time is agreed upon, pursuant to GCC Sub-Clause 34.1.

**35. Termination**

35.1 Termination for Default

(a) The Purchaser, without prejudice to any other remedy for breach of Contract, by Notice of default sent to the Supplier, may terminate the Contract in whole or in part:

(i) If the Supplier fails to deliver any or all of the Goods within the period specified in the Contract, or within any extension thereof granted by the Purchaser pursuant to GCC Clause 34; or

(ii) If the Supplier fails to perform any other obligation under the Contract.

(b) In the event the Purchaser terminates the Contract in whole or in part, pursuant to GCC Clause 35.1(a), the Purchaser may procure, upon such terms and in such manner as it deems appropriate, Goods or Related Services similar to those undelivered or not performed,

and the Supplier shall be liable to the Purchaser for any additional costs for such similar Goods. However, the Supplier shall continue performance of the Contract to the extent not terminated.

- (c) If the Supplier, in the judgment of the Purchaser has engaged in corrupt and fraudulent practices, as defined in GCC Clause 3, in competing for or in executing the Contract.

### 35.2 Termination for Insolvency

The Purchaser may at any time terminate the Contract by giving Notice to the Supplier if the Supplier becomes bankrupt or otherwise insolvent. In such event, termination will be without compensation to the Supplier, provided that such termination will not prejudice or affect any right of action or remedy that has accrued or will accrue thereafter to the Purchaser.

### 35.3 Termination for Convenience

- (a) The Purchaser, by Notice sent to the Supplier, may terminate the Contract, in whole or in part, at any time for its convenience. The Notice of termination shall specify that termination is for the Purchaser's convenience, the extent to which performance of the Supplier under the Contract is terminated, and the date upon which such termination becomes effective.

- (b) The Goods that are complete and ready for shipment within twenty-eight (28) days after the Supplier's receipt of the Notice of termination shall be accepted by the Purchaser at the Contract terms and prices. For the remaining Goods, the Purchaser may elect:

- (i) To have any portion completed and delivered at the Contract terms and prices; and/or
- (ii) To cancel the remainder and pay to the Supplier an agreed amount for partially completed Goods and for materials and parts previously procured by the Supplier.

## 36. Assignment

- 36.1 The Supplier shall not assign, in whole or in part, its obligations under this Contract, except with prior written consent of the Purchaser.



**SECTION-VII**

**PARTICULAR CONDITIONS OF  
CONTRACT**

## **PARTICULAR CONDITIONS OF CONTRACT**

The following Particular Conditions of Contract (PCC) shall supplement the General Conditions of Contract (GCC). Whenever there is a conflict, the provisions herein shall prevail over those in the GCC.	
<b>GCC Sub Clause 1.1 (g')</b>	Add the following new item after item (g):  (g') "Engineer" means Chief Engineer, Asset Management North NGC-Multan or the other person for the time being or from time to time duly appointed in writing by the Purchaser to act as the Engineer for the purposes of the Contract and includes such other persons (if any) to whom Engineer's authority may have been lawfully delegated pursuant to the Contract.
<b>GCC Sub Clause 1.1 (j)</b>	The Purchaser's country is: Islamic Republic of Pakistan
<b>GCC Sub Clause 1.1 (k)</b>	The Purchaser is: National Grid Company (NGC)
<b>GCC Sub Clause 1.1 (o)</b>	The Site for the Project is: C-type store, 500KV Grid Station NGC, Multan.
<b>GCC Sub Clause 3.1</b>	Add the following item after GCC Sub-Clause 3.1 (b):  (c) The purchaser will declare a bidder ineligible, either indefinitely or for stated period of time if purchase any time determines that the bidder has engaged in corrupt fraudulent practice in competing for or in executing the contract.
<b>GCC Sub Clause 4.1</b>	Add the following at the end of GCC Sub-Clause 4.1:  Heading have no significance. Words have their normal meaning under the language of the Contracts unless specifically defined. The Engineer will provide instructions clarifying queries about these Conditions of Contract.
<b>GCC Sub Clause 5.1</b>	The language shall be English.
<b>GCC Sub Clause 8.1</b>	For <b>notices</b> , the Purchaser's address shall be: Attention: Chief Engineer Asset Management North NGC Multan Address: Chief Engineer, Asset Management North NGC GSO House, Sher Shah Road, Cantt. Multan Telephone No. 92-61-9200515 Fax No. 92-61-9200516  The Supplier's address shall be: <i>[To be filled in at the time of signing of Contract.]</i>

<b>GCC Sub Clause 9.1</b>	The Contract shall be interpreted and construed in accordance with the laws of Islamic Republic of Pakistan
<b>GCC Sub Clause 10.2</b>	<p>Delete GCC Sub-Clause 10.2 and replace it with the following:</p> <p><b><u>(i) Engineer’s Decision</u></b></p> <p>If a dispute of any kind whatsoever arises between the Purchaser and the Supplier in connection with the Contract, the matter in dispute shall, in the first place, be referred in writing to the Engineer, with a copy to the other party. Such reference shall state that it is made pursuant this Clause. No later than the twenty-eight (28) days after the day on which he received such reference, the Engineer shall give notice of his decision to the Purchaser and the Supplier.</p> <p>Unless the Contract has already been repudiated or terminated, the Supplier shall, in every case, continue to proceed with the contract with all due diligence and the Supplier and the Purchaser shall give effect forthwith to every such decision of the Engineer unless and until the same shall be revised, as hereinafter provided in an arbitral award.</p> <p><b><u>(ii) Notice of Dissatisfaction</u></b></p> <p>If a Party is dissatisfied with the decision of the Engineer or if no decision is given within the time set out in Sub Clause 10.2(i) here above, the Party may give notice of dissatisfaction referring to this Sub Clause within 14 days of receipt of the decision or the expiry of the time for the decision. If no notice of dissatisfaction is given within the specified time, the decision shall be final and binding on the Parties. If notice of dissatisfaction is given within the specified time, the decision shall be binding on the Parties who shall give effect to it without delay unless and until the decision of the Engineer is revised by an Arbitrator.</p> <p><b><u>(iii) Arbitration</u></b></p> <p>A dispute which has been the subject of a notice of dissatisfaction shall be finally settled as per provisions of Arbitration Act 1940. Place of Arbitration shall be Multan, Pakistan.</p>
<b>GCC Sub Clause 11.1</b>	The scope of Goods Supply is described in Section IV (Schedules to Bid). At the time of awarding the contract, the purchaser may specify any change with respect to Delivery Schedule in Section IV (Schedules to Bid).

<b>GCC Sub Clause 12.1</b>	<p>A) Details of shipping and other documents to be furnished by the Supplier shall be:</p> <p>a) Four copies of the Supplier's invoice showing the description of the Goods, quantity, unit price, and total amount.</p> <p>b) Delivery note, railway receipt, or truck receipt.</p> <p>c) Manufacturer's or Supplier's warranty certificate.</p> <p>d) Inspection certificate issued by the nominated inspection agency, and the supplier's factory inspection report; and</p> <p>e) Certificate of origin.</p> <p>The Purchaser shall receive the above documents before the arrival of the Goods and, if not received, the Supplier will be responsible for any consequent expenses.</p>
<b>GCC Sub Clause 12.2</b>	<p>Add the following new Sub-Clause after GCC 12.1:</p> <p>12.2 Delivery shall be deemed to have been made:</p> <p>(a) in the case of ex-works/ex-factory, ex-show room, ex-warehouse or off-the –shelf contract, when evidence that delivery of the Goods has been taken place in accordance with the term of the Contract, together with the invoice(s) and all such other documentation as shall be specified by the Engineer/NGC have been submitted.</p> <p>(b) in the case of Contract including delivery of the Goods to NGC designated storage yard, when evidence that delivery of the Goods to the NGC designated storage yard has taken place in accordance with the terms of the Contract, together with documentation as shall be specified by the Engineer/NGC have submitted.</p>
<b>GCC Sub Clause 13.2</b>	<p>Add the following new Sub Clause after GCC 13.1:</p> <p>An un-excused delay by the Supplier in the performance of its delivery obligations shall render the Supplier liable to any or all of the following sanctions; forfeiture of its Performance Security, imposition of Liquidated Damages, and/or termination of the Contract for default.</p>
<b>GCC Sub Clause 15.3</b>	<p>This is a fixed price Contract.</p>
<b>GCC Sub Clause 16.1</b>	<p>The terms of payment shall be:</p> <p>The payment shall be made through direct disbursement procedure by Finance Director NGC, WAPDA House Lahore through any scheduled bank of Pakistan in favor of supplier.</p> <p>For Goods and Related Services supplied from within the Purchaser's Country:</p> <p><b>a) On Delivery:</b> 90% payment of the Contract price against goods delivered upon presentation of documents</p>

	<p>as per GCC Sub clause 12.1, Section-VII (Particular Conditions of Contract).</p> <p><b>b) On Acceptance:</b> Ten (10) percent of the Contract Price of Goods received shall be paid by NGC from its own resources on receipt of the Goods upon submission of a claim supported by the acceptance certificate issued by the Purchaser</p>
<b>GCC Sub Clause 16.4</b>	<p>The currencies for payments shall be:</p> <p>Pak. Rupees (for the services and goods being offered from within Pakistan).</p> <p>The amounts and currencies of the payment shall be in proportion to the amounts and currencies of the contract price.</p>
<b>GCC Sub Clause 18.1</b>	<p>Performance Security:</p> <p>The Supplier shall provide a Performance Security of 10% percent of the Contract Price. The Performance Security shall be denominated in the currency of the contract.</p>
<b>GCC Sub Clause 18.3</b>	<p>The Supplier shall provide a Performance Security in the prescribed Form annexed to these Documents in the form of Bank Guarantee from any Scheduled Bank in Pakistan.</p> <p>The cost of complying with the requirements of this Sub-Clause shall be borne by the Contractor.</p>
<b>GCC Sub Clause 18.4</b>	<p>Discharge of Performance Security shall take place not later than 28 days after Twelve (12) months from the date of FCS delivery</p>
<b>GCC Sub Clause 23.2</b>	<p>Packing, Marking and Documentation:</p> <p><b><u>Packing</u></b></p> <ol style="list-style-type: none"> <li>1. Packing of the Goods shall be as is required to prevent their damage or deterioration during transit to their final destination, as indicated in the Contract. The packing shall be sufficient to withstand, without limitation, rough handling during transit and exposure to extreme temperatures, salt and precipitation during transit, and open storage. Packing case size and weights shall take into consideration, where appropriate, the remoteness of the Goods' final destination and the absence of heavy handling facilities at all points in transit.</li> <li>2. In case the equipment is shipped in container(s), each unit shall be so packed that it can be safely transported by road/rail to ultimate destination in the country without disturbing the packing of other items.</li> </ol>

	<p>3. The final packing shall be such that the weight and dimensions of packages are within reasonable limits in order to facilitate handling, storage and transportation</p> <p>4. The packing, marking, and documentation within and outside the packages shall comply strictly with such special requirements as shall be expressly provided for in the Contract, including additional requirement, if any, and in any subsequent instructions ordered by the Purchaser.</p>
<p><b>GCC Sub Clause 24.1</b></p>	<p><b>Insurance</b></p> <p>The insurance coverage shall be in accordance with GCC Sub-Clause 24.1.</p> <p>For Goods to be provided from within the Purchaser’s Country, the Supplier must insure the Goods in the joint names of the Purchaser and the Supplier in an amount equal to <b>110%</b> of the EXW price of the Goods from warehouse to warehouse on all risks basis, including but not limiting to war risks, strikes, riot and civil commotion (SRCC), fire, smoke, explosion, terrorism, collision, overturn, derailment, flood, theft or attempted theft.</p> <p>Add the following new Sub Clause after 24.1:</p> <p>The insurance must remain in force for a period of ninety (90) calendar days after receipt of all Goods under the Contract at NGC’s designated storage yard, and conducting of insurance survey by the insurer. The Supplier shall arrange and pay for such insurance survey.</p> <p>The insurance shall be effected with National Insurance Company Limited (NICL), Pakistan. The terms of insurance shall be as approved by the Purchaser. A draft Insurance Policy shall be submitted by the Supplier within fourteen (14) days following signing of Contract Agreement, for approval by the Purchaser.</p> <p>Should a loss be sustained the Supplier shall replace or repair any loss or damage and complete the supplies of Goods in accordance with the Contract as soon as possible after such loss or damage without waiting for the settlement of the insurance claim.</p>
<p><b>GCC Sub Clause 26.1</b></p>	<p>a. The Supplier shall at its own expense and at no cost to the Purchaser arrange all such tests and /or inspections of the Goods as are specified in Section-IX. The Supplier shall provide free of charge all such assistance, instruments, machines, labor and materials as are normally required for carrying out such tests. All reasonable facilities as provided in the specifications or followed by Trade &amp; Industry in general</p>

	<p>shall have to be offered to the Inspecting officers, by you at your expense for carrying out Testing and Inspection.</p> <p>b. To ensure the manufacture of Goods to be in conformity with Contract requirements, the Supplier shall institute and follow regular procedures for quality assurance during manufacturing. The Supplier shall maintain an independent quality control department, which shall be responsible for enforcing the quality assurance programme. Upon Award of the Contract, the Supplier and the Engineer(s) shall establish mutually acceptable quality control and inspection procedure.</p>
<b>GCC Sub Clause 26.2</b>	(a) The supplied/ordered goods shall be inspected by two representatives, from the office of Chief Engineer (Asset Management North NGC, Multan.
<b>GCC Sub Clause 26.4</b>	<p>As soon as Goods are ready for inspection the Supplier shall give a notice in writing of fifteen (15) days for inspection to the inspectors with date, time and place at the following address:</p> <p style="padding-left: 40px;">Chief Engineer, Asset Management North NGC GSO House, Sher Shah Road, Cantt. Multan Telephone No. 92-61-9200515 Fax No. 92-61-9200516</p>
<b>GCC Sub Clause 26.6</b>	Two copies of all the Inspection and Tests Reports and certificates including that for-quality control shall be supplied to the Chief Engineer Asset Management North NGC, Multan. The Chief Engineer Asset Management North NGC, Multan or their two Nos. representatives/Inspectors shall countersign the reports and certificates of such test as have been witnessed.
<b>GCC Sub Clause 26.8</b>	The Purchaser's right to inspect, test and, where necessary reject delivery after the Good's arrival in Pakistan shall in no way be limited or waived by reasons of the Goods having previously been inspected, tested and passed prior to the Goods shipment from the country of origin.
<b>GCC Sub Clause 27.1</b>	The liquidated damage shall be 0.5 % of the total Contract Price per week or part thereof. The maximum amount of liquidated damages shall be ten percent (10%) of the Contract Price.
<b>GCC Sub Clause 28.1</b>	<p>Add the following at the end of GCC Sub Clause 28.1:</p> <p>The Supplier further warrants that all Goods supplied under this Contract shall have no defect arising from design, materials, or workmanship (except in so far as the design or material is required by the Purchaser's specifications) or from any act or omission of the Supplier that may develop under normal use of the supplied Goods in</p>

	the conditions prevailing on the country of final destination.
<b>GCC Sub Clause 28.3</b>	The warranty shall be valid for a period of 12 months from the date of FCS delivery
<b>GCC Sub Clause 28.5</b>	The Supplier shall correct any defects covered by the Warranty within 30 days of being notified by the Purchaser of the occurrence of such defects.
<b>GCC Sub Clause 30.1(b)</b>	The amount of aggregate liability shall be 110% of the contract price.
<b>GCC Sub Clause 33.2</b>	The purchaser may change the quantities of Goods to the extent of 15% of the Contract price during currency of the Contract without any change in the unit price or other terms and conditions of the Contract. No extension of time will be granted to the Contractor due to such variation order. Any variation above 15% will be open for negotiation for new prices.

**SECTION-VIII**  
**STANDARD FORMS**

# **STANDARD FORMS**

## **FORM OF BID SECURITY (Bank Guarantee)**

Security Executed on \_\_\_\_\_  
(Date)

Name of Surety (Bank) with Address: \_\_\_\_\_  
(Scheduled Bank in Pakistan)

Name of Principal (Bidder) with Address \_\_\_\_\_

Penal Sum of Security Rupees. \_\_\_\_\_ (Rs. \_\_\_\_\_)

Bid Reference No. \_\_\_\_\_

KNOW ALL MEN BY THESE PRESENTS, that in pursuance of the terms of the Bid and at the request of the said Principal (Bidder) we, the Surety above named, are held and firmly bound unto \_\_\_\_\_

(hereinafter called the 'Purchaser') in the sum stated above for the payment of which sum well and truly to be made, we bind ourselves, our heirs, executors, administrators and successors, jointly and severally, firmly by these presents.

THE CONDITION OF THIS OBLIGATION IS SUCH, that whereas the Bidder has submitted the accompanying Bid dated \_\_\_\_\_ for Bid No. \_\_\_\_\_ for \_\_\_\_\_ (Particulars of Bid) to the said Purchaser; and

WHEREAS, the Purchaser has required as a condition for considering said Bid that the Bidder furnishes a Bid Security in the above said sum from a Scheduled Bank in Pakistan or from a foreign bank duly counter-guaranteed by a Scheduled Bank in Pakistan, to the Purchaser, conditioned as under:

- (1) That the Bid Security shall remain in force up to and including the date 28 days after the deadline for validity of bids as stated in the Instructions to Bidders or as it may be extended by the Purchaser, notice of which extension(s) to the Surety is hereby waived;
- (2) That the Bid Security of unsuccessful Bidders will be returned by the Purchaser after expiry of its validity or upon signing of the Contract Agreement; and
- (3) That in the event of failure of the successful Bidder to execute the proposed Contract Agreement and furnish the required Performance Security, the entire said sum be paid immediately to the said Purchaser pursuant to Clause 19.6 of the Instruction to Bidders for the successful Bidder's failure to perform.

NOW THEREFORE, if the successful Bidder shall, within the period specified therefor, on the prescribed form presented to him for signature enter into a formal Contract with the said Purchaser in accordance with his Bid as accepted and furnish within twenty eight (28) days of his being requested to do so, a Performance Security with good and sufficient surety, as may be

required, upon the form prescribed by the said Purchaser for the faithful performance and proper fulfillment of the said Contract or in the event of non-withdrawal of the said Bid within the time specified for its validity then this obligation shall be void and of no effect, but otherwise to remain in full force and effect.

PROVIDED THAT the Surety shall forthwith pay the Purchaser the said sum upon first written demand of the Purchaser (without cavil or argument) and without requiring the Purchaser to prove or to show grounds or reasons for such demand, notice of which shall be sent by the Purchaser by registered post duly addressed to the Surety at its address given above.

PROVIDED ALSO THAT the Purchaser shall be the sole and final judge for deciding whether the Principal (Bidder) has duly performed his obligations to sign the Contract Agreement and to furnish the requisite Performance Security within the time stated above, or has defaulted in fulfilling said requirements and the Surety shall pay without objection the said sum upon demand from the Purchaser forthwith and without any reference to the Principal (Bidder) or any other person.

IN WITNESS WHEREOF, the above bounden Surety has executed the instrument under its seal on the date indicated above, the name and seal of the Surety being hereto affixed and these presents duly signed by its undersigned representative pursuant to authority of its governing body.

WITNESS:	SURETY (Bank) Signature _____
1. _____ _____	Name _____ Title _____
Corporate Secretary (Seal)	Corporate Guarantor (Seal)
2. _____ _____	
Name, Title & Address	

**FORM OF PERFORMANCE SECURITY  
(Bank Guarantee)**

Guarantee No. \_\_\_\_\_

Executed on \_\_\_\_\_

Expiry date \_\_\_\_\_

[Letter by the Guarantor to the Purchaser]

Name of Guarantor (Bank) with address: \_\_\_\_\_  
(Scheduled Bank in Pakistan)Name of Principal (Supplier/Contractor) with  
address: \_\_\_\_\_

Penal Sum of Security (express in words and figures) \_\_\_\_\_

Letter of Acceptance No. \_\_\_\_\_ Dated \_\_\_\_\_

KNOW ALL MEN BY THESE PRESENTS, that in pursuance of the terms of the Bidding Documents and above said Letter of Acceptance (hereinafter called the Documents) and at the request of the said Principal we, the Guarantor above named, are held and firmly bound unto the \_\_\_\_\_ (hereinafter called the Purchaser) in the penal sum of the amount stated above for the payment of which sum well and truly to be made to the said Purchaser, we bind ourselves, our heirs, executors, administrators and successors, jointly and severally, firmly by these presents.

THE CONDITION OF THIS OBLIGATION IS SUCH that whereas the Principal has accepted the Purchaser's above said Letter of Acceptance for \_\_\_\_\_  
\_\_\_\_\_ (Name of Contract) for the \_\_\_\_\_  
\_\_\_\_\_ (Name of Project).

NOW THEREFORE, if the Principal (Supplier/Contractor) shall well and truly perform and fulfill all the undertakings, covenants, terms and conditions of the said Documents during the original terms of the said Documents and any extensions thereof that may be granted by the Purchaser, with or without notice to the Guarantor, which notice is, hereby, waived and shall also well and truly perform and fulfill all the undertakings, covenants terms and conditions of the Contract and of any and all modifications of said Documents that may hereafter be made, notice of which modifications to the Guarantor being hereby waived, then, this obligation to be void; otherwise to remain in full force and virtue till all requirements of Clause 28, Warranty, of Conditions of Contract are fulfilled.

Our total liability under this Guarantee is limited to the sum stated above and it is a condition of any liability attaching to us under this Guarantee that the claim for payment in writing shall be received by us within the validity period of this Guarantee, failing which we shall be discharged of our liability, if any, under this Guarantee.

We, \_\_\_\_\_ (the Guarantor), waiving all objections and defenses under the Contract, do hereby irrevocably and independently guarantee to pay to the Purchaser without delay upon the Purchaser's first written demand without cavil or arguments and without requiring the Purchaser to prove or to show grounds or reasons for such demand any sum or sums up to the amount stated above, against the Purchaser's written declaration that the Principal has refused or failed to perform the obligations under the Contract which payment will be effected by the Guarantor to Purchaser's designated Bank & Account Number.

PROVIDED ALSO THAT the Purchaser shall be the sole and final judge for deciding whether the Principal (Contractor) has duly performed his obligations under the Contract or has defaulted in fulfilling said obligations and the Guarantor shall pay without objection any sum or sums up to the amount stated above upon first written demand from the Purchaser forthwith and without any reference to the Principal or any other person.

IN WITNESS WHEREOF, the above-bounden Guarantor has executed this Instrument under its seal on the date indicated above, the name and corporate seal of the Guarantor being hereto affixed and these presents duly signed by its undersigned representative, pursuant to authority of its governing body.

<p>Witness:</p> <p>1. _____</p> <p>_____</p> <p>Corporate Secretary (Seal)</p> <p>2. _____</p> <p>_____</p> <p>Name, Title &amp; Address</p>	<p>Guarantor (Bank)</p> <p>Signature _____</p> <p>Name _____</p> <p>Title _____</p> <p>_____</p> <p>Corporate Guarantor (Seal)</p>
--	--

## FORM OF CONTRACT AGREEMENT

THIS AGREEMENT made on the \_\_\_\_\_ day of \_\_\_\_\_, 20\_\_\_\_, between \_\_\_\_\_ of \_\_\_\_\_ (hereinafter “the Purchaser”), of the one part, and \_\_\_\_\_ of \_\_\_\_\_ (hereinafter called “the Supplier”), of the other part:

WHEREAS the Purchaser invited bids for certain Goods viz., \_\_\_\_\_ and has accepted a Bid by the Supplier for the supply of those Goods in the sum of \_\_\_\_\_ (hereinafter called “the Contract Price”).

NOW THIS AGREEMENT WITNESSETH AS FOLLOWS:

1. In this Agreement words and expressions shall have the same meanings as are respectively assigned to them in the Conditions of Contract hereinafter referred to.
2. The following documents shall be deemed to form and be read and construed as part of this Agreement, viz.:
  - (a) The Purchaser’s Notification to the Supplier of Award of Contract (Letter of Acceptance);
  - (b) The Form of Bid and the Price Schedules submitted by the Supplier;
  - (c) The Particular Conditions of Contract; Part-II
  - (d) The General Conditions of Contract; Part-I
  - (e) The Schedule to Bid (other than Price Schedule);
  - (f) Appendices to Bid;
  - (g) Specifications;
  - (h) Drawings; and
  - (i) Any other Item

This Contract shall prevail over all other Contract documents. In the event of any discrepancy or inconsistency within the Contract documents, then the documents shall prevail in the order listed above.

3. In consideration of the payments to be made by the Purchaser to the Supplier as indicated in this Agreement, the Supplier hereby covenants with the Purchaser to provide the Goods and to remedy defects therein in conformity in all respects with the provisions of the Contract.
4. The Purchaser hereby covenants to pay the Supplier in consideration of the provision of the Goods and the remedying of defects therein, the Contract Price or such other sum as may become payable under the provisions of the Contract at the times and in the manner prescribed by the Contract.

IN WITNESS the parties hereto have caused this Agreement to be executed in accordance with the laws of \_\_\_\_\_ on the day, month and year indicated above.

Signature of the Supplier

Signature of the Purchaser

\_\_\_\_\_  
(Seal)

\_\_\_\_\_  
(Seal)

Signed, Sealed and Delivered in the presence of:

Witness:

Witness:

\_\_\_\_\_  
(Name, Title and Address)

\_\_\_\_\_  
(Name, Title and Address)

**(INTEGRITY PACT)**

**DECLARATION OF FEES, COMMISSION AND BROKERAGE ETC.  
PAYABLE BY THE SUPPLIERS OF GOODS, SERVICES & WORKS IN  
CONTRACTS WORTH RS. 10.00 MILLION OR MORE**

Contract No. \_\_\_\_\_

Dated \_\_\_\_\_

Contract Value: \_\_\_\_\_

Contract Title: \_\_\_\_\_

..... [Name of Bidder] hereby declares that it has not obtained or induced the procurement of any contract, right, interest, privilege or other obligation or benefit from Government of Pakistan (GoP) or any administrative subdivision or agency thereof or any other entity owned or controlled by GoP through any corrupt business practice.

Without limiting the generality of the foregoing, [Name of Bidder] represents and warrants that it has fully declared the brokerage, commission, fees etc. paid or payable to anyone and not given or agreed to give and shall not give or agree to give to anyone within or outside Pakistan either directly or indirectly through any natural or juridical person, including its affiliate, agent, associate, broker, consultant, director, promoter, shareholder, sponsor or subsidiary, any commission, gratification, bribe, finder’s fee or kickback, whether described as consultation fee or otherwise, with the object of obtaining or inducing the procurement of a contract, right, interest, privilege or other obligation or benefit in whatsoever form from GoP, except that which has been expressly declared pursuant hereto.

[Name of Bidder] certifies that it has made and will make full disclosure of all agreements and arrangements with all persons in respect of or related to the transaction with GoP and has not taken any action or will not take any action to circumvent the above declaration, representation or warranty.

[Name of Bidder] accepts full responsibility and strict liability for making any false declaration, not making full disclosure, misrepresenting facts or taking any action likely to defeat the purpose of this declaration, representation and warranty. It agrees that any contract, right, interest, privilege or other obligation or benefit obtained or procured as aforesaid shall, without prejudice to any other rights and remedies available to GoP under any law, contract or other instrument, be voidable at the option of GoP.

Notwithstanding any rights and remedies exercised by GoP in this regard, [Name of Bidder] agrees to indemnify GoP for any loss or damage incurred by it on account of its corrupt business practices and further pay compensation to GoP in an amount equivalent to ten time the sum of any commission, gratification, bribe, finder’s fee or kickback given by [Name of Bidder] as aforesaid for the purpose of obtaining or inducing the procurement of any contract, right, interest, privilege or other obligation or benefit in whatsoever form from GoP.

Name of Purchaser: .....

Name of Bidder: .....

Signature: .....

Signature: .....

[Seal]

[Seal]

**SECTION-IX**

**SPECIFICATIONS-SPECIAL  
PROVISIONS**

# **TECHNICAL PROVISIONS AND SPECIFICATIONS**

## **1 GENERAL**

- 1.1 All design, equipment, material and workmanship shall comply with and be tested in accordance with requirements of the Specifications. Equipment or parts which are not covered by the Specifications, shall comply with approved National Standardizing bodies.
- 1.2 The general intent of these specifications is to require the supply of equipment and materials equal or superior to those actually described herein. Unless otherwise stated, reference to the brand or manufacture, if made is only for the sake of comparison as to type, design, character or quality of the equipment and materials desired and shall not be interpreted as eliminating other equipment and materials of equal performance quality and durability.
- 1.3 All questions arising as to the acceptability or other wise of the equipment and materials offered shall be decided by Chief Engineer (Asset Management) North, NGC, Multan whose decision shall be final.

## **2 UNITS OF MEASUREMENT**

- 2.1 All dimensions and units given by the Bidder in the Bid shall be in the form as specified in the schedule of technical data. Where not specified, all weights, measurements and quantities shall be metric units.

## **3 SPECIAL PROVISIONS**

- 3.1 The contract shall be executed in strict conformity with the specifications mentioned in this section and the supplier shall do no `Work` without proper specifications.
- 3.2 All the goods, the quantities of which are defined in Schedule of Prices for main equipment, shall be of the material in accordance with the Technical Specifications appended hereto.
- 3.3 Wherever reference is made in the Technical Specifications to specific standards and codes to be met by the goods and materials to be furnished or tested, the provisions of the latest current edition or revision of the relevant standards or codes in effect shall apply, unless otherwise expressly stated in the Contract. Where such standards and codes are national or relates to a particular country or region, other authoritative standards that ensure substantial equivalence to the standards and codes specified will be acceptable.

- 3.4 Goods and material specified in the Technical Specification must comply with standards cited or other recognized standards, which ensure an equal or higher quality than the standards mentioned.

#### **4.1 Specifications and drawings**

- i. The manufacturer/supplier shall submit to Employer within 30 days of the signing of the contract, for approval of the Employer, (3) copies of all drawings technical literature, data, operation and maintenance instruction books and/or manual required under the specifications and such other documents as required in the technical Specifications or other provisions of the Bidding Documents.
- ii. The Contractor/Manufacturer shall allow 07 days for the employer's approval of drawings in this schedule of work and in the time allowed for completion of the contract.
- iii. All drawings and documents furnished by the Contractor/Manufacturer in accordance with the contract shall become the property of the employer.
- iv. Offered Equipment must be delivered and installed at site. The installation charges shall be borne by the contractor.

#### **4.2. Inspection/Testing:**

The offered equipment shall be subject to inspection.

As soon as Goods are ready for inspection the Supplier shall give a notice in writing of fifteen (15) days prior for inspection to Chief Engineer (Asset management) North, NGC, Multan with date, time and place.

The inspector shall check carry out all the necessary visual checks & operational performance checks to demonstrate that the material meets the functional and performance requirements as specified in the Specifications.

The gas will be tested for weight, purity and dew point by the committee constituted by Chief Engineer (Asset management) North, NGC, Multan.

#### **5. Language**

- 5.1. All correspondence, literature, drawings, name plates, diagrams, applicable data, equipment details, instructions and maintenance books and manuals, spare parts, books and descriptive data shall be in the English language.

### **SUPPLEMENTARY INFORMATION**

#### **SI-01 ACQUAINTANCE WITH SITE**

The contractor shall inspect and examine the sites before delivery.

#### **SI-02 LOCATION OF SITE**

The location and name of sites are  
C-Type Store, 500KV Grid Station, NGC, Multan

**SI-03 TRANSPORTATION OF GOODS****General**

The Contractor shall be responsible for the loading, unloading and safe transportation of all goods / material required for completion of the contract/job as per scope of the tender. All the expenses in this context shall be borne by the contractor

**SI-04 SCHEDULE**

The contractor shall carry out the Work in accordance with the dates/ periods specified in General as well as Special Conditions of Contract and with the approved Schedule. In the said context, the contractor shall submit a final schedule to NGCL within 07 days of signing of contract.

**SI-05 SITE FACILITIES AND SERVICES**

Attention is drawn to the obligations of the supplier/manufacturer to make his own arrangements at his own expense for Services or facilities provided to his employees. Any cost incurred by the supplier/manufacturer in respect of any of such Site facilities or services under the Contract shall be deemed to be included in the rates and prices in the Price Schedule and no separate payment, therefore, will be made to the supplier/manufacturer. Therefore, it is the responsibility of the supplier/manufacturer to visit the site during the tender phase and to familiarize himself with conditions related to it. If the location of the site is not indicated in the Supplementary Specification, it can be obtained from the Department. No claim for additional payment related to ignorance of site conditions will be accepted. By submitting a tender, it is accepted that the supplier/manufacturer is fully aware of all site conditions as well as the access to it, and has allowed for this in their tender price.

## **TECHNICAL PROVISIONS AND SPECIFICATIONS**

Item No	Description of Goods/Stores	A/U	Technical Specification / Design Reference
1.	Shirt (Deep Sky Blue)	No	SD-1 to SD-4
2.	Trouser (Navy Blue)	No	SD-5 to SD-7
3.	Shoes Black (DMS Sole) Ankle Height	Pair	SD-8
4.	Jersey woolen Full Sleeve (Navy Blue)	No	SD-12 to SD-13
5.	Jacket (Navy Blue)	No	SD-10 to SD-11
6.	Vest Cotton Half Sleeves (White)	No	SD-17
7.	Cold Weather Vest Full Sleeve and Trousers (Legging)	Pair	
8.	Beret Cap (Maroon)	No	SD-15
9.	Socks Nylon (Black) Double Knit	Pair	SD-14
10.	Cap Badge (NGC) (Aluminum Alloy Silver color)	No	SD-25
11.	Shoulder Title (NGC SECURITY) (Aluminum Alloy Silver color)	Pair	SD-24
12.	Arm Shield (NGC) (2.5" Diameter)	No	SD-9
13.	Lanyard (Maroon) + Whistle	No	SD-22
14.	Rank Sgt (Red with two black lines)	No	SD-16
15.	Rank Inspector (Aluminum Alloy Silver color)	Set	SD-26
16.	Rain Coat (Navy Blue)	No	SD-18 to SD-19
17.	Gloves Woolen (Navy Blue)	Pair	SD-21
18.	Belt Nylon (Black) + Plate & Badge (52")	No	SD-23
19.	Cap Comforter Woolen (Navy Blue)	No	SD-20

**Note:**

The pattern, sewing, stitching and material of the offered Goods shall be as per the specifications and design pattern given. The quality and workmanship shall be of superior standard. Parameters that would be considered as a minimum for quality assessment of samples are given at Annexure-A. The sizing chart is available at Annexure-B.

**SD-1****TECHNICAL DATA - CLOTH SHIRTING (DEEP SKY BLUE)**

1. Weight per Sq Mtr : 200 gms  $\pm$ 10 gms
2. Material Composition
  - a. Polyester : 65%  $\pm$  5%
  - b. Cotton : 35% (Balance)
3. Weave : 1/1 Plain
4. Thread per inch
  - a. Warp : 76  $\pm$  2 (Each 2 Fold)
  - b. Weft : 60  $\pm$  2 (Each 2 Fold)
5. Count of Yarn
  - a. Warp : 2/36  $\pm$  5% ECC
  - b. Weft : 2/36  $\pm$  5% ECC
6. Shrinkage (Maximum)
  - a. Warp : 2 %
  - b. Weft : 2 %
7. Nature of Dyes : Disperse / Vat
8. Scouring Loss (Maximum) : 1%
9. Crease Recovery : Wrinkle Resistant
10. Static Charges : Cloth should not develop static Charges.
11. Shade : Deep Sky Blue (As per standard pattern)
12. Feel & Finish : Mercerized Sanforized
13. The cloth shall be woven with the yarn uniformity spun and twisted, free from neps, knots and other spinning defects like contamination with fly (fibers) of other material causing development of slubs / streaks of different shade in cloth.

SD-2

SHIRT (DEEP SKY BLUE)

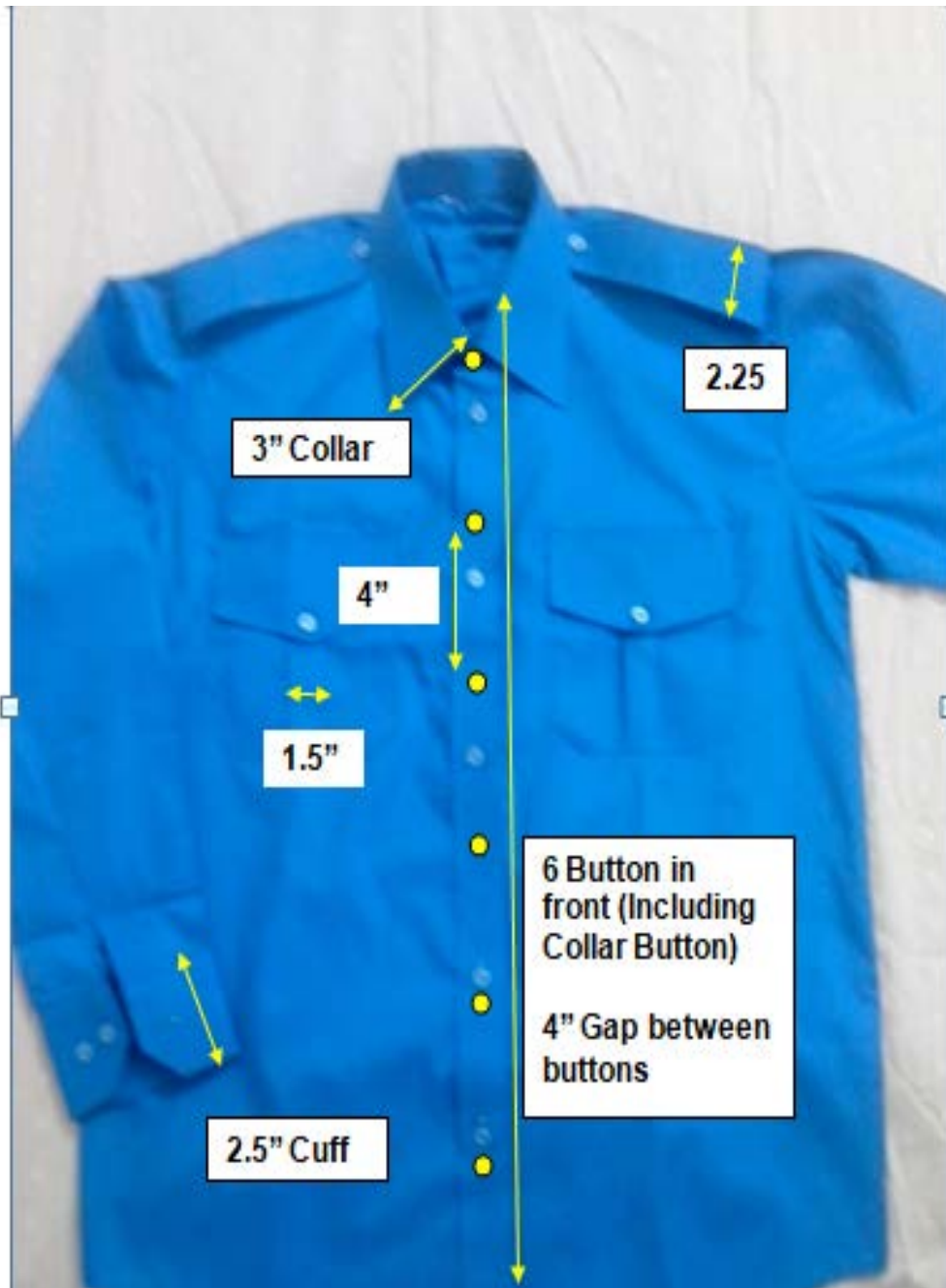

SD-3

CUFF

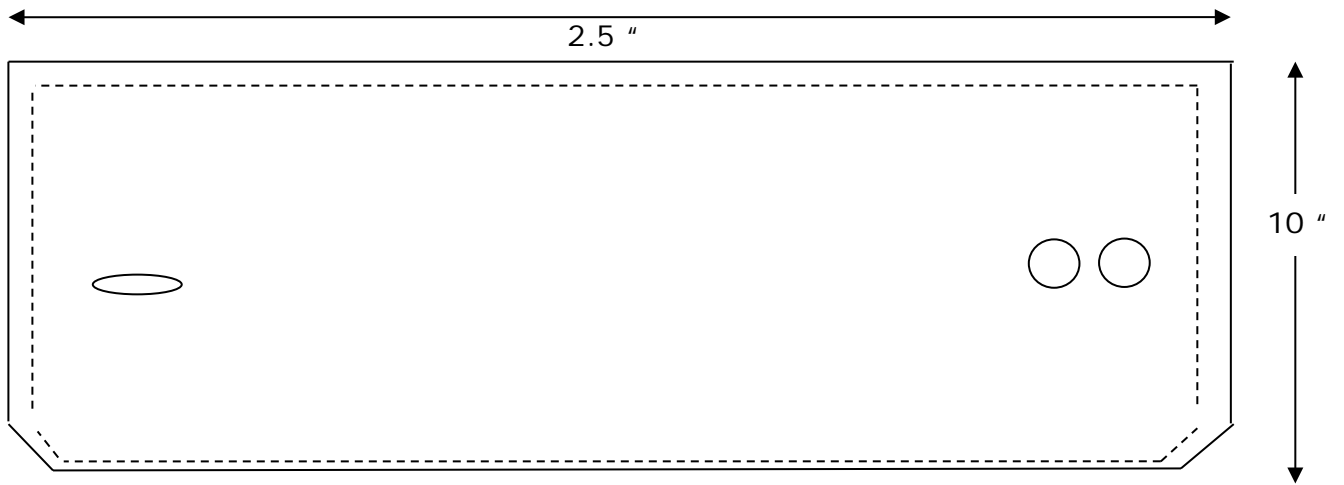

COLLAR

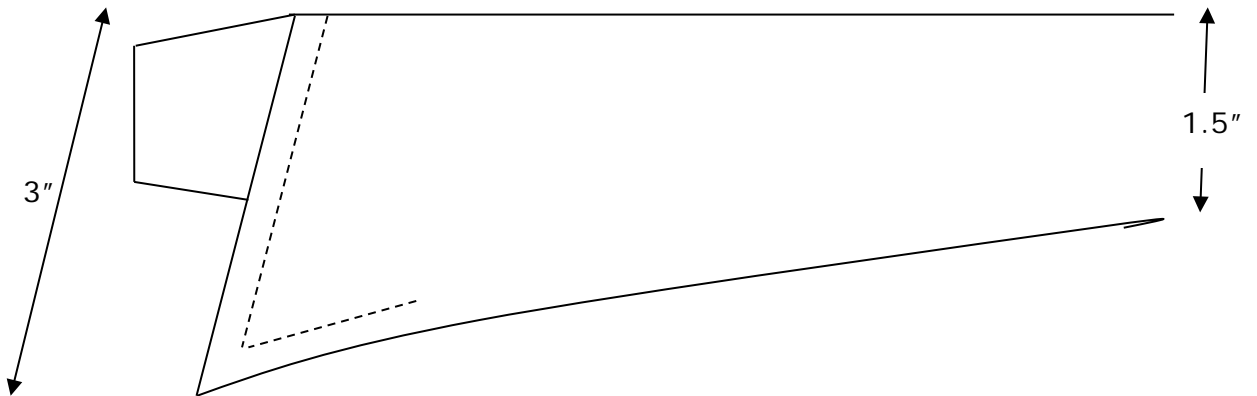

SD-4

SHIRT POCKETS

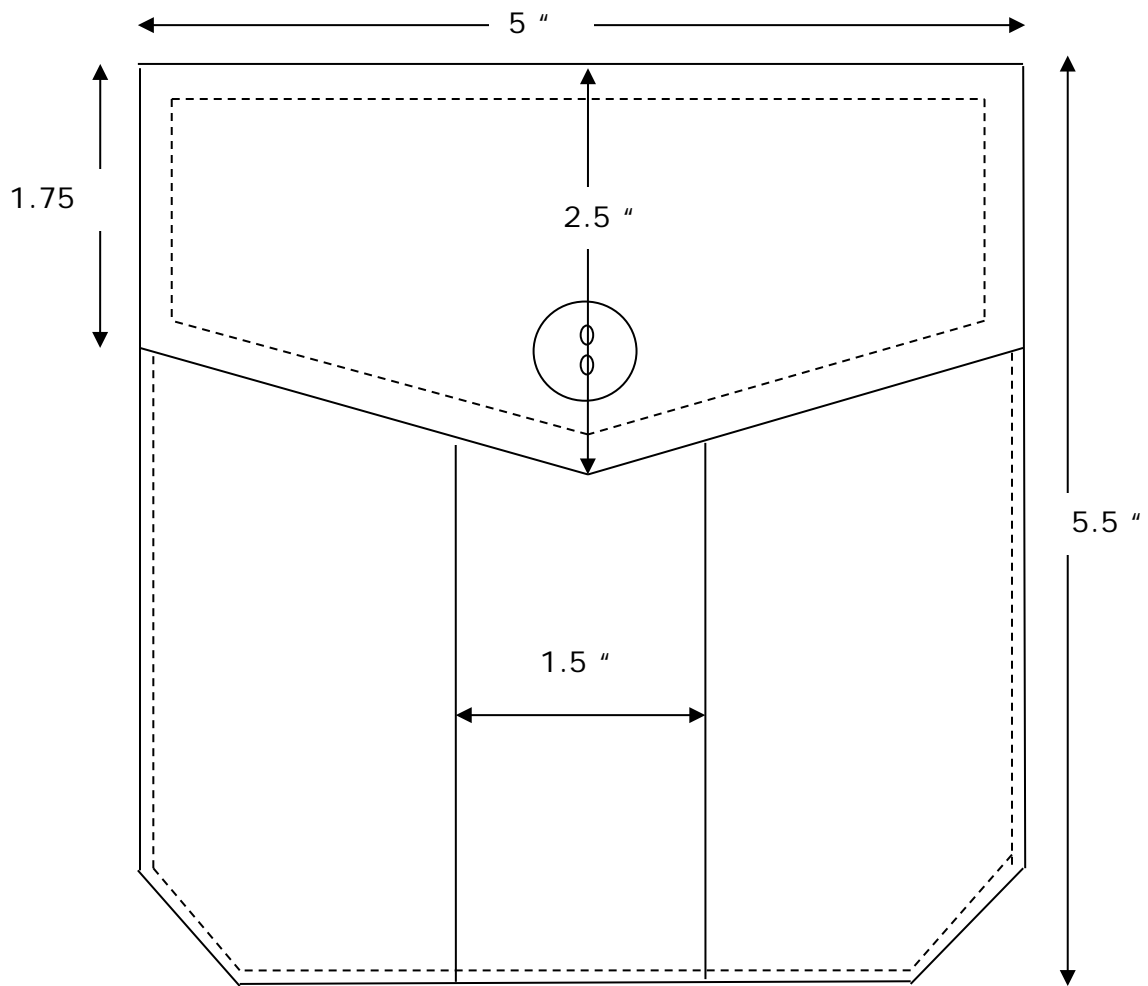

**SD-5****TECHNICAL DATA CLOTH TROUSERS (NAVY BLUE)**

1. Width (Including selvedge) : 57"±1"
2. Wt/Sq Mtr : 250 gms ±10 gms
3. Material Composition
  - a. Polyester : 65% ± 5%
  - b. Cotton : 35% (Balance)
4. Weave : 1/1 Twill
5. Thread per inch
  - a. Warp : 82 ± 2
  - b. Weft : 68 ± 2
6. Count of Yarn
  - a. Warp : 2/30 ± 5% ECC
  - b. Weft : 2/30 ± 5% ECC
7. Shrinkage (Maximum)
  - a. Warp : 2 %
  - b. Weft : 2 %
8. Nature of Dyes
  - a. Polyester : Disperse
  - b. Cotton : Vat
9. Scouring Loss (Maximum) : 1%
10. Crease Recovery
  - a. Warp / Weft : Not less than 75%
11. Shade : Navy Blue
12. Special Finish
  - a. Easy Care (Wrinkle Free)
  - b. Soil Release
13. Static Charges : Cloth should not develop static charges.

14. Ironing
  - a. The cloth should not bleed color on wet cloth during ironing.
  - b. The cloth should not shine with ironing
15. The cloth shall be woven with the yarn uniformity spun and twisted, free from neps, knots and other spinning defects like contamination with fly (fibers) of other material causing development of slubs / streaks of different shade in cloth.
16. Unless specified in purchase order the length of trouser will be of free size.

SD-6

**TROUSER (NAVY BLUE)**

- 1. Fly with : 3 Buttons
- 2. Belt : 2.00" Wide
- 3. Belt Loop : 4.25" Long
- 4. Note : All the Stitching must be over-locked

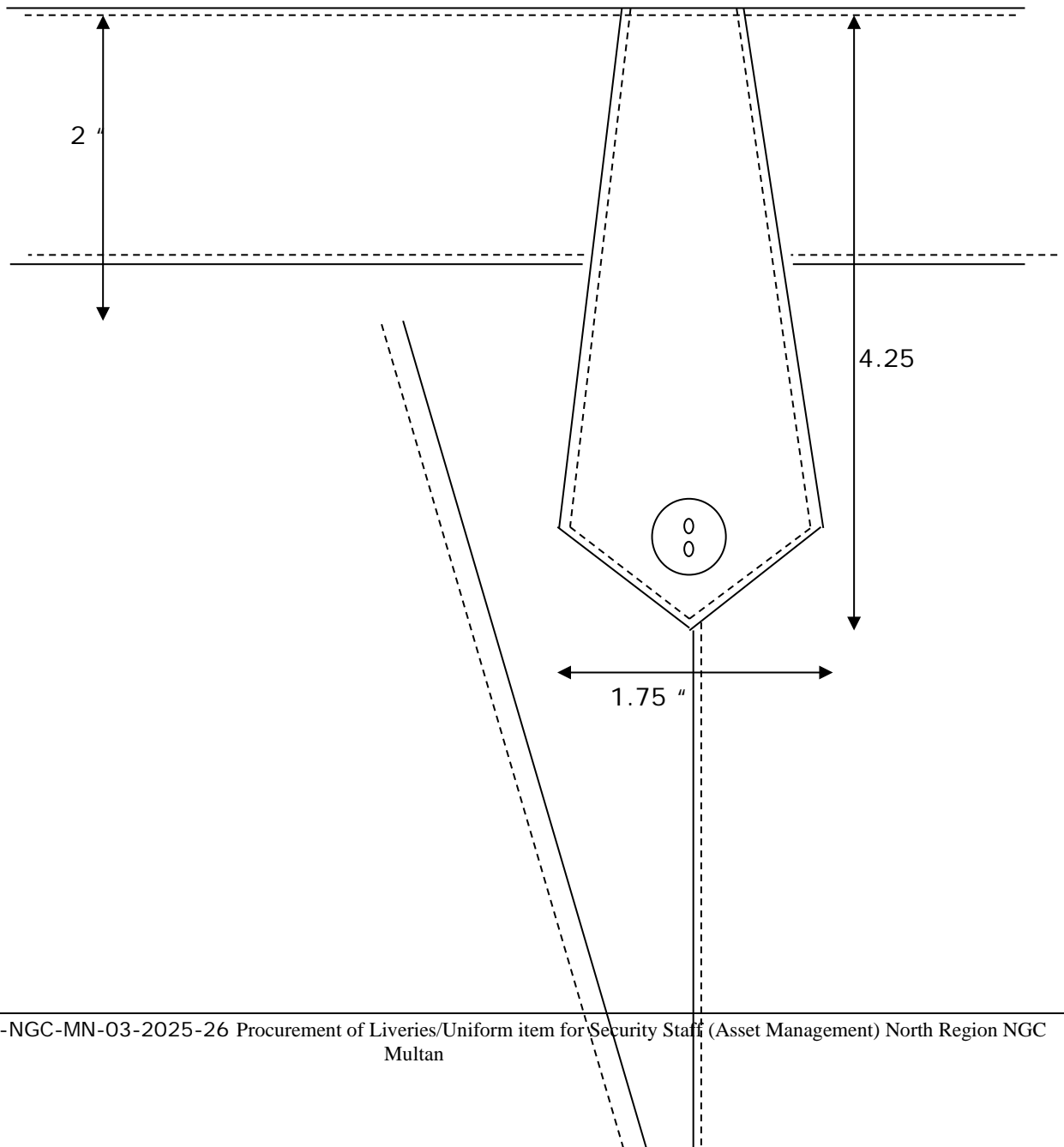

SD-7

**TROUSER (NAVY BLUE)**



SD-8

**SHOES**

1. Material : Cow leather
2. Sole : Rubber
3. Type : DMS Sole
4. Pattern : Ankle Height
5. Colour : Black
6. Length of Laces : 24"
7. Thickness of Laces : 4mm (Round shape)
8. Material of Laces : Nylon (Unbreakable & black colour)



**SD-9****ARM SHIELD (NGC)**

Diameter : 2.5 inch

Safety Pin for Wearing on Sleeve of the Shirt/Jersey



**SD-10****TECHNICAL DATA - JACKET**

1. Type : Reflective Warm Jacket
2. Length : 32 inch (For Large size only)
3. Width : 26 inch (For Large size only)
4. Upper Pocket : (Length 6.5 inch & Width 5.75 inch)
5. Lower Pocket : (Length 8.5 inch & Width 7.0 inch)
6. Filling : Polyester sheet
7. Inner Lining : Silk
8. Colour : Navy Blue
9. Tightening tool : Cords
10. Cuff : Velcro + Button

SD-11

JACKET (NAVY BLUE)  
(With tightening cords)



**SD-12****TECHNICAL DATA - JERSEY WOOLEN (NAVY BLUE)**

1. **Composition of material**
  - a. Wool : 60% ± 3%
  - b. Acrylic : 32% ± 2%
  - c. Polyester : 08% (Balance)
  
2. **Composition of Blended material**
  - a. Wool : 70%
  - b. Acrylic : 30%
3. Type of Yarn : Double
4. Quality of Wool : 64 (21.1 – 22.5 microns)
5. Quality of Acrylic : Regular
6. Knitting of Body : 02 plies of 70% Wool and 30% of Acrylic
7. Knitting of Border and Cuff : 03 plies of 70% Wool and Acrylic with double elastic at the edge.
8. Re-enforcement inside the chest : Weight / Sq mtr = 250±15 gms  
and elbow (Cloth 100% polyester)
9. Shade : Navy Blue
10. Shoulder Flaps : The Jersey should have two shoulder Straps 5cm at the base tapering to 3.75cm at the end.
11. Buttons : Button round (13 mm dia) plastic blue grey with sewing holes.
12. The Jersey shall have a "V" shaped neck fitted with 2/2 rib attached by linking machine and not over locked.
13. The sleeve shall have re-enforcement patch at elbow position of shape and design in the drawing and made from 100% polyester cloth. The patch shall be stitched with double rows of stitching all round.
14. The sleeve shall not be very loose from any part of the arm.
15. The Jersey shall not have pocket bags.
16. The Jersey have two pocket flaps having a button hole, button and stitch buttons at inner side at edges of flaps. The flaps shall be made from knitted fabric of the same material and lined with 100% polyester cloth.
17. The Dyed Jersey shall show no change in shade or any sign of staining on to the attached pieces of Nylon and Woolen material when subjected to washing.

**SD-13**

**JERSEY WOOLEN FULL SLEEVE (NAVY BLUE)**

Note: 10 " Blue Zeen Cloth on Elbow of Jersey Sleeves

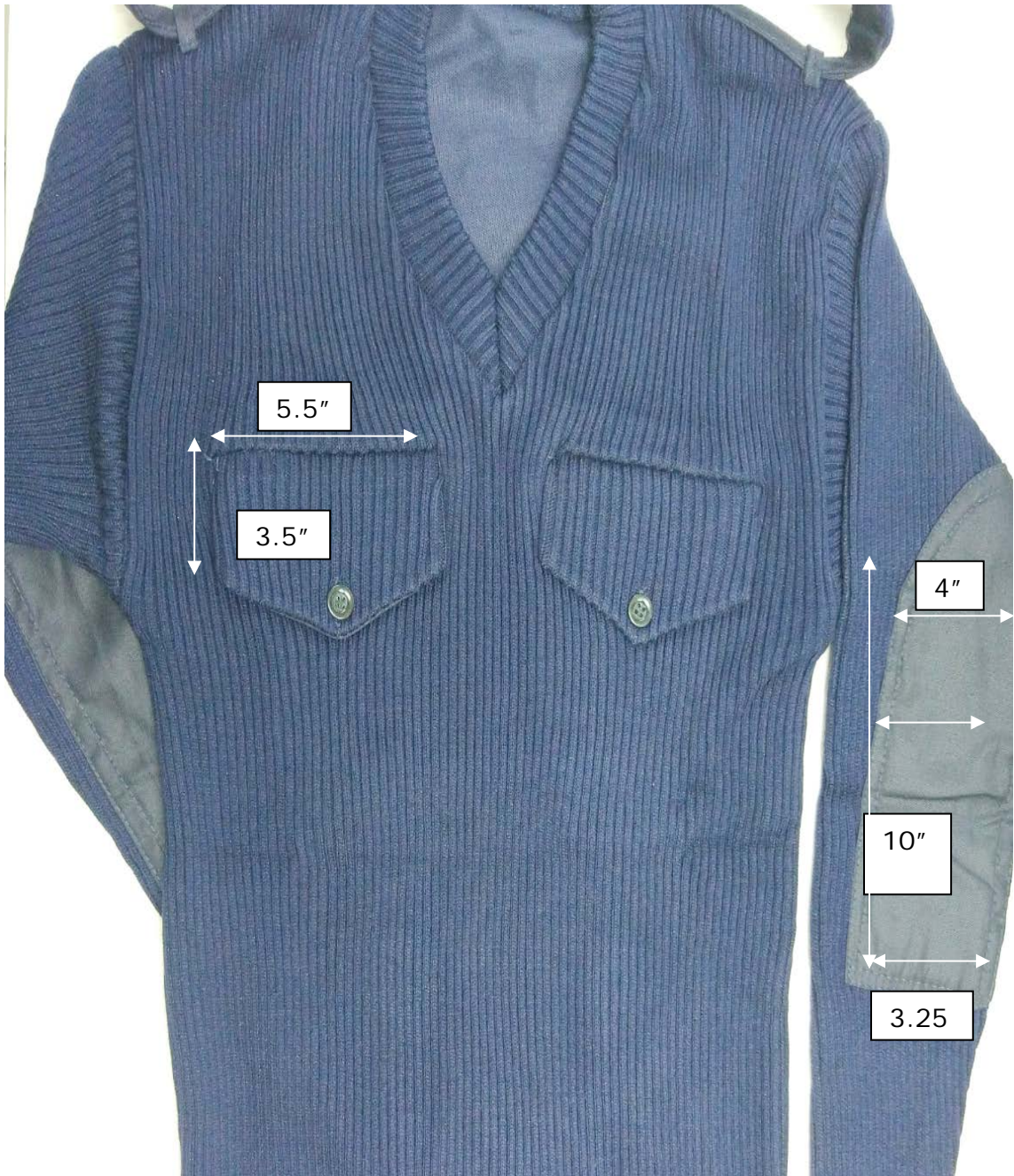

SD-14

Socks Nylon (Black) Double Knit

Weight = 28 g (Single) 56 g (Pair)



**SD-15**

**BERET CAP (MAROON)**

(as per demanded sizes)



**SD-16**

**RANK SERGEANT (RED WITH TWO BLACK LINES)**



**SD-17****TECHNICAL DATA - VEST COTTON H/SLEEVES (WHITE)**

1.	Weight per Sq Mtr	:	130 gms $\pm$ 10 gms
2.	Material Composition	:	Cotton 100%
3.	Count	:	32 ECC
4.	Yarn Twist (TPI)	:	22 $\pm$ 1
5.	Thread per inch		
	a. Wales	:	37 $\pm$ 2
	b. Course	:	45 $\pm$ 2
6.	Shrinkage (Maximum)		
	a. Length	:	20 mm
	b. Chest	:	20 mm
7.	Sewing Cotton	:	4 cord each single0
8.	Finishing	:	Full Bleached

**SD-18****TECHNICAL DATA RAIN COAT (NAVY BLUE)**

1. Material : Polyester or Nylon Fabric coated with Silicon from inside
2. Weight : 150 to 170 GSM
3. Seam : Rugged Heat Sealed
4. Length : 46 inch
5. Width : 26 inch
6. Cap height : 12 inch

SD-19

RAIN COAT (NAVY BLUE)



**SD-20****TECHNICAL DATA - CAP COMFORTER WOOLEN (NAVY BLUE)**

1.	Material	:	Wool 100% $\pm$ 2
2.	Quality of Wool	:	60 S to 64 S
3.	Stitching Thread	:	Nylon/Polyester
4.	Length	:	30 Inch
5.	Width	:	09 Inch
6.	Weave	:	9 line per inch
7.	Total Wieght	:	127.5 gram



**SD-21****TECHNICAL DATA - GLOVES WOOLEN (NAVY BLUE)**

1. Material : Wool 100%  $\pm$  2
2. Quality of Wool : 60 S to 64 S
3. Stitching Thread : Nylon/Polyester
4. Length : 9.5" Medium Size
5. Width : 5 " (4 Fingers without Thumb)
6. Weave : 06 Lines per inch
7. Wiegth : 29 g (Single)



**SD-22****LANYARD (MAROON) + WHISTLE**

1. Length of Lanyard : 23 inch
2. Width of Lanyard : 1.5 inch
3. Material of whistle : Steel



**SD-23****BELT NYLON (BLACK )+ PLATE & BADGE (52")**

1. Length : 52"
2. Front Plate : 3 " x 2.5" with NGC Metal Badge (Chrome Plated)
3. Plate : Steel Chrom Plated
4. Badge : Aluminum Alloy (Silver Colour)
5. Eyelet Holes : 20
6. Plate+Badge : 71 g



**SD-24****SHOULDER TITLE (NGC SECURITY) (METALLIC)**

1. Width : 2.00"
2. Height : 0.80"
3. Weight : 6.6 g (Single)
4. Material : Aluminum Alloy
5. Colour : Silver



**SD-25****CAP BADGE (NGC) (METALLIC)**

1. Height : 1.60"
2. Width : 1.40"
3. Weight : 16 g
4. Material : Aluminum Alloy
5. Colour : Silver



**SD-26**

**RANK INSPECTOR (METALLIC)**

**(WITH SIGN NGC SECURITY)**

1. Material : Aluminum Alloy
2. Colour : Silver

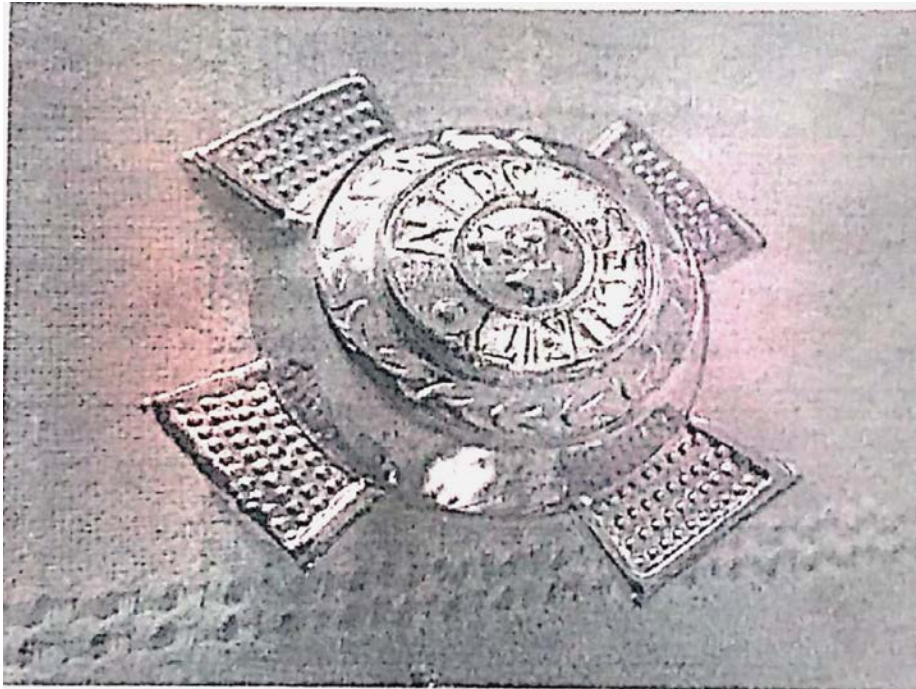

## Annexure-A

Description of Store/Goods	Parameters
Item #1: <b>Shirt (Deep Sky Blue)</b> & Item # 2: <b>Trouser (Navy Blue)</b>	Quality of cloth
	Stitching
	Shine
	Colour
	Over locking
	Edging
	Quality of Buttons
	Sewing Thread
	Finishing
Item # 3: <b>Shoes Black (DMS Sole) Ankle Height</b>	Quality of leather
	Shine
	Colour
	Laces
	Bonding
	Flexibility of sole
	Stitching
Flexibility of leather	
Item # 4: <b>Arm Shield (NGC) (2.5" Diameter)</b>	Quality of cloth
	Stitching
	Colour
	Size accuracy
	Safety Pin
Item #5: <b>Jacket (Navy Blue)</b>	Quality of cloth
	Stitching
	Shine
	Colour
	Over locking
	Edging
	Quality of Buttons
	Sewing Thread
	Reflector strips
	Tightning Cord
	Quality of Fur
	Inner Liner

	Quality of Zip
<i>Item#6:</i> <b>Jersey woolen Full Sleeve (Navy Blue),</b>  <i>Item #13:</i> <b>Cap Comforter Woolen (Navy Blue),</b>  <b>&amp;</b>  <i>Item #14</i> <b>Gloves Woolen (Navy Blue)</b>	Quality of wool
	Stitching
	Stretching of cuffs
	Colour
	Over locking
	Edging
	Quality of Buttons
	Sewing Thread
	Stretching of waist line
Flexibility	
<i>Item#7:</i> <b>Socks Nylon (Black) Double Knit</b>	Quality of material
	Stitching
	Colour
	Sewing Thread
	Stretching
<i>Item# 8:</i> <b>Beret Cap (Maroon)</b>	Quality of cloth
	Stitching
	Shine
	Colour
	Quality of Rim
	Edging
	Back of Badges (leather)
	Sewing Thread
Foam	
<i>Item#9:</i> <b>Rank Sgt (Red with two black lines)</b>	Quality of cloth
	Finishing
	Shine
	Colour
	Accuracy of size
<i>Item#10:</i> <b>Vest Cotton Half Sleeves (White),</b>  <i>Item#11:</i> <b>Cold Weather Vest Full Sleeve and Trousers (Legging)</b>	Quality of cloth
	Stitching
	Shine
	Colour
	Over locking
	Edging
	Sewing Thread
Stretching /flexibility	
<i>Item#12:</i> <b>Rain Coat (Navy Blue)</b>	Quality of cloth
	Stitching

	Shine
	Colour
	Waterproofing
	Quality of Buttons/Zip
	Sewing Thread
<i>Item#15:</i> <b>Lanyard (Maroon) + Whistle,</b>	Quality of cord
	Shine
<i>Item#16:</i> <b>Belt Nylon (Black )+ Plate &amp; Badge (52")</b>	Colour
	Quality of metal
	Legth
<i>Item#17:</i> <b>Shoulder Title (NGC SECURITY) (Metallic),</b>	Finishing
	Weight
<i>Item#18:</i> <b>Cap Badge (NGC) (Metallic)</b>	Shine
	Colour
<i>Item#19:</i> <b>Rank Inspector (Metallic)</b>	Quality of metal

## Annexure-B

Item #	Description of Stores/Goods	Size	Quantity
1.	Shirt (Deep Sky Blue)	S	55
		M	723
		L	1091
		XL	1184
		XXL	941
		XXXL	318
2.	Trousers (Navy Blue)	S	55
		M	723
		L	1091
		XL	1184
		XXL	941
		XXXL	318
3.	Shoes Black (DMS Sole) Ankle	38	83
		40	272
		41	394
		42	552
		43	484
		44	293
4.	Jersey Woolen Full Sleeve (Navy blue)	S	30
		M	385
		L	616
		XL	596
		XXL	435
		XXXL	94
5.	Jacket (Navy Blue)	S	63
		M	426
		L	631
		XL	583
		XXL	453
6.	Vest Cotton Half Sleeves	S	200
		M	843
		L	1448
		XL	1119
		XXL	702
7.	Cold Weather Vest Half Sleeves	S	5
		M	23
		L	71

		XL	41
		XXL	19
8.	Beret Cap Maroon	20	154
		21	727
		22	810
		23	465