

**Government of Pakistan
Ministry of Water Resources
Pakistan Council of Research in Water Resources**



Tender Document

**General Maintenance Works of PCRWR Building and Associated
Infrastructure**

Submission deadline:

3rd June, 2026 (Wednesday)

**Khayaban-e-Johar, Near Edhi Homes, H-8/1, Islamabad
Ph: 051-9101282- Fax: 9101280,**

GENERAL INFORMATION ABOUT THE CONTRACTOR/FIRM

Name of Firm: _____

Main Line or Business: _____

Type of Organization: _____

National Tax Number: _____

General Sales Tax Number: _____

Status of Active Tax Payer: _____

Registration No. with PEC with date of Expiry:

Phone No(s): _____ **Fax No.** _____

Email: _____

Mailing address: _____

Contact Person/Name of Authorized Representative: _____

**SIGNATURE & SEAL
OF
CONTRACTOR/FIRM**

TERMS AND CONDITIONS

1. General

- i. Sealed bids under (Single Stage-One Envelope) bidding procedure are invited under PPRA Rules 2004 on item rates basis from the firms/companies registered with Income/Sales Tax departments who are on active tax payers list of FBR as well as valid registration with Pakistan Engineering Council in category C-4 and above with relevant codes CE-09 & CE-10.
- ii. The said work will be executed at the premises of PCRWR building located at H-8/1, Islamabad and its R&D Farm located at Dar Kali Kalan, Gujjar Khan, Rawalpindi. The document can also be downloaded from PCRWR website (www.pcrwr.gov.pk) and PPRA Website.
- iii. Bids (Technical & Financial) must be accompanied with Earnest Money equivalent amounting to Rs.1,265,657/- in the form of demand draft/pay order in favor of the **Chairman, PCRWR, Islamabad**. Unsealed bids, bids without earnest money would be rejected out rightly. The earnest money will be forfeited if a bidder(s) withdraws his bid(s) during the period of his bid(s) validity. The earnest money of unsuccessful bidder(s) will be returned to them after award of work to the successful bidder.
- iv. The last date of submission of bids is upto 11:00 AM on 3rd June, 2026 (Wednesday). The bids will be opened at 11:30 AM on the same day, in the presence of the bidders or their representatives.
- v. The bidders are required to submit hard copies of the technical and financial bids encompassing the item wise rates against each item.
- vi. Lowest rates by a firm will not construe towards winning of bid and award of work. The bids will be evaluated both on technical and financial criteria encompassed at Sr # 10 of this document. Based on the final evaluation, the work will be awarded to the successful bidder.
- vii. The Competent authority reserves the right to reject all bids or proposals at any time prior to the acceptance of a bid or proposal as per the PPRA rule 33(1).
- viii. Bids with cutting or overwriting will not be accepted.
- ix. Bids filled with lead pencil will not be accepted.
- x. Conditional/incomplete bids will not be accepted.
- xi. Quoted price must be inclusive of all taxes having validity for 6 months from the date of tender opening.

- xii. The bidder shall ensure that the bid is complete in all respects. To manage and install missing accessories/works (if any) for complete functionality would be the obligation of the bidder within the offered cost.
- xiii. The Technical specifications of the bid are at Annexure-I while the drawings of the works to be executed are at Annexure-II to Annexure-XIII.

2. Bid Pricing and Quoting

The bidder shall indicate, in his/her offer the unit prices inclusive of all taxes (supply, transportation, installation) and total bid prices of the services/goods. Payment of any taxes, duties, etc. levied before or after opening of bids by the Government shall be the full responsibility of the bidder(s) subject to prevailing regulations. The prices shall be quoted in Pakistan rupees only. The person signing the bid shall initial all the pages of the bid(s) where entries are made. Prices charged by the supplier for goods delivered and services performed under the contract shall not exceed from the prices quoted by the supplier in its bid(s). No bid received after the prescribe deadline will be entertained and will be rejected without caring the reasons for delayed receipt in even due to negligence of the postal/courier services etc.

3. Purchaser's Right

PCRWR reserves the right to reduce/increase the quantity or cancel this tender, prior to award of contract, thereby evolving no financial liability whatsoever or any other obligation on the part of PCRWR from the side of bidders. No other sub-office (outfit) of PCRWR is authorized to collect bid(s), only PCRWR Head Office is authorized to do so.

4. Conversing

No bidder shall contact Engineer/Employer on any matter relating to its bid from the time of the bid opening to the time the bid evaluation result is announced by the Employer. The evaluation result shall be announced prior to award of Contract. Any effort by a bidder to influence Engineer/Employer in the bid evaluation, bid comparison or contract award decisions may result in the rejection of his/her bid. Whereas, any bidder feeling aggrieved may lodge a written complaint not later than fifteen (15) days after the announcement of the bid evaluation result, however, mere fact of lodging a complaint shall not warrant suspension of procurement process.

5. Performance Guarantee

The successful bidder(s) is/are required to furnish a performance guarantee in the shape of a demand draft or a CDR, equivalent to 10% of the total contract amount within ten days of issuance of supply order/award of contract. Performance

guarantee/security will be forfeited in case of failure to successfully complete the performance period of 1 year after completion of the works. The withheld performance security will be returned after successful completion of the guarantee period.

6. Specified Terms

The bidder shall complete the aforementioned works within **180 days** from the date of issuance of work order. A penalty @ 0.01% of the quoted price per day will be charged after expiry of the said period.

7. Mode of Payment

- a) 10% mobilization advance will be made against the work order to facilitate the successful bidder in mobilization to the site. Payment shall be made in the form of cross-cheque.
- b) 40% payment will be made after Interim Milestone/Running Account Bill (e.g., 50%) completion of works after verification of designated engineer.
- c) 50% payment will be made upon successful completion, inspection, final handover subject to verification of designated engineer.
- d) Failure to supply of items/services against supply/work order will lead to confiscation of the earnest money and the performance guarantee.

8. PCRWR Responsibility

Coordinate and collaborate with the contractor about all the technical aspects of the project components.

9. Award/Evaluation Criteria

The bids would be evaluated based upon following:

➤ **Technical soundness (60%)**

- 30 marks for relevant past experience

The bidder will provide past performance along with supporting documents (work orders and performance certificates) and current commitments for technical scrutiny. (These may be verified by the client).

- a Projects of similar nature completed over last 03 years specifically of retrofitting
- b Working Capital in last 3 years with reference to bank statement

- 30 marks for relevant Human Resource

The bidder will provide details of the relevant manpower and machinery on judicial stamp paper required to carry out the said tasks.

- 25 marks for relevant machinery. (Detail of machinery should also be attached with the document)
- 05 marks for SECP registration
- 05 marks for PEC registration
- 05 marks for FBR registration

The bidder obtaining 70% or more marks in technical soundness will qualify for financial bidding.

➤ **Financial Soundness (40%)**

- Lowest price: 100 marks
- 2nd lowest: 95 marks
- 3rd lowest: 90 marks

Further lowest bidder will be ranked with 5 less marks in descending order with 10 marks being the lowest

The representative of Chairman, PCRWR or his designated Field Engineer, may examine any item, equipment, material, supplies and/or services to be provided under this contract, at any time prior to expiry of this contract. He may reject or require alteration there to or replacements thereof as a condition of acceptance and its findings shall be conclusive except in regard to defects or fraud which may appear later.

- Accomplishment and/or execution of each item of work (total or a part thereof) shall be considered subject to the verification of Field Engineer designated by the Competent Authority for work accomplishment.

Annexure-I**TECHNICAL SPECIFICATIONS**

S #	Item Description	Unit	Tentative Quantity	Estimate Unit Rate (Rs.)	Bid Rate (Rs.)	Amount (Rs.)	Bid Amount (Rs.)
1.	Preparing the surface and painting i/c rubbing the surface with Bathy (silicon carbide rubbing brick) filling the voids with zink /chalk / plaster of paris mixture, applying first coat premix, making the surface smooth and then painting 2 coats with emulsion of approved make etc: complete (old surface). (ICI or Berger or equivalent)	Sft.	97,500	74.25		7,239,375	
2.	Preparing and applying Graffito/ graphic to wall Surface to provide durable crust and having water fire and termite resistance (upto 5"- 0 height)	Sft	7,500	121.50		911,250	
3.	1/2" (13 mm) thick cement plaster 1:4 on walls and columns etc. in basement, foundation, plinth, mezzanine and ground floor including making edges, corners, and curing etc., complete.	Sft	15,000	60.75		911,250	
4.	Painting guard bars, gates of iron bars, gratings, railing, doors and similar open works with oil paint	Sft	11,000	162.00		1,782,000	
5.	Removal of existing plaster	Sft	3,500	33.75		118,125	
6.	Stone cladding/Tukri of required size of upto 5 ft on wall facing of approved design shape and pattern set in Tile Bond/cement sand mortar ratio 1:2 in gray cement 3/4" thick in/c washing of joints with net white cement salary and pigment in desire shape in/c cutting and dressing the stone tile to proper profile in/c labour etc and including complete packing with angle irons, complete as per specification as directed by the Engineer / Incharge.	Sft	8,350	418.50		3,494,475	
7.	Providing and laying 3" 1/2" thick mosaic flooring consisting of 1/2" mosaic topping of one part of cement and marble powder/Padlow Powder in the ratio 3:1 and to two part of marble chips (8 No.) laid over 4" thick flooring of 1:3:6 cement concrete including rubbing, panel dividing (3ftx3ft) and polishing complete alongwith 4"x1/2" skirting.	Sft	17,500	384.75		6,733,125	
8.	Providing and laying Tuff Paver having 7000 psi crushing strength (Izhar or equivalent). 60 mm thick, over 1" sand cushion and " cement concrete having ratio 1:4:8 i/c grouting with sand in joints i/c finishing to regulate slope, in pattern as approved by Engineer, complete in all aspects alongwith kerbing.	Sft	10,500	378.00		3,969,000	
9.	Providinf and laying of P.C.C (1:4:8) for wheelcahir ramp and walkway	Cft	5,120	480.60		2,460,672	
10.	Constructing manhole or inspection chamber of 2.5ftx2.5ft and 4ft depth with walls of R.C.C 1:2:4 i/c fixing C.I manhole cover with frame of clear opening 2' x 2' of 4.5 cwt. embedded in 9" thick R.C.C 1:2:4 i/c fixing duly painted etc	No.	6	62,100.00		372,600	
11.	Constructing manhole or inspection chamber of 4ftx5ft and 8ft depth with walls of R.C.C 1:2:4 i/c fixing C.I manhole cover with frame of clear	No.	2	121,500.00		243,000	

	opening 2' x 2' of 4.5 cwt. embedded in 9" thick R.C.C 1:2:4 i/c fixing duly painted etc					
12.	Constructing manhole or inspection chamber of 1ft x 1ft and 1.5ft depth with walls of R.C.C 1:2:4 i/c fixing C.I manhole cover with frame of clear opening of 4.5 cwt. embedded in 9" thick R.C.C 1:2:4 i/c fixing duly painted etc	No.	7	28,350.00		198,450
13.	Providing and laying of concrete foundation 1:2:4 for parking shed poles with plaster including required excavation for the foundation complete in all aspects	Cft	38	810.00		30,780
14.	Drain using brick work having dimensions of 1.5ft x 1ft for rainwater alongwith plaster and making & fixing grating in opening including fixing at site with flat iron of 14 Gauge complete in all aspects.	Rft	350	2,970.00		1,039,500
15.	Dismantling of tiles upto 5 ft and Safe removal and disposal of all waste and rubble.	Sft	8,000	121.50		972,000
16.	Removing door with G.I. chowket.	No.	8	9,450.00		75,600
17.	Dismantling of Aluminum partition walls of 7ft in the washroom	Rft	400	351.00		140,400
18.	Dismantling of European toilets, WCs and accessories Safe removal and disposal of all waste and rubble.	Nos.	15	4,050.00		60,750
19.	Dismantling of squatting toilets, WCs and accessories Safe removal and disposal of all waste and rubble.	Nos.	11	4,725.00		51,975
20.	Providing and laying superb quality (Grade AAA) Ceramic tiles dado of Master/Stile brand or approved equivalent manufacturer of size 12"x24", Glossy/Matt/Texture skirting/dado of approved Color and Shade with adhesive bond over 1/2" thick (1:2) cement plaster i/c the cost of sealer for finishing the joints i/c cutting grinding complete in all respects as approved and directed by the Engineer Incharge	Sft	6,400	641.25		4,104,000
21.	Providing and fixing squatting type white glazed earthen ware W.C. pan with front flush inlet & complete with including the cost of flushing cistern with internal fitting and flush pipe with bend and making requisite number of holes in walls, plinth & floor for pipe connection & making good in cement concrete 1:2:4. (Foreign Quality) (19 inch) earthen ware trap and plastic thumble (ICL or equivalent).	Nos.	11	14,850.00		163,350
22.	Providing and fixing European type white glazed earthen ware wash down W.C. pan complete with & including the cost of white / black plastic seat (Best quality) and lid with C.P. brass hinges best quality and buffers 3 gallons white glazed earthen ware low level flushing cistern with siphon fitting 1½ " dia white porcelain enameled flush bend dia and making requisite number of holes in walls , plinth & floor for pipe connection & making good in cement concrete 1:2:4 (Foreign quality) (ICL or equivalent).	Nos.	15	36,450.00		546,750
23.	Providing and fixing of G I 16 gauge chowkats of 2.5ft x 7ft x 1/2ft	Nos.	11	10,800.00		118,800
24.	Providing and fixing of G I 16 gauge chowkats of 3.5ft x 7ft x 1/2ft	Nos.	11	14,175.00		155,925

25.	Supplying & Fixing in Position 1/2" dia brass Bib cock (standard pattern)	Nos.	60	1,620.00		97,200	
26.	Supplying & fixing C.P muslim shower with double bib cock and ring pipe etc. complete	Nos.	35	4,725.00		165,375	
27.	Providing and fixing 24x18" lavatory basin in white glazed earthen ware complete with & including the cost of W.I. or C.I. cantilever bracket 6 inches built into wall, painted white in two coats after a primary coat of red lead paint, a pair of 1/2" dia chrome plated pillar taps, 1-1/2" rubber plug & chrome plated brass chain 1-1/4" dia malleable iron or C.P. brass traps malleable iron or brass unions and making requisite number of holes in walls, plinth & floor for pipe connection & making good in cement concrete 1:2:4 (Standard Pattern) (ICL or equivalent)	Nos.	20	11,475.00		229,500	
28.	Providing and fixing towel rail 24"x3/4" round or with brackets screws nuts & cleats etc. complete	Nos.	12	2,160.00		25,920	
29.	Providing and fixing C.P. brass toilet paper brackets complete (similar) to twyford design number 1108 (Superior Quality)	Nos.	35	2,430.00		85,050	
30.	Providing & fixing 24"x18" bavelled edge mirror of Belgium glass completed with 1/8" thick hard - and C.P. screws fixed to wooden cleats (Standard pattern).	Nos.	20	2,970.00		59,400	
31.	Supplying & fixing soap tray (plastic) of superior quality and design with fine finishing with C.P. screws etc. complete	Nos.	20	945.00		18,900	
32.	Fixing dismantled Aluminium structure for walls partition along with the aluminum cladding.	Rft	250	270.00		67,500	
33.	Air ventilation duct having dimensions 2ft x 1ft of PVC boards 12mm for washroom exhaust alongwith cutting, fittings and fans complete in all aspects.	Rft	60	2,025.00		121,500	
34.	Dismantling of existing brick structure with cement mortar, roof chips and roof slabs alongwith safe disposal of the waste.	Cft	500	270.00		135,000	
35.	Dismantling of existing Iron frame shed having CG iron sheet roof and glass walls and Safe removal and disposal of all waste and rubble.	Sft	765	283.50		216,877.5	
36.	Providing and laying brick (1 st Class) walling in ground floor walls, in foundation and plinth with cement mortar (1:4) as specified in the attached drawings	Cft	4,330	445.50		1,929,015	
37.	Providing and laying of concrete foundation 1:2:4 for foundation complete in all aspects	Cft	300	2,227.50		668,250	
38.	Water Tank (2000 litres) of High Density Polyethylene (HDPE) Food Grade Layer: 5x Layers Height: 64.5". Width: 53.5" Brass Nozzle with Air Tight Lids and fittings complete in all aspects.	Nos.	1	49,275.00		49,275	
39.	Brass valves 25mm for gas connections	Nos.	6	3,375.00		20,250	
40.	Supplying & fixing in position Aluminum channels framing for sliding windows (4ft x 4ft) of made with 5 mm thick tinted glass glazing (Belgium) & Aluminum fly screen l/c handles stoppers & locking arrangement etc.	Nos.	9	37,800.00		340,200	

41.	Supplying & fixing in position Aluminum channels framing for ventilators (2ft x 2ft) of made with 5 mm thick tinted glass glazing (Belgium) l/c handles stoppers & locking arrangement etc. including exhaust fan 12"	Nos.	2	14,850.00		29,700	
42.	Grill for the windows of 25mm thickness and 14 gauge bars (6ft x 4ft) 4" bar to bar distance	Nos.	9	20,250.00		182,250	
43.	R.C.C (1:2:4) work (shingle 1/8" to 3/4" gauge.) in roof slab, beams, column, rafts, lintels and with reinforcement bar Grade 60 No.4 spacing as per design other structural members i/c shuttering complete in all respects.	Cft	2,480	3,375.00		8,370,000	
44.	uPVC pipe for supply of water from tank to washrooms of 1" Inch dia complete with all accessories i/c union valves for flow control (Popular/Master or equivalent)	Rft	150	364.50		54,675	
45.	Providing and fixing of 6" dia uPVC pipe for waste/rainwater drainage, including jointing solution, elbows, tees, clamps, and cutting/fixing in walls/supports. (Popular/Master or equivalent)	Rft	150	1,755.00		263,250	
46.	Providing and fixing of 4" dia uPVC pipe for waste/rainwater drainage, including jointing solution, elbows, tees, clamps, and cutting/fixing in walls/supports. (Popular/Master or equivalent)	Rft	150	945.00		141,750	
47.	Pure Copper Wire 3/29 (2 core)	Roll	13	29,700.00		386,100	
48.	Pure Copper Wire 7/29 (2 core)	Roll	9	45,900.00		413,100	
49.	Pure Copper Wire 7/36 (4mm) (4 core)	Roll	5	105,300.00		526,500	
50.	Pure Copper Wire 7/52 (10mm) (4 core)	Roll	1	310,500.00		310,500	
51.	Providing & fixing Circuit Breaker triple point (100 amp) Terra or equivalent	Nos.	2	24,300.00		48,600	
52.	Providing & fixing Circuit Breaker (10 amp) Terra or equivalent	Nos.	10	1,890.00		18,900	
53.	Providing & fixing Circuit Breaker (20 amp) Terra or equivalent	Nos.	10	2,835.00		28,350	
54.	Providing & fixing Stainless steel box for circuit breakers	Nos.	2	10,125.00		20,250	
55.	Electric Switches – Pure White, 6 Gang + Socket with Dimmer including iron boxes	Nos.	25	6,075.00		151,875	
56.	Providing & fixing U-PVC Electrical Conduit Pipe 1" for wiring with necessary accessories complete in all aspects	Rft	600	337.50		202,500	
57.	U-PVC Electrical Conduit Pipe 1.5" for wiring with necessary accessories complete in all aspects	Rft	100	1,080.00		108,000	
58.	Providing & fixing Fan box	Nos.	14	810.00		11,340	
59.	Providing & fixing Multi Light plug with box complete	Nos.	25	1,215.00		30,375	
60.	Providing & fixing Noiseless Exhaust fan (2 Way) 12" royal fan or equivalent	Nos.	5	12,150.00		60,750	
61.	Providing & fixing Noiseless Exhaust fan 6" royal fan or equivalent to be fitted in glass ventilators	Nos.	5	4,995.00		24,975	
62.	Providing & fixing 40 WATT Double LED Tube Light (white) (4ft) with joint box (4 way) Osaka or equivalent	Nos.	40	4,050.00		162,000	
63.	Providing & fixing street lights 100 watts having IP65 classification with 100w lamp, choke, capacitor & internal wiring complete in all respect upto the height up 30 ft	Nos.	12	94,500.00		1,134,000	

64.	Providing & fixing Ceiling Fans-56" copper-(White) with fan box royal or equivalent	Nos.	12	15,525.00		186,300	
65.	Providing & fixing UPVC door having dimensions 3.5 ft x 7 ft and thickness of 28mm with handles	Nos.	9	95,850.00		862,650	
66.	Providing & fixing UPVC door having dimensions 2.5 ft x 7 ft and thickness of 28mm with handles	Nos.	5	67,500.00		337,500	
67.	Providing & fixing 10 Inch Stainless Steel Interior/exterior Door Aldrop (Kundi) With 3 Knuckles (superior quality) with padlocks and nut bolts etc.	Nos.	10	2,025.00		20,250	
68.	Providing & fixing 8 inch Stainless Steel Tower Bolt with nut bolts etc.	Nos.	12	1,215.00		14,580	
69.	Providing & fixing of MS tabular pole to be fixed on pre-cast foundation with the help of hydraulic crane & manual labour. 15 ft (6" dia) 8 SWG Base plate 18 x 18" x 3/4" Hole 4 no's stiffeners 4 nos 9 1/2" x 4 1/2"x1/2" Making window in the pole required size with LN key provision Two coats red oxide (2coat) as rust preventive & of required oil paint (2 coats) as per site requirement & instruction of EI with provisions of underground wirings.	Nos.	4	33,750.00		135,000	
70.	Safe dismantling of existing gas supply pipe (2" dia) and reassembling after civil works are executed.	Rft	150	877.50		131,625	
71.	Providing and fixing high strength, corrosion resistance, and lightweight aluminium frame having thickness of 4mm, Frame Widths 65mm x 65mm, Powder-coated, anodized, concealed fastening, featuring insulation strips and PVC Wall Panels of size 11 ft length and 1-inch thickness alongwith doors and locks complete in all aspects.	Sft	1,200	675.00		810,000	
72.	Providing and laying knitted tufted woven Polypropylene carpet (rectangular) 4 ft x 12ft green color alongwith underneath softening foam.	Nos.	4	4,050.00		16,200	
73.	Dismantling of wooden stage and disposal of rubble	Cft	225	283.50		63,787.5	
74.	Providing & fixing false ceiling of pvc panels of required design and size including frame work etc: complete in all aspects.	Sft	1,000	472.50		472,500	
75.	Providing and fixing of recessed LED lights in false ceiling of 7W, 40K WH complete in all aspects.	Nos.	24	2,700.00		64,800	
76.	Constructing concrete abulation platforms and benches (32mm terrazzo or 1:2:4 PCC) and applying waterproof plaster (1:3 cement/sand with additives Fillets)	Cft	23	1,053.00		24,219	
77.	Providing and laying heavy-duty, slip-resistant ceramic or porcelain floor tiles (400mmx400mm or similar) Grade AAA and wall tiles with high-strength epoxy grout. & Providing concrete fillets at wall-floor joints and installing drainage channels.	Sft	90	1,350.00		121,500	
78.	Providing and fixing Wuzu Faucet (CP Wall Type, Press Action and Water Pipe PPR PN-16/20 (Dadex/Polydex or equivalent) complete in all aspects	Nos.	4	8,100.00		32,400	
79.	Shifting of Container rooms having dimensions (5ft x 5ft x 7ft) through crane and placing at specified spots withing 100 meters	Nos.	2	16,200.00		32,400	

80.	Supply and application of Danna lacquer and Spirit Polish gloss finish and sealer (First quality) Nippon, ICI or equivalent) after cleaning of surfaces with mineral spirits and a soft cloth, ensuring the surface is dry and free of wax. On furniture including office tables, book racks and wooden almirahs and chairs.	Nos.	500	9,450.00		4,725,000	
81.	Supply and changing of existing fabric on office chairs and sofas including foam (4" full Gauge) with 15 year warranty and springs first quality imported. For sofas the tair putti of 2". Repair of springs (first quality imported). in the seat cushions wherever required of same fabric and wear and tear to be rectified including ball fibre, glue complete in all aspects.	Nos.	150	16,200.00		2,430,000	
Total (Rs.)						63,282,816	
Bid Amount (Rs.)							

Amount in Words: _____

**Sign and Seal
of
Contractor/Firm**

Date: _____

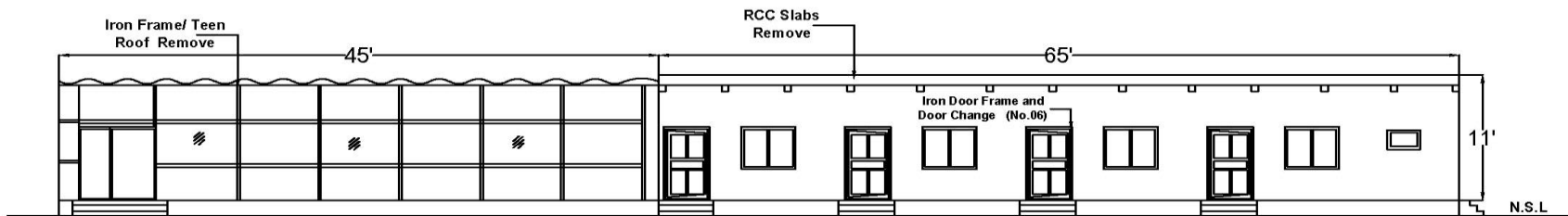

EXISTING STRUCTURE/ GROUND FLOOR ELEVATION

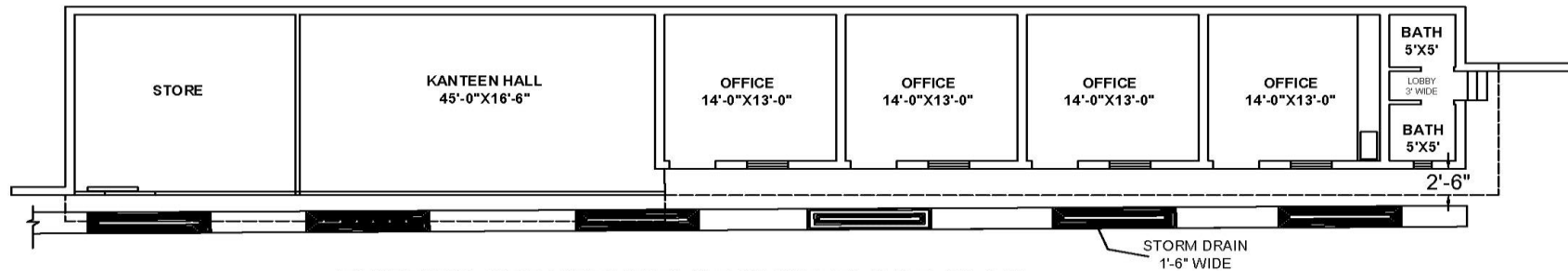

EXISTING STRUCTURE/ GROUND FLOOR PLAN

PCRWR-SDO-2026

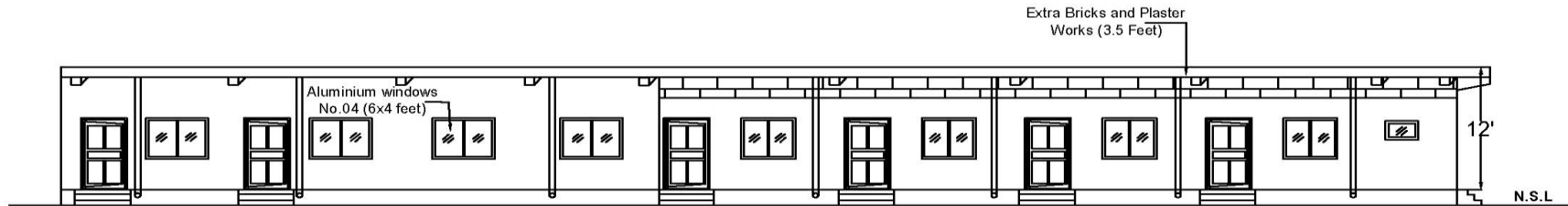

PROPOSED STRUCTURE/GROUND FLOOR ELEVATION

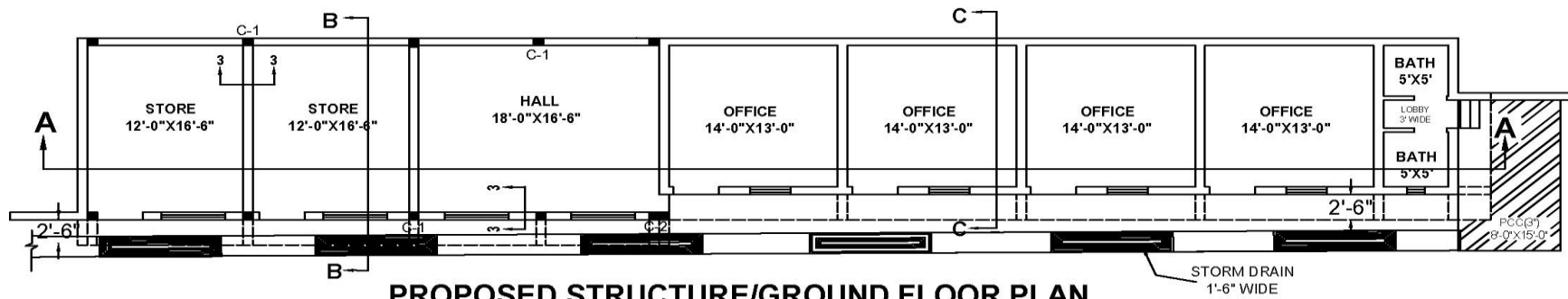

PROPOSED STRUCTURE/GROUND FLOOR PLAN

PCRWR-SDO-2026

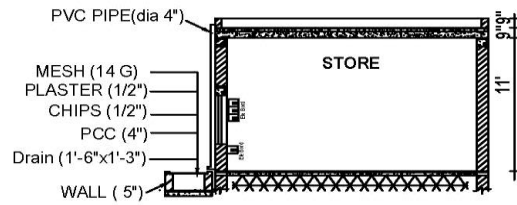

SECTION B-B

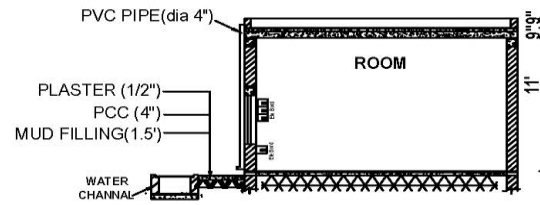

SECTION C-C

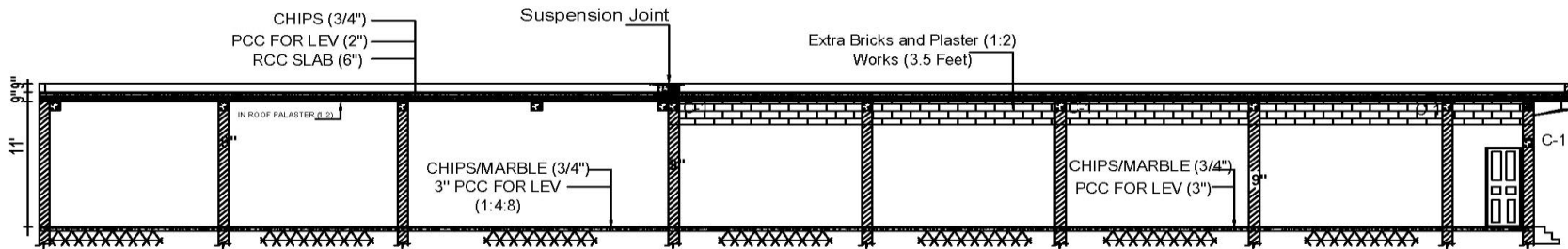

SECTION A-A

PCRWR-SDO-2026

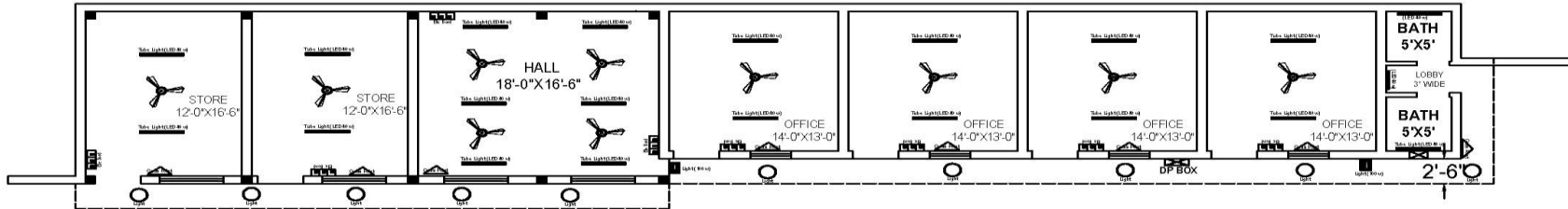

PROPOSED ELECTRICAL- GASS GROUND FLOOR PLAN

PCRWR-SDO-2026

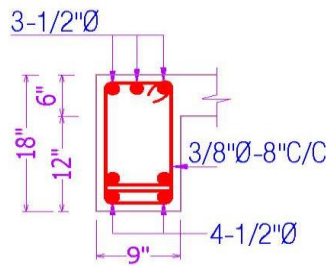

X. SECTION OF C-2

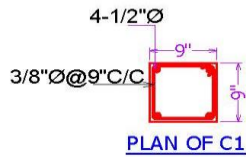

PLAN OF C1

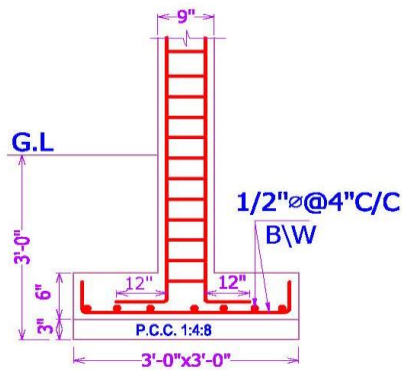

X SECTION AT A-A

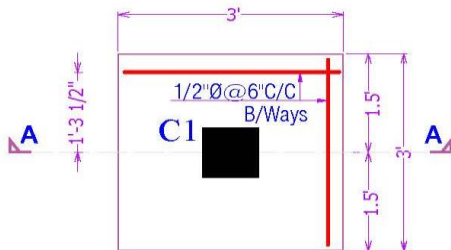

PLAN OF F-1

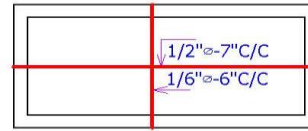

SLAB REINFORCEMENT PLAN OF ROOM (BOTTOM BARS)
SLAB = 6"

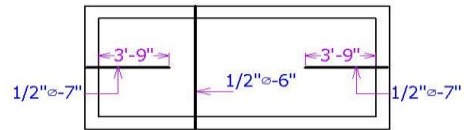

SLAB ROOM (TOP BARS)
SLAB = 6"

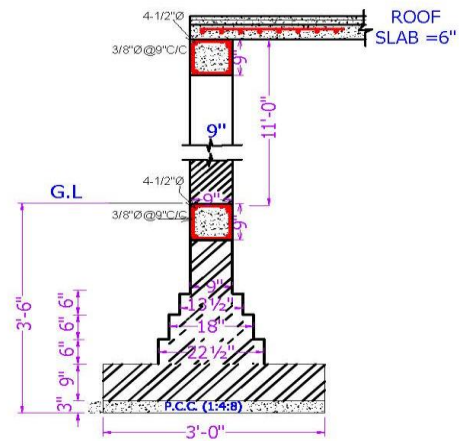

SECTION AT 3-3

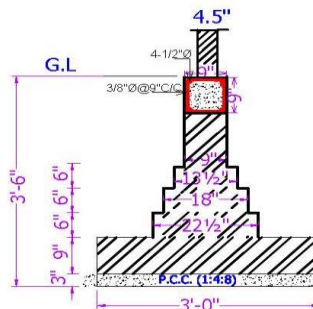

SECTION AT 2-2

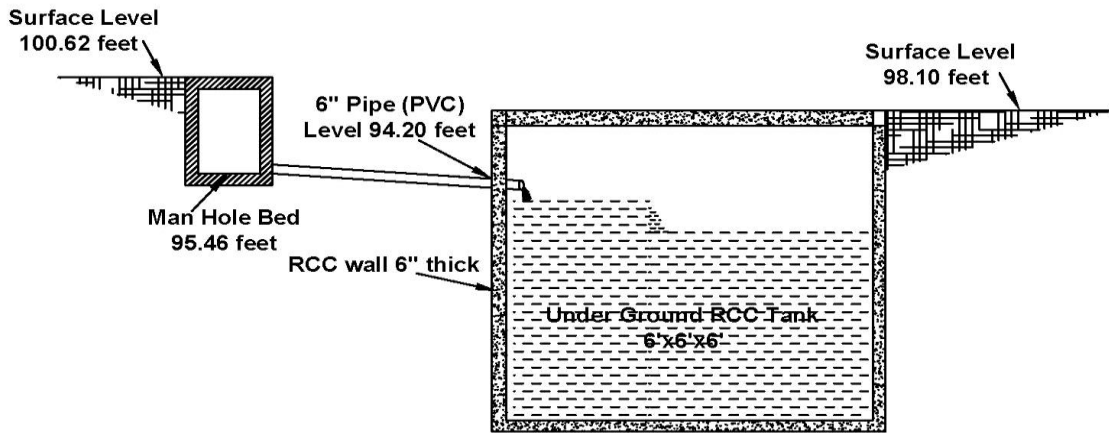

**EXISTING STRUCTURE WETLAND TANK
(HYBRID) UNDER GROUND**

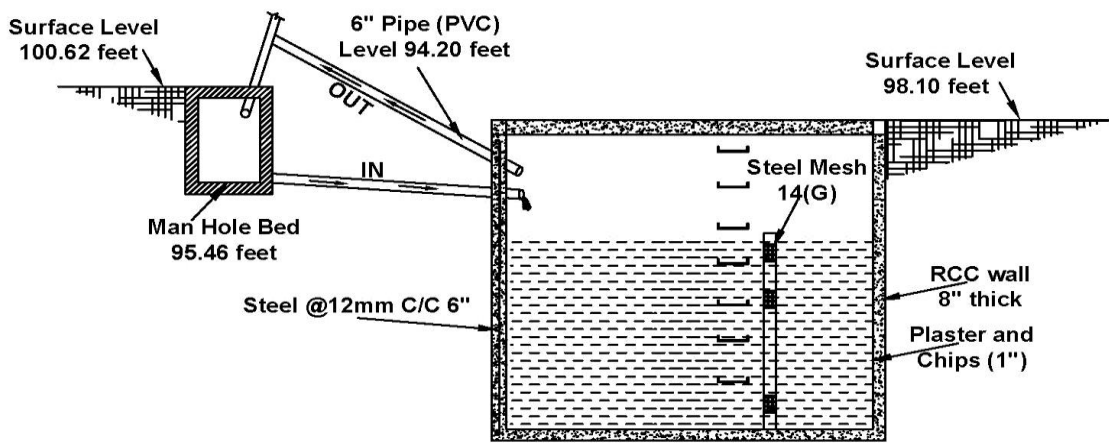

**SECTION (A-A) WETLAND TANK
(HYBRID) UNDER GROUND**

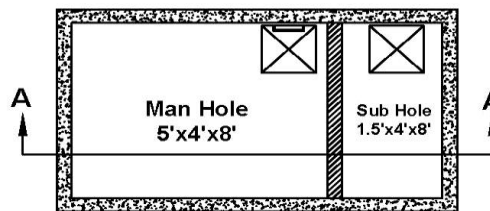

**PROPOSED WETLAND TANK
(HYBRID) UNDER GROUND**

PCRWR-SDO-2026

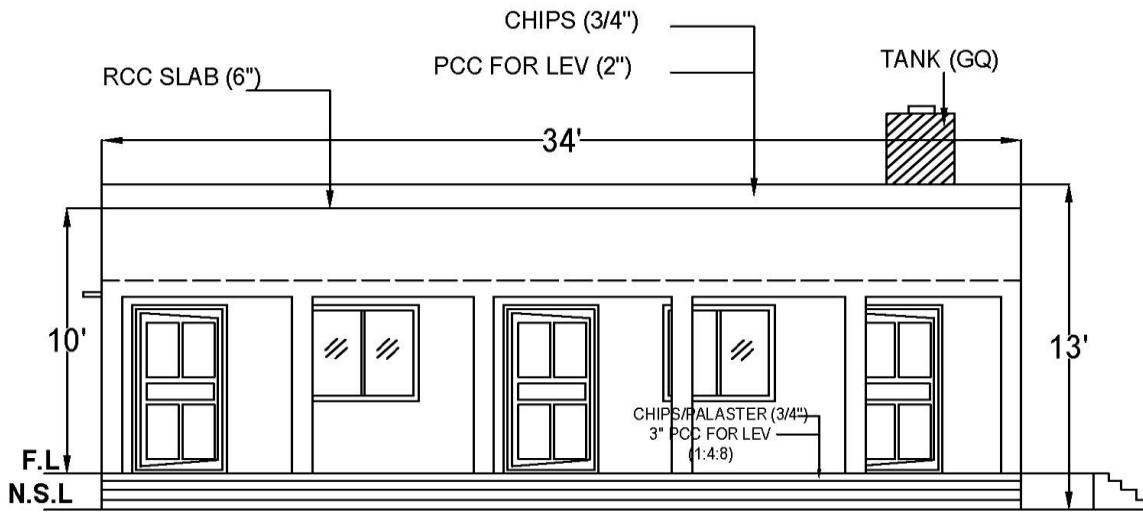

PROPOSED STRUCTURE/GF ELEVATION

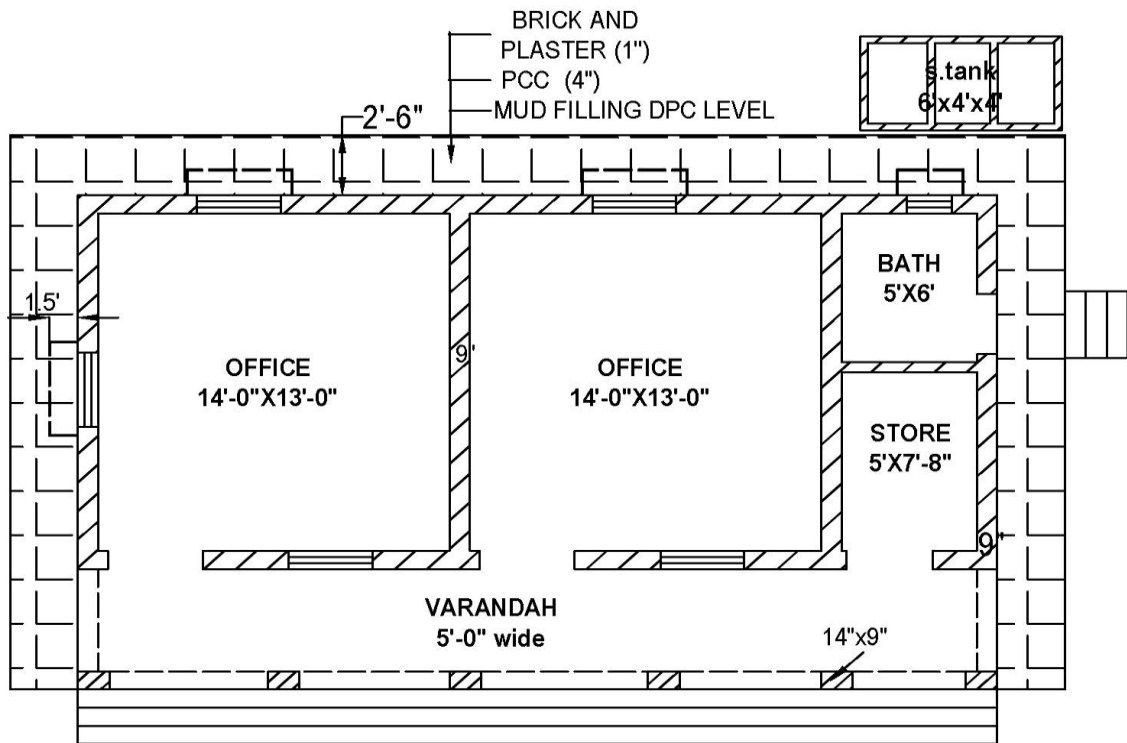

PROPOSED STRUCTURE/GF PLAN AT FARM GUJAR KHAN

PCRWR-SDO-2026

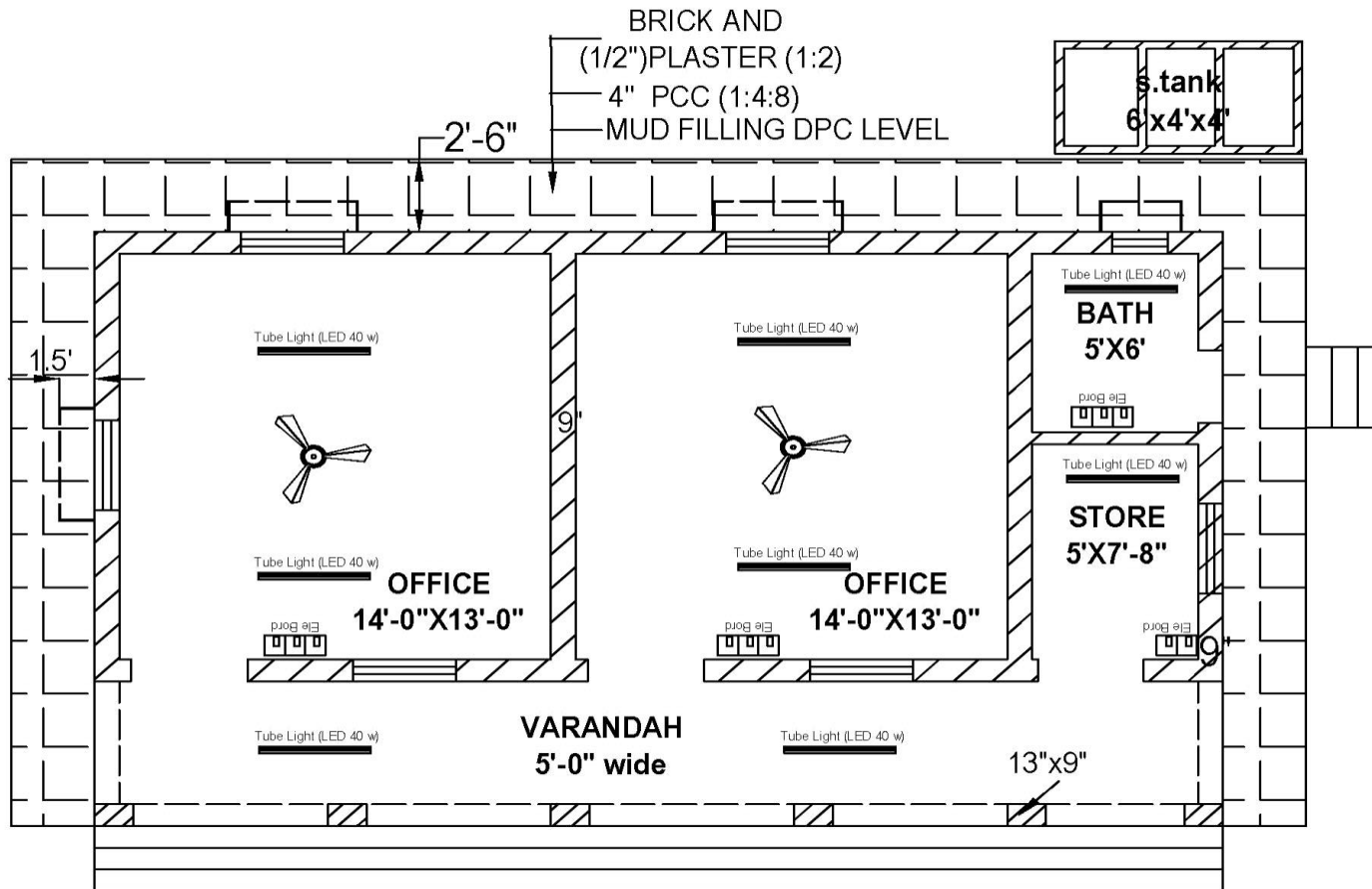

PROPOSED ELECTRICAL/GF PLAN AT FARM GUJAR KHAN

PCRWR-SDO-2026



WINDOW IRON GRILL VIEW

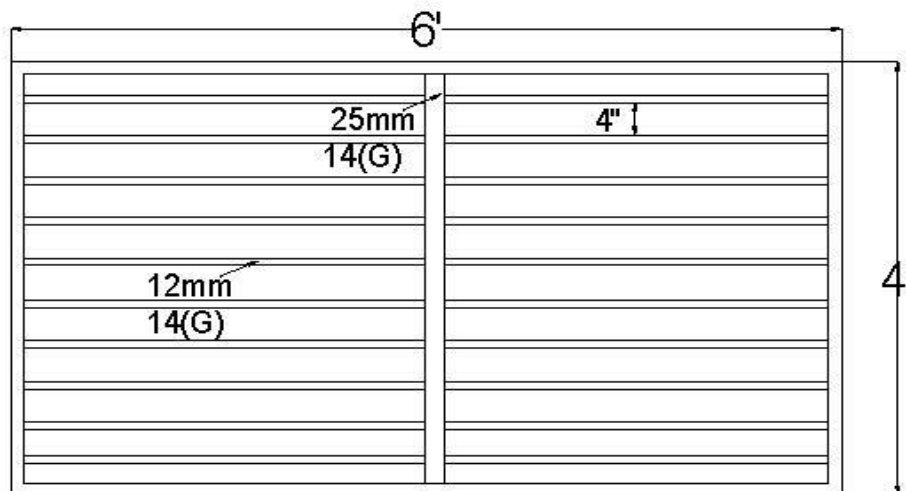

WINDOW IRON GRILL

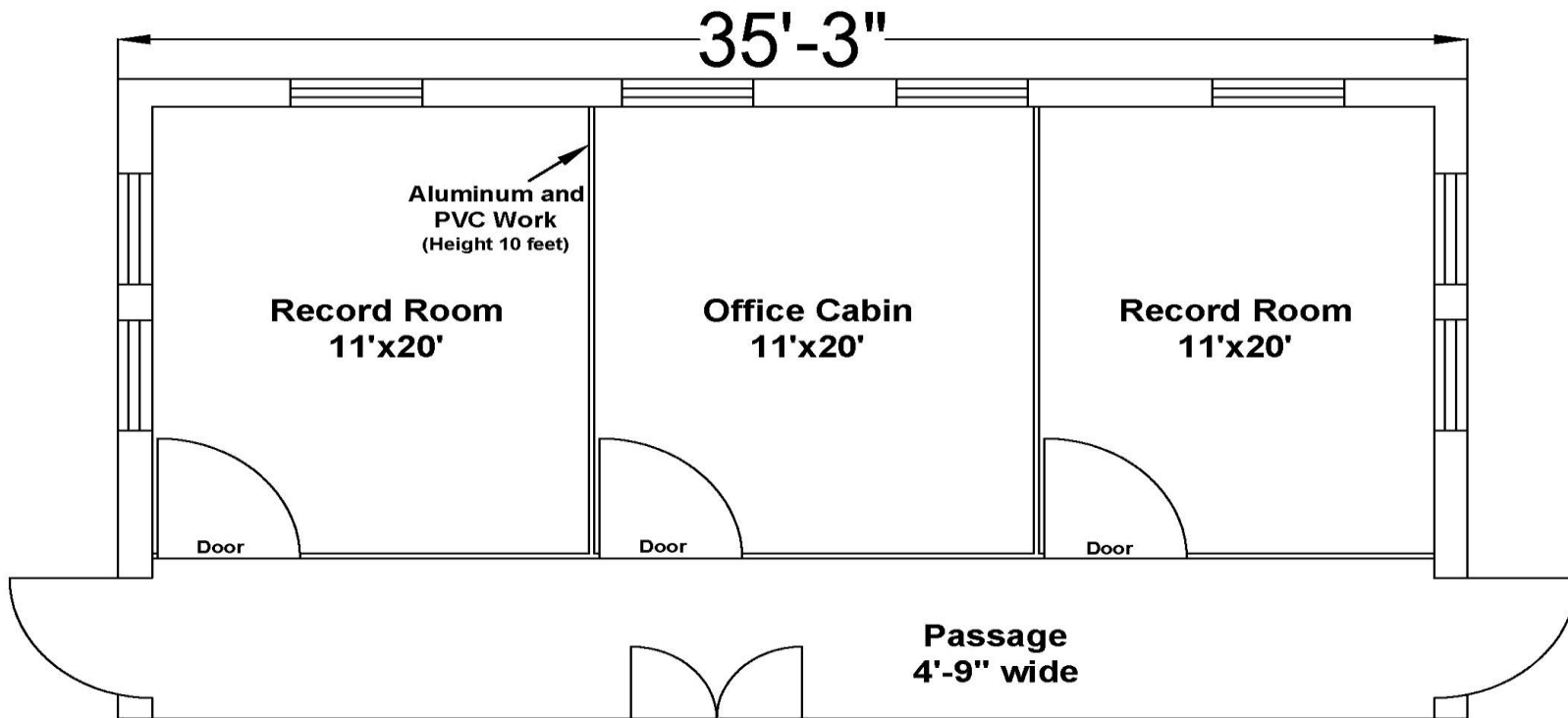

PROPOSED PLAN OF OFFICE AND RECORD ROOM

PCRWR-SDO-2026

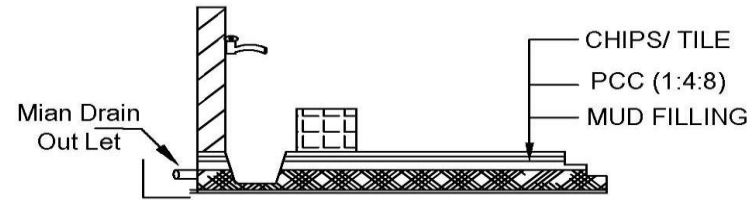

SECTION (A-A)

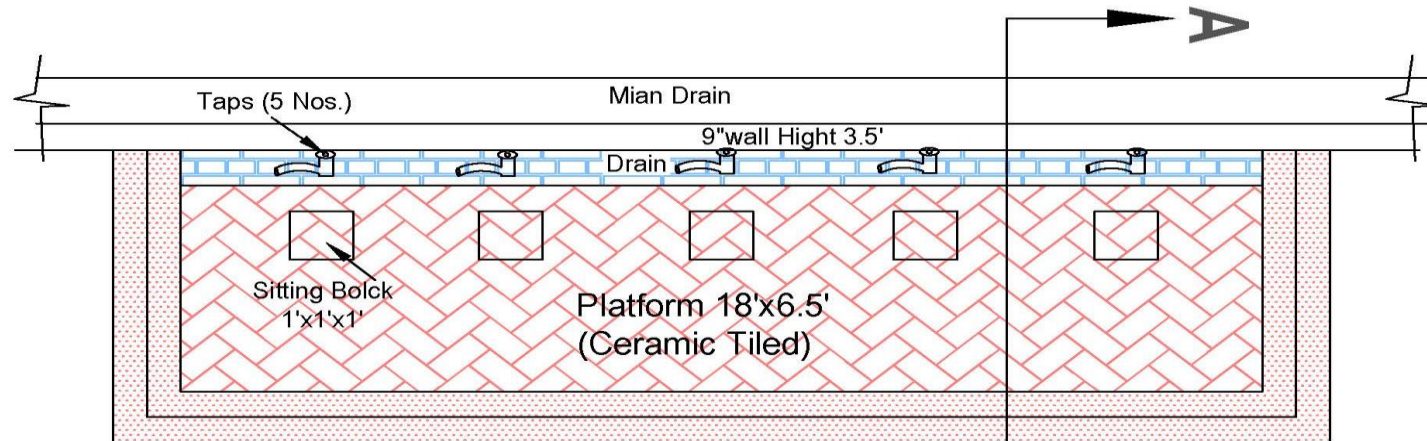

ABLUTION AREA PLAN

PCRWR-SDO-2026

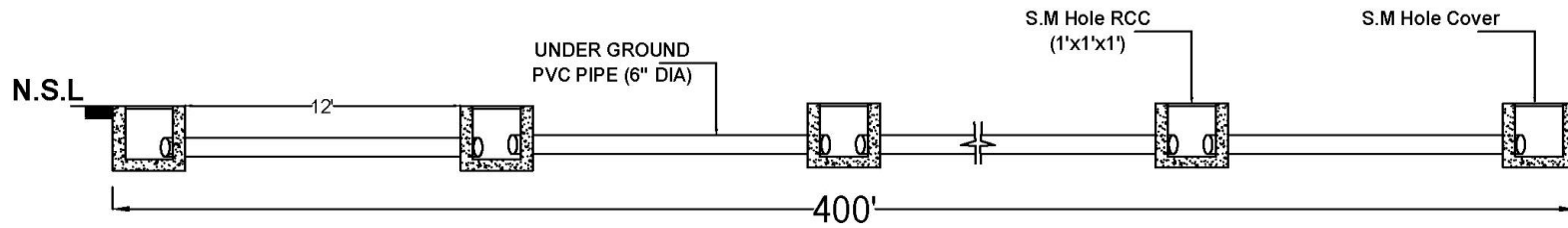

PROPOSED ELECTRICAL / TELEPHONE WIRES PIPE LINE

PCRWR-SDO-2026

SPECIAL STIPULATIONS

Conditions of Contract

1.	Law applicable	The law to be applied is the law of Islamic Republic of Pakistan
2.	Amount of Performance Security	Performance Security shall be provided in the following forms. <ul style="list-style-type: none">• 10% of Contract Price stated in Letter of Acceptance in shape of CDR issued by Scheduled Bank of Pakistan
3.	Time for Commencement	Within 10 days from the date of receipt of Engineer's Notice/Work Order.
4.	Time for Completion	<u>180 Days</u> from the date of commencement.
5.	Amount of Liquidated Damages	0.01 % for each day of delay in completion of the Works subject to a maximum of 10% of Contract Price stated in the Letter of Acceptance.
6.	Defects Liability Period	<u>364</u> Days from the effective date of Taking Over Certificate.
7.	Percentage of Retention Money	10 % of the amount of Interim Payment Certificate.
8.	Mobilization Advance (Interest Free)	10% of Contract Price in the form of cross cheque.

Certificate

(Must be provided on stamp paper)

1. That M/s _____ have read carefully the description of stores and all the terms and conditions of your tender due for opening on _____ for General Maintenance Works of PCRWR Building and Associated Infrastructure at PCRWR HQs Islamabad and R&D Farm Dar Kali Kalan. We agree to abide by all instructions and conditions as laid down in tender documents.
2. We understand that you are not bound to accept a lowest or any bid you may receive, not to justify for rejection of any bid and that you will not defray any expenses incurred by us in bidding.
3. We understand that Purchasing Agency is not bound to issue supply order of all items or any item keeping in view the budget available with it.
4. We undertake, if our proposal is accepted, to provide the Goods/Services mentioned in the contract within time frame specified, starting from the date of receipt of notification of award from the client Department / Office
5. It is declared that we are not suspended; black listed/defaulters of any Government/Autonomous Institution at any time.
6. In case of violation of any term and conditions, our security/call deposit may be forfeited which we shall not be challenged in any Court of Law.
7. We also hereby categorically confirm that the stores offered by us are exactly of the same particulars and specifications as laid down in your tender enquiry in all respects.
8. Certified that the prices quoted vide this Tender are not more than the prices charged from any other Purchasing Agency in the country or Prevailing Market Rates and in case of any discrepancy, the Tenderer hereby undertakes to refund the price charged in excess.
9. We accept that if the required bid security is not furnished or our offer is found lacking in any of the requirements of your tender document, tender shall be rejected.
10. We hereby confirm to adhere to the delivery period required in the Tender document which would be the essence of the contract and which will be strictly adhered to by us. It is certified that tenderer will be liable to supply items as per the specifications of the purchasing agency, if the same is found to be substandard and / or at variance with the specification given in the Tender Enquiry the security can be confiscated.

Name _____ Authorized Signature _____

Firm _____

(Authorized official Stamp) _____