



Sui Northern Gas Pipelines Limited (SNGPL)

“Design and Preparation of
Tender Document Including Site Investigations”

TENDER DOCUMENTS

For

COOLING TOWER AT COMPRESSOR STATION CC 1 HARANPUR

May – 2026



Head Office:

C-3, Jhelum Block, Green Fort-II, Lahore.
Phone: +92 42 35450914-15
Fax: +92 42 35450916,
Email: arslan@asiancon.com

Islamabad:

Office No. 21, 2nd Floor, 44-Zaki Centre,
I-8 Markaz, Islamabad.

Karachi:

Office No. 410, 4th floor, Business Avenue, PECHS,
Block-6, Main Shahrah-e-Faisal, Karachi.

Peshawar:

Syed's Tower, Office No. 1, 4th Floor, Opposit to
Custom House, University Road, Peshawar.





Quality Control Sheet



QUALITY CONTROL SHEET				
DOCUMENT	Tender Documents for Cooling Tower at Compressor Station CC 1 Haranpur			
PROJECT	"Design and Preparation of Tender Document Including Site Investigations"			
CODE	P22-185			
AUTHOR				
	19.05.2026			
VERIFIED				
	19.05.2026			
RECIPIENT	Sui Northern Gas Pipelines Limited (SNGPL)			
NOTES				

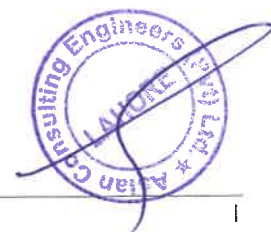



Table of Contents

Contractor HSE Statement.....	1
Form of Tender	8
Form of Agreement.....	11
Appendix – A	14
Special Conditions.....	17
Integrity Pact.....	23
General Terms & Conditions	26
Existing Site Conditions & Proposed Methodology	35
Specification to be Adopted and list of approved manufacturers/vendors	37
Approved Sample of Performance Bond/Guarantee	40
Special Clauses	43
Schedule of Payment	45
Bid Sheet.....	47
Bill of Quantities (BOQ).....	49





CONTRACTOR HSE STATEMENT

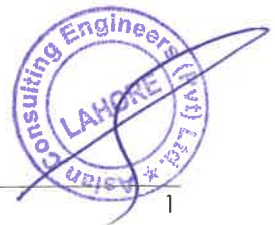



CONTRACTOR HSE STATEMENT



SUI NORTHERN GAS PIPELINES LIMITED

Doc. #SNGPL-GPR013-F001

Issue # 01

Issue Date

Contractor HSE Statement

Page 1 of 5

The Contractor shall prepare and maintain information including a clear method statement regarding Contract/Sub-Contract activities, which outline the work to be undertaken and the method (s) for minimizing and maintaining environmental impacts, OH&S Hazards and maintaining compliance with HSE regulation.

To assist in organizing and maintaining information, background information section has been included (section I, II, III) Section can be modified or deleted as required when requesting a method statement from Contractors/Sub-Contractors.

SNGPL's Personnel to Complete Section I, II, and III

Suppliers to Complete Section IV, V, and VI

Section I Your Information: (type or print)

Name	
Phone Number	
Fax Number	
Dept Name	

Section II Requisition Information:

Requisition Number	
Project Number: (If applicable)	

Section III Service or Activity to be Performed:

Material/Chemical: (Production/Non-production)	Paint Solvent Sealer	Treatment Chemicals Lubricants, Oils, Greases Gasoline	Janitorial Material Other (specify) _____ Other (specify) _____
Facilities/ Construction:	Ditching Electrical Paint Structural	Roofing Mechanical HVAC	General Contractor Arch/Engr/Consulting Other (specify) _____
Services: (Includes Environmental Services)	Janitorial Security Maintenance	Emergency Response Env. Consulting Paint Booth Cleaning	Waste Management Other (specify) _____
Containerization:	5 gal. or less Drums Bulk Tanks	Type of Contract	Commodity Management On-site Manager Provided Total Cost Contract





SUI NORTHERN GAS PIPELINES LIMITED

Doc. #SNGPL-GPR013-F001

Issue # 01

Issue Date

Contractor HSE Statement

Page 2 of 5

Section IV. Supplier/Contractor Information:

Current Supplier/Contractor to this Facility

New Supplier/Contractor to this Facility

Current Involved in other Facility Project(s)

List Project(s): _____

(Complete Information in table below):

(type or print)

Name:	
Address:	
City & Province:	
Phone Number:	
Fax Number:	
President/General Manager/CEO etc.	
Facility Site Coordinator:	
Email Address:	
Phone Number:	
Mobile Number:	
Fax Number:	
Pager:	
24 Hour Emergency Number:	





SUI NORTHERN GAS PIPELINES LIMITED

Doc. #SNGPL-GPR013-F001

Issue # 01

Issue Date

Contractor HSE Statement

Page 3 of 5

Sub-Contractor Information: (List supplier/Contractor not identified) (type or print)

Type	Firm Name
Architectural	
Mechanical	
Electrical	
Heavy Vehicles	
Industrial Services	
Painting	
Roofing	
Architectural/Engineering /Consulting Firm	
Sampling/Testing	
Chemical Supplier	
Other (specify)	
Scrap	
Waste Disposal	
Demolition Disposal	

Note: it is strongly recommended that you have your sub-contractor and suppliers involved at this facility should complete a separate HSE briefing package for the facility's review.





SUI NORTHERN GAS PIPELINES LIMITED

Doc. #SNGPL-GPR013-F001

Issue # 01

Issue Date

Contractor HSE Statement

Page 4 of 5

Section V. Contractor Method Statement:

Supplier/Contractor is financially responsible for on-site HSE remediation actions resulting from incidents involving their employees and sub-contractors. To minimize the risk of environmental accidents, please review and initial the items contained in the HSE Management Basics Table below.

Health, Safety and Environment Management Basics		Tick ()
1	Contractor will ensure that the <ul style="list-style-type: none"> Health of its employees is protected. All activities carried out for the execution of the job are safe. Compliance is met with all relevant laws and regulations. All HSE (Health, Safety and environment) procedure of the Company are implemented. Safe working environment is provided to its employees. 	
2	Contractor will take all necessary steps to minimize the hazards associated with the job. Appropriate personal protective equipment should be provided to the employees where hazards exist.	
3	All incidents resulting in Dangerous Occurrence minor or major injury fire vehicle accidents and environmental incidents are to be reported to Company with 24 hours.	
4	The Contractor is to make his own arrangements for treating injuries to his employees. In the event, Contractor's employee is injured while working for the Company. It is the Contractor's responsibility to notify the company representative immediately and to report the circumstances of injury.	
5	Contractor's mobile equipment such as trucks crane welding machines, etc must be maintained in good working conditioned. Contractor's trucks and other mobile equipment should be operated in such a way that material they are carrying does not fall off the equipment on to the roads. If repairs are required or vehicles become immobilized arrangement must be made to correct the situation with additional outside help.	
6	Prior to the start of work a certificate from a competent authority is to be given to the site in charge by the Contractor stating that all mobile heavy equipment are in good working conditioned. Only licensed and designated qualified people shall operate contractor's equipment.	

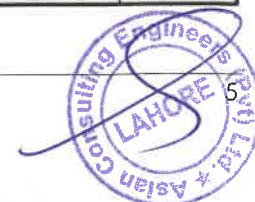



Health, Safety and Environment Management Basics		Tick ()
7	Company equipment must not be handled or tampered with by Contractor. The Company representative may grant permission to the Contractor on specific conditions to operate Company equipment if emergency conditions so require.	
8	When doing work involving excavation Contractors must not be damaged or break into or otherwise open any underground piping. Extreme care must be exercised in this respect while excavating with power driven equipment. If lines are accidentally damaged notify the company representative immediately.	
9	All excavation made by Contractors must be fenced barricaded or otherwise protected so as to prevent personnel from slipping or falling into them.	
10	Drawing/Excavation include safety talk notified for facilitating contract employees ever during transportation by Cos TPT.	
11	The authorized Company executive will issue a permit appropriate for any work to be done by the Contractor at Company designed sites where work permit procedure is applicable. After receiving permit for work the Contractor shall be guided by Company rules and applicable laws in performing his work.	
12	Contractor shall provide to all their staff the relevant PPE's as specified by the Company against each job. Contractor staff will do compliance.	
13	Contractor's job sites must be kept reasonably clean and free of rubbish and debris which may create tripping or fire hazard. Upon completion the Contractor shall leave the area in a clean and orderly manner, removing all Contractor's debris, equipment and excess material.	
14	Contractor shall dispose of all the waste generated from its activity in environment friendly manner as described in Pakistan Environment Protection Act, 1997.	





SUI NORTHERN GAS PIPELINES LIMITED

Doc. #SNGPL-GPR013-F001

Issue # 01

Issue Date

Contractor HSE Statement

Page 5 of 5

Section VI. Supplier/Contractor Certification: (review and sign)

I have reviewed and understand the information contained in this document. I also understand that SNGPL's HSE Personnel have the right to inspect our activities and those of our Suppliers/Contractors with regards to our on-site activities. I further understand that activities pertaining to service and/or maintenance contracts may only require submission of this form on an annual basis.

Name	
Title	
Signature	
Date	





FORM OF TENDER





FORM OF TENDER

Notes: - (The Appendix forms part of the Tender. Tenderers are required to fill up all the blank spaces in this, Tender Form and carefully review the Appendix).

To,
The Managing Director,
Sui Northern Gas Pipelines Ltd,
Sui Gas House, 21-Kashmir Road, Lahore.

Dear Sir,

Having examined the Drawings, Conditions of Contract, Specific Specifications, for the execution of the above-named works, we, the undersigned, offer to construct, complete and maintain the whole of the said works in conformity with the said Drawings, Conditions of Contract, Specific Specifications and Bid sheet for the sum of Rs. _____ (Rupees _____) or such other sums as may be ascertained in accordance with the said conditions.

2. I/We undertake if my/our Tender is accepted to commence the works within fifteen (15) days of receipt of the Company's (SNGPL) order to commence, and to complete and deliver the whole of the works comprised in the contract within the time mentioned in Appendix "A" calculated from the last date of commencement time.
3. If my/our tender is accepted, I/we will obtain the guarantee of Scheduled Bank/ approved Insurance Company (SNGPL) to be jointly and severally bound with us in a sum not exceeding ten (10%) percent of the above-named sum for the due performance of the Contract under the terms of Bond to be approved by you.
4. I/We agree to abide by this Tender for the period of One hundred and twenty (120) days from the date fixed for receiving the same and it shall remain binding upon us and may be accepted at any time before the expiration of that period.
5. Unless and until a formal Agreement is Prepared and executed, This Tender, together with your written acceptance thereof, shall constitute a binding Contract between us.
6. I/We understand that you are not bound to accept the lowest or any tender you may receive.
7. As a guarantee for the performance of the undertaking and obligations of this tender, we submit herewith Earnest money amounting to Rs. 270,000 in the form of original demand draft / pay order / deposit-at-call receipt in your favour and made payable to you, without any reference to us, and valid for





one hundred and twenty days (120) from the date set for opening of Tender.

Dated: _____ day of _____, 2025

Signature _____ in the capacity of _____

Authorized to sign tenders for & on behalf of _____
(IN CAPITAL LETTERS)

WITNESS:-

Signature: _____

Name: _____

Permanent Address: _____

Occupation: _____

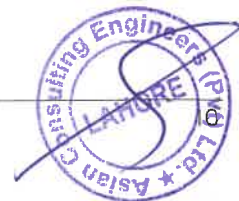



FORM OF AGREEMENT

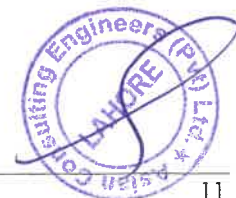



FORM OF AGREEMENT

This AGREEMENT made on _____ day of _____ 2025
between _____
_____ (hereinafter called "The
Employer") of the one part and _____
(hereinafter called "The Contractor") of the other part.

Whereas the Employer is desirous that certain Works should be constructed
viz. _____ and has accepted a
Tender by the Contractor for the construction completion and maintenance of such
Works.

NOW THIS AGREEMENT WITNESSED as follows:

1. in this Agreement words and expressions shall have the same meaning as are respectively assigned to them in the Condition of Contract herein after referred to.
2. the following documents shall be deemed to form and be read and construed as part of this Agreement viz:
 - a) the said Agreement and Tender Documents
 - b) the Drawings and further drawings
 - c) the Specific Specification
 - d) the Bid Sheet and mode of Payment
 - e) the Letter of Acceptance
 - f) the correspondence and instructions issued from time to time during execution of works.
3. in construction of the payment to be made by the Employer to the Contractor as herein after mentioned the Contractor hereby covenants with Employer to execute complete and maintain the works in conformity in all respects with the provisions of the contract.
4. the employer hereby covenants to pay the Contractor in consideration of the construction completion and maintenance of the Works at the contract price at the times and in the manner prescribed by the Contract.



5. Witness whereof the parties hereto have caused their respective Common Seals to be hereunto affixed (or hereunto set their respective hands and seals) the days and years first above written

Signed By

Managing Director
Sui Northern Gas Pipelines Ltd.
21 Kashmir Road Lahore

Contractor

Signature with Seal

IN THE PRESENCE OF

Name _____
Signature _____
Designation _____

Name _____
Signature _____
Designation _____

WITNESS

Signature _____
Name _____
Occupation _____
Address _____

Signature _____
Name _____
Occupation _____
Address _____

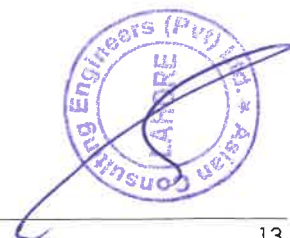



APPENDIX – A





APPENDIX – A

1	Earnest Money/Bid Security	Rs. 270,000/- Rupees (Must be submitted at the office of incharge (Civil), Civil Construction Department, 2nd Floor, Gas House 21 Kashmir Road Lahore in hard form along with Hard Copy of Tender Documents Signed & Stamped by the Contractor before Tender Submission Time otherwise the non-responsive). <i>Technical Bid must contain Earnest Money.</i>
2	Amount of Performance Bond or Guarantee	Ten Percent (10%) of the amount mentioned in the acceptance letter/work order (accepted amount) to be submitted within 15 days of issuance of work order issued by SNGPL approved Insurance Company
3	Validity of Performance Bond or Guarantee	Till satisfactory completion of Maintenance Period.
4	Validity Period of Bid	120 days from the date of opening of Tender
5	Time for Completion	Nine (09) Months for whole of the project including Mobilization Period of 15 days
6	Amount of Liquidated Damages	0.2% of the accepted amount/final cost of project per day for each day of delay
7	Limit of Liquidated Damages	10% of the total accepted amount or final cost of the project
8	Period of Maintenance	Eighteen (18) Months after issuance of completion certificate
9	Percentage of Retention Money	Ten percent (10%) of gross amount of each running bill
10	Limit of Retention Money	Five percent (05%) of FPC Amount
11	Payment of Retention Money	After successful completion of maintenance period and/or satisfactory rectification of all defects/deficiencies pointed out during maintenance period
12	Time within which payment to be made after Certification	<i>Sixty</i> Forty-five (45) <i>100</i> working days of SNGPL Head Office
13	Mode of Payment	The Partial payments (PPC`s) shall be processed on submission of claims by the contractor on completion of any work order activity (s) as per Mode of Payment/ Payment Schedule



14	Tender Documents Fee	Rs. 2500/- against Pay order in the Favour of M/s. Sui Northern Gas Pipelines Limited (Non-refundable) Must be submitted at the office of incharge (Civil), Civil Construction Department, 2 nd Floor, Gas House 21 Kashmir Road Lahore before tender submission date and time. Without Submission of Tender Fee, Bid would be declared non-responsive.
----	----------------------	---





SPECIAL CONDITIONS





SNGPL desires construction of the following works thru competent Civil Contractor to carry out the complete Civil & MEP construction works as per BOQ, Specifications and Drawings given in the Tender Documents.

Cooling Tower at Compressor Station CC1 Haranpur



- proof (work order & completion certificate). The same will be vetted by the Consultant before opening of the Financial Bids.**
- viii. **Complete data of the Contractor regarding projects of civil works (structure/Building/Rehabilitation/strengthening Works, at least 01) each of worth not less than five (05) million in hand with proof (work order & Agreement). The same will be vetted by the Consultant before opening of the Financial Bids.**
- ix. **Proof of personnel & equipment capabilities and financial soundness (available bank credit line and working capital in last three years).**
5. The 'Financial Proposal' should contain the tender documents with each page signed along with duly filled in 'Bid Sheet'.
6. After the submission of bid, no amendments shall be permitted.
7. The 'Technical Proposals' shall be evaluated after opening and the 'Financial Proposal' of bids found technically nonresponsive shall be returned un-opened to the respective bidders. Thereafter the 'Financial Proposals', of the technically accepted bids only, will be opened in the presence of concerned bidders.
8. In case of any conflict between the Design Drawings and the Technical Specifications, the Drawings shall supersede the Specifications.
9. If excess in the quantities of any item of work is required either due to requirement of the client departments of SNGPL or due to some other unavoidable site conditions, the same should be informed by the Contractor well in time in order to seek formal written approval from the INCHARGE (CIVIL). The Contractor should also quantify and inform the increase in cost of work due to any such excess in quantity of any item. Upon receipt of above stated intimation of the Contractor, the Company will issue formal written permission to the Contractor for proceeding ahead in the matter accordingly.
- The Contractor has no authorization to exceed the quantities of different items given in the work order without prior written permission of the INCHARGE (CIVIL). If any Contractor executes the construction work in such a way that causes excess in quantities of any item of work, over and above the work order quantities without prior written permission of the INCHARGE (CIVIL), the Company may refuse for payment against such excess quantities.
10. If the construction site is not cleared and handed over to the Contractor by the Company within 60 days of issuance of work order, the Contractor may withdraw his offer and in such case the Earnest Money and/or Performance Bond submitted by the Contractor will be returned by the Company.
11. Complete HSE (Health Safety and Environment) Contractor Manual is available at SNGPL website www.sngpl.com.pk which must be studied for true implementation during execution of work. Implementation of HSE procedures shall be ensured as per prevailing HSE policy of SNGPL during execution of works.



12. The Contractor must ensure the HSE Management Plan (safe system of works) at site to avoid any untoward incident including but not limited to following:
- i. Detail plan of activities to be carried out from start to execution/commissioning of subject project for example scaffolding, load lifting, work at height, use of mechanical equipment (moveable and immovable) etc. Detail JSA/Risk Assessment of the associated HSE hazards of each activity along with control measures.
 - ii. Detail of certified machinery along with trained/experienced operators. Certificate of operators will be required.
 - iii. Mechanism of effective HSE supervision of the project with dedicated HSE Engineers/Officers and staff.
 - iv. Firefighting plan with detail of firefighting staff capabilities and equipment.
 - v. First aid plan with detail of first aiders staff capabilities and equipment.
 - vi. Mechanism of manual and mechanical loading/unloading.
 - vii. Detail of accident/incident statistics of the contracted company.
 - viii. Detail of barricades, i.e., caution boards, hard barricades, barricading tape etc.
 - ix. Detail of PPE's.
 - x. Emergency Response Plan.
 - xi. Training and safety talks mechanism.
13. The Contractor shall be liable to pay compensation to his staff / labour in case of any major injury, disability and fatality category wise as under:

a.	In case of major injury (Injury leading to temporary disablement)	Payment of ½ of the monthly wages till the recovery of temporary disablement or for a maximum period of one year, whichever is less. Payment of 1/3 of the monthly wages till the recovery of chronic ill health / disease or for a maximum period of 5 year, whichever is less.
b.	In case of Disability (Permanent)	Rs. 500,000/-
c.	Fatality	Rs. 500,000/-

14. Failure to compliance against HSE initiative at operational sites will lead to blacklisting of a Contractor through following disciplinary action.

e.	1 st Violation	Warning-letter
f.	2 nd Violation	Deduction of Rs. 100,000/-
g.	3 rd Violation	Deduction of Rs. 500,000/-
h.	4 th Violation	Suspension for period of Six Months
i.	5 th Violation	Blacklisting



15. To ensure that Contractor obtains 3rd party insurance to cover such incident (Harmful Incidents / Any Accident)
16. To ensure the sufficient security is retained by the company from the Contractors to cover such case (Harmful Incidents / Any Accident)
17. Protective gear should be provided to workers by the Contractors to avoid such accidents (Harmful Incidents / Any Accident)
18. To take care of the above point in future as well as running contracts.
19. Minimum level of age/experience/skill of contractor's staff/labour should be checked by first line executives and HSE engineer against the relevant job. A clause should be included in the Contract awarding documents against this requirement.
20. Contractor's staff should use only those tools at site which have prior verification from first line executives and HSE engineer. A clause should be included in contract awarding documents against this requirement.





INTEGRITY PACT





INTEGRITY PACT

DECLARATION OF FEES, COMMISSION AND BROKERAGE ETC PAYABLE BY THE CONSULTANT/CONTRACTOR FOR SERVICES & WORKS IN CONTRACTS WORTH RS.10.00 MILLION OR MORE

Contract Number: _____

Dated: _____

Contract Value: _____

Contract Title: _____

[name of Consultant/Contractor] hereby declares that it has not obtained or induced the procurement of any contract, right, interest, privilege or other obligation or benefit from Government of Pakistan or any administrative subdivision or agency thereof or any other entity owned or controlled by it (GoP) through any corrupt business practice.

Without limiting the generality of the foregoing [name of Consultant/Contractor] represents and warrants that it has fully declared the brokerage, commission, fees etc. paid or payable to anyone and not given or agreed to give and shall not give or agree to give to anyone within or outside Pakistan either directly or indirectly through any natural or juridical person, including its affiliate, agent, associate, broker, consultant, director, promoter, shareholder, sponsor or subsidiary, any commission, gratification, bribe, finder's fee or kickback, whether described as consultation fee or otherwise, with the object of obtaining or inducing the procurement of a contract, right, interest, privilege or other obligation or benefit in whatsoever form from GoP, except that which has been expressly declared pursuant hereto.

[name of Consultant/ Contractor] certifies that it has made and will make full disclosure of all agreements and arrangements with all persons in respect of or related to the transaction with GoP and has not taken action or will not take any action to circumvent the above declaration, representation or warranty.

[name of Consultant/ Contractor] accepts full responsibility and strict liability for making any false declaration, not making full disclosure, misrepresenting facts or taking any action likely to defeat the purpose of this declaration representation and warranty. It agrees, that any contract, right, interest, privilege or other obligation or benefit obtained or procured as aforesaid shall, without prejudice to any other right and remedies available to GoP under any law, contract or other instrument, be void able at the option of GoP.

Notwithstanding any rights and remedies exercised by GoP in this regard, [name of Consultant/ Contractor] agrees to indemnify GoP for any loss of damage incurred by it on account of its corrupt business practices and further pay compensation to GoP in an amount equivalent to ten time the sum of any commission gratification, bribe, finder's fee or kickback given by [name of Consultant] as



aforesaid for the purpose of obtaining or inducing the procurement of any contract, right, interest privilege or other obligation or benefit in whatsoever form from GoP.

[Client]

[Consultant / Contractor]

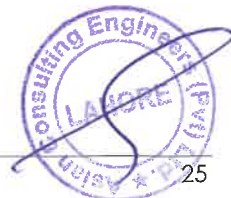



GENERAL TERMS & CONDITIONS

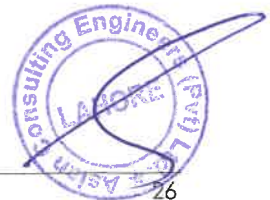



GENERAL TERMS & CONDITIONS

1. SITE CONDITIONS, CLEARING AND GRUBBING

The tenderers shall fully acquaint themselves with the site, site conditions, affecting in any way the cost of tender etc., before tendering. The work is to be completed in all respects, fully functional. The work also includes all necessary arrangements required to be made at site according to site requirements.

2. TENDER PREPARATION AND SUBMISSION

The tenders shall be prepared at tenderer's own cost and shall be submitted on prescribed form of tender in sealed envelopes on which only the name of work should be clearly written in capital letters while name of tenderer should not be written. All entries should be made in ink in both words and figures. All pages of the tender documents must be signed and stamped by the tenderer. The preparation of tender documents and any correspondence in connection with the tender documents should be in the English language. The tender should be delivered in person or by mail to the following address:

INCHARGE (CIVIL)
2ND FLOOR, S.N.G.P.L. HEAD OFFICE,
21-KASHMIR ROAD, LAHORE

so as to reach on or before the time and date given in Tender Invitation Notice/Letter, at which time and place, they will be opened. Tenderers are invited to be present at the opening of the tenders. Only the tenderer's name and total tendered prices will be announced. The tender documents thus once submitted shall become property of the Company and shall not be returned whatsoever.

3. CLARIFICATIONS, INTERPRETATIONS

The tenderer shall study the drawings and specifications carefully. Any information, clarifications, interpretations sought by the intending tenderers must be referred in writing to SNGPL will issue necessary instructions in writing to all tenderers simultaneously, which will become part of the contract. The tenderers shall sign copies of all such addenda and submit them together with the tender documents and drawings. Verbal discussions shall not to be considered binding. No extension in the closing date shall be demanded on account of any such clarification and/or interpretation having received late. If no clarification is obtained within the prescribed time and later on any discrepancy (e.g., mismatch between any tender documents etc.,) is noticed, then the decision of the Company shall be final and binding.





4. MODIFICATIONS

Modifications in the tender documents, if required by the Company, will be made by issuing addenda to the Tender Documents. Intimation of such modifications will be sent to each tenderer, minimum four days prior to the date of submission of tenders. No amendment or modification of the contract shall be made except in writing and signed by the Company.

5. CONDITIONAL TENDER

Conditional tender will not be accepted.

6. RATES

The Contractors shall quote the rate on lump sum cost basis (if not given otherwise) in the bid sheet attached to construct, complete and maintain the works included in the bid sheet, to the fully functional/operational conditions covering and including all the civil works, public health and sanitation work, electrical works, laying conduit pipe for telephone lines, external works and all other services whether or not shown in the drawings or given in the specific specifications. For this purpose, Contractors shall calculate and evaluate the quantities and quantum of works themselves and no claim of Contractors whatsoever shall be entertained by the Company for any mis-calculation of tender by the Contractors. The rates quoted by the Contractors shall be for complete finished work and shall be comprehensive and complete in all respects including cost of all materials, labour, tools and plants, carriage, taxes, profits, incidental charges etc.

7. RATE ANALYSIS

The Contractors should provide rate analysis of each item (if required).

8. RIGHT OF REJECTING TENDER

The Company shall have the right of rejecting any or all of the tenders. The Company is not bound to award the contract to the lowest tenderer.

9. EARNEST MONEY

A Demand Draft, Pay Order, Deposit-at-Call or Deposit Receipt issued from any scheduled bank of Pakistan (preferably at Lahore), equal to Rs. 270,000/- amount of work in favour of Sui Northern Gas Pipelines Limited, Lahore shall be submitted before tender opening date as earnest money on the addressed mentioned at Appendix-A. Tenders without Earnest Money will not be entertained. Cheques and cash will not be accepted. The earnest money of unsuccessful tenderers shall be returned

- a. After execution of contract agreement with the successful tenderer or
- b. If all the tenderers are rejected, after such rejection or
- c. Within sixty days of opening of tender



The earnest money of the successful tenderer shall be returned after submission of Performance Bond. If the tenderer to whom the contract is awarded refuses or neglects to execute the agreement than the earnest money will be forfeited and contract may be rescinded. If the construction site is not cleared and handed over to the Contractors by the company within 60 days of issuance of work order, the earnest money will be returned to the Contractors by the company.

10. VALIDITY OF BID

The bid shall remain valid and may remain open and binding for a period of 120 days from the date of opening of tender or until the work order issued to the successful tender.

11. PERFORMANCE BOND OR GUARANTEE

The Contractors will have to submit, at his own expense, Performance Bond as per detail given in Appendix-A. Terms of the bond shall be as per sample provided by the Company.

12. STANDARD OF WORK

The work shall be done to the entire satisfaction of the Company. The Company is the sole judge to approve the standard of work and if any defects are observed upto completion of maintenance period, the Contractors shall make good all such defects at his own risk and cost including materials. If the Contractors fails to do any such work, as aforesaid required by the Company, the Company can get the same work done through any other means and all expenses consequent thereon or incidental thereto shall be recoverable from the Contractors by the Company or may be deducted by the Company from any money due or which may become due to the Contractors.

13. HSE POLICY

SNGPL is committed to the health and safety of its employees, preservation of environment and continual improvement of HSE performance by reducing potential hazards, preventing pollution and adhering to applicable laws and regulations in all its activities related to its Contractors. Following should be ensured by the Contractors.

1. Usage of Personal Protective Equipment.

The use of personal Protective equipment is to reduce employee's exposure to hazard when engineering and administrative controls are not feasible or effective to reduce the risks to acceptable levels. Personal Protective Equipment is last line of defence.

2. Wearing of closed shoes.
3. Not wearing loose clothes.
4. Not to use defective machinery and plant.



5. Not to work in unsafe condition.
6. Not to perform unsafe acts.

14. REMOVAL OF ANY CONTRACTOR'S EMPLOYEE FROM SITE

The Company shall be at liberty to object to and require the Contractors to remove forthwith from the works any person employed by the Contractors in or about the execution or maintenance of the works, who, in the opinion of the Company, misconducts, or is incompetent or negligent in the proper performance of his duties, or whose employment is otherwise considered by the Company to be undesirable and such person shall not be again employed upon the works without the written permission of the Company. Any person so removed from the works shall be replaced as soon as possible by a competent substitute approved by the Company.

15. CONTRACTORS LIABLE FOR DAMAGE TO PLANT AND PEOPLE ETC.

The Contractors shall be at any time be liable for the loss of or damage to any of the said constructional plant, temporary works, materials and people including labour etc.

16. SERVICE OF NOTICES ON CONTRACTORS

All certificates, notices or written orders to be given by the Company to the Contractors under the terms of the contract shall be served by sending by post to or delivering the same to the Contractors principal place of business, or such other address as the Contractors shall nominate for this purpose.

17. SUBLETTING

No subletting of major work shall be done without prior written permission of the Company.

18. REMOVAL OF IMPROPER WORK AND MATERIAL

- a. The Company shall during the progress of the works have power to order in writing from time to time:
 - i. The removal from the site, within such time or times as may be specified in the order, of any materials which, in the opinion of the Company, are not in accordance with the contract.
 - ii. The substitution of improper and unsuitable materials and
 - iii. The removal and proper re-execution, notwithstanding any previous test thereof or interim payment therefore, of any work which in respect of materials or workmanship is not in the opinion of the Company, in accordance with the contract.
- b. Default of Contractor's Compliance

In case of default on the part of the Contractors in carrying out such order, the Company shall be entitled to employ and pay other persons to carry out the same and all expenses consequent thereon or incidental thereto shall be recoverable from the Contractors by the Company, or may be deducted by





the Company from any money due or to which may become due to the Contractors.

19. RATE OF PROGRESS

If for any reason, which does not entitle the Contractors to an extension of time, the rate of progress of the works or any section is at any time, in the opinion of the Company, too slow to ensure completion by the prescribed time, the Company shall so notify the Contractors in writing and Contractors shall thereupon take such steps as are necessary and the Company may approve to expedite progress so as to complete the works or such section by the prescribed time. The Contractors shall not be entitled to any additional payment for taking such steps. If as a result of any notice given by the Company under this clause, the Contractors shall seek the Company's permission to do any work at night or on Sunday, if locally recognized as days of rest, or their locally recognized equivalent, such permission shall not be unreasonably refused. If it is still felt that the progress of the Contractors is not satisfactory and in the opinion of the Company, the project is likely to be delayed due to poor progress, the remaining work can be taken over from the Contractors after giving notice of 14 days and the work can be got completed at the risk and cost of the Contractors.

20. ADVANCE PAYMENT

No advance payment shall be made except described in Appendix-A.

21. CORRECTION AND WITHHOLDING OF PAYMENT CERTIFICATES

If the works or part of the works contained in the PPCs/FPC of the Contractors are found incomplete, defective, rejected and/or with calculation error(s) etc., the Company shall and/or can:

- a. Correct and deduct from the bill such amount or amounts as the Company may consider proper and reasonable or
- b. Withhold payment certificate till the proper completion and rectification of the works or part(s) thereof, or
- c. Send back the said bill to the Contractors for resubmission of proper bill in proper form and details as required by the Company.

The Contractors shall have no claim whatsoever for any delay thus occurring in issuing the payment certificates and releasing the payment thereof.

23. INCOME TAX DEDUCTION

As required under the law, Income Tax will be deducted as per prevailing Government instructions and deposited with the Income Tax Department. However, a certificate for such deduction will be issued to the Contractors.

24. VARIATIONS

The Company shall make any variations of the form, quality or quantity of the works or any part thereof that may, in its opinion, be necessary and for that





purpose, or if for any other reason it shall, in its opinion be desirable, the Company shall have power to order the Contractors to do and the Contractors shall do any of the following:

- a. Increase or decrease the quantity of any work included in the contract.
- b. Omit any such work
- c. Change the character or quality or kind of any such work
- d. Change the levels, lines, position and dimensions of any part of the works, and
- e. Execute additional work (s) of any kind necessary for the completion of the works

And no such variation shall in any way vitiate or invalidate the contract. Additional proportionate time may be allowed by the Company on the basis of any addition in work (s) as per following:

1. If excess in the quantities of any item of work is required either due to requirement of the client departments of SNGPL or due to some other unavoidable site conditions, the same should be informed by the Contractors well in time in order to seek formal written approval from the ~~In-charge (Civil)~~ ^{HOD}. The Contractors should also quantify and inform the increase in cost of work (s) due to any such excess in quantity of any item.
2. Upon receipt of above stated intimation of the Contractors, undersigned will issue formal written permission to the Contractors for proceeding ahead in the matter accordingly.
3. The Contractors have no authorization to exceed the quantities of different items given in the work order without prior written permission of the ~~In-charge (Civil)~~ ^{Head of Department (HOD)}.
4. If any Contractors execute the construction work (s) in such a way that causes excess in quantities of any item of work, over and above the work order quantities without prior written permission of the ~~In-charge (Civil)~~ ^{HOD}, the Company may refuse for payment against such excess quantities.

25. VALUATION OF VARIATION

All extra or additional work (s) done or work (s) omitted by the order of the Company shall be valued at the rates and prices set out in the contract if, in opinion of the Company, the same are reasonable, otherwise the same will be rationalized as per following formula given for non-BOQ items.

The rates for additional works (non-BOQ), if any, will be calculated on the basis of following guidelines:

- i. Average market price of material specified quality.
- ii. Cost of labour worked out rationally.



- iii. 10% of cost of material and labour as overhead expenses and taxes of Contractors.
- iv. 15% of cost of material and labour as profit of the Contractors.

26. ESCALATION

No escalation in respect of any kind of material and labour shall be paid in any case due to increase of prices in the market.

27. NATIONAL TAX NUMBER AND PROFESSIONAL TAX CLEARANCE CERTIFICATE

The Contractors will have to produce National Tax Number and Professional Tax Clearance Certificate.

28. COMPLETION TIME

The Contractors shall complete all contract works within stipulated 'Time of Completion' as given in Appendix-A.

29. TIME EXTENSION

Delay in work due to special circumstances of any kind which may occur other than through default of the Contractors shall entitle the Contractors to an extension in time for completion of work. These special circumstances may include war, riots, epidemics, adverse climatic conditions, law and order situation or other circumstances of such kind which are beyond the reasonable control of the Contractors. The Company shall determine the amount of such time extension and shall notify to the Contractors accordingly.

30. LIQUIDATED DAMAGES (PENALTY)

In case of delay in completion of work from stipulated completion date on the part of the Contractors, Liquidated Damages (Penalty) for such default of the Contractors will be imposed as per the percentage amount given in the Appendix-A for each day of delay. This clause, however, shall not be applicable if in the opinion of the Company, the delay is due to war, riots, epidemics and/or any other reason out of reasonable control of the Contractors. The Company, may without prejudice to any other method of recovery, deduct the amount of such damages from any money in its hands, due or which may become due to the Contractors. The payment or deduction of such damages shall not relieve the Contractors from his obligation to complete the works, or from any other of his obligations and liabilities under the contract.

31. REMEDY ON CONTRACTOR FAILURE TO CARRY OUT WORK REQUIRED

If the Contractors shall fail to do any such work(s) as aforesaid required by the Company, the Company shall be entitled to employ and pay other persons to carry out the same and if such work is the work, which in the opinion of the Company, the Contractors were liable to do at his own expense under the



contract, then all expenses consequent thereon or incidental thereto shall be recoverable from the Contractors by the Company, or may be deducted by the Company from any money due or which may become due to the Contractors.

32. BLACKLISTING

If the Contractors fail to execute the work as per contract, the Company may delist his name from SNGPL and the same will be forwarded to PPRA and Pakistan Engineering Council and may blacklist his name for future participation in tender.

33. PROCESS OF PAYMENT/CORRESPONDENCE

1. Work will be completed by the contractor to whom job assigned.
2. PPCs/FPC will be processed on the name of firm's proprietor including name duly signed and stamped by the proprietor.
3. Cheques payment will be processed on the name of proprietor including firm's name.
4. No representative of the firm will sign the official documents on behalf of proprietor.
5. None of proprietor/ representative of firm allowed to do business with the company the of any other firm.





EXISTING SITE CONDITIONS & PROPOSED METHODOLOGY



EXISTING SITE CONDITIONS & PROPOSED METHODOLOGY/SCOPE OF WORKS

Cooling Tower at Compressor Station CC1 Haranpur

Note:

Any name of brands mentioned here are not binding, these are mentioned just for reference and easy understanding. However, any approved equivalent solution can be provided subject to assurance that alternative solution can provide equal and effective results.



SPECIFICATION TO BE ADOPTED AND LIST OF APPROVED MANUFACTURERS/VENDORS





**SPECIFICATIONS AND
LIST OF APPROVED MANUFACTURERS/VENDORS**

All equipment/material shall conform to relevant codes and specifications given in BOQ/drawings and shall be from approved sources indicated below. However, in every case the Contractor shall submit complete technical details of the equipment and material and obtain Engineer's approval prior to delivery on site duly vetted by the Consultant. Where Approved Equivalent is indicated, it shall be at the sole discretion of the Engineer to accept or reject the alternate proposal submitted by the Contractor. In the event "Approved Source" of any equipment / material is not indicated below the contractor shall obtain the approval of the Engineer prior to placing order on any supplier. During the execution stage if the material from any supplier is found defective/Sub-standard the Engineer reserves the right to ask the successful bidder to replace his choice of manufacturer / supplier for that particular equipment.

Sr. No.	Description/Materials	Brands/Vendors
1.	Crushed Stone Aggregate	Sargodha (black) or any approved equivalent
2.	OPC Cement	DG, Askari, Maple Leaf or any approved equivalent
3.	Reinforcement Steel, Deform, G-60 & 40	AFCO, Mughal, Fazal or any approved equivalent
4.	Sand	<ul style="list-style-type: none"> • Local Sand PCC 1:4:8, Brick Masonry, Sand Filling • Lawarancepur sand for plaster • 100% Lawarancepur for all RCC Works
5.	Construction Chemicals	<ul style="list-style-type: none"> • SIKA • Radiant Construction Technologies • Pak Chemicals • Approved Equivalent
6.	G.I. Pipes/Sheets	ILL (M)
7.	Hot Bitumen	PB3 or PB4
8.	Polythene Sheet	60 Sft = 1kg
9.	Double Tee Planked R.C.C Roof Slab	Izhar Group of companies

NOTE:

1. All materials shall be as per brands/specifications given in above table or equivalent approved by Incharge (Civil) and duly vetted by the Consultant.
2. Samples of all construction material should be got approved from the Incharge (Civil) before installation at site.
3. Original cash memo/certificate from authorized dealer will be provided by the Contractor to Incharge (Civil) before installation when required.
4. All PCC, RCC Cylinder strength and steel grade would be according to the provisions of BOQ and drawings. Same provisions will prevail for steel cover.





APPENDIX: LIST OF APPROVED INSURANCE COMPANIES

List of approved insurance companies for performance bond only

1. National Insurance Corporation
2. Habib Insurance Company Limited
3. Eastern Federal Insurance Co. Ltd
4. Premier Insurance Co. Ltd
5. New Jubilee Insurance Co. Ltd
6. Universal Insurance Co. Ltd
7. Adamjee Insurance Co. Ltd
8. National Security Insurance Co. Ltd
9. The Pakistan General Insurance Co. Ltd
10. United Insurance Co. Ltd
11. Atlas Insurance Co. Ltd
12. IGI Insurance Co. Ltd

Note: Performance or other guarantees from Insurance Company will be accepted as long as the Insurance Company is of category A+ or above, as per ratings issued by Pakistan Credit Rating Agency Limited (PACRA). Earnest Money and Mobilization Advance Guarantee will, however, be acceptable from Scheduled Banks of Pakistan.





APPROVED SAMPLE OF PERFORMANCE BOND/GUARANTEE





APPROVED SAMPLE OF PERFORMANCE BOND/GUARANTEE

No. : _____
Dated : _____
Amount : _____
Expiry date : _____

To
The Managing Director
Sui Northern Gas Pipelines Limited
Sui Gas House
21- Kashmir Road
Lahore

Dear Sir,

BY THIS BOND/ GUARANTEE _____

_____ Lahore whose registered office is at _____ hereinafter called the "SURETY" do hereby bind ourselves and our successors and assigns jointly and severally by these presents, to pay the Sui Northern Gas Pipelines Ltd., Lahore (hereinafter called the "COMPANY") unconditionally on demand and without further questions, the sum of Rs. _____ (Rupees _____) sealed with our seal and dated Lahore this _____ day of _____.

WHEREAS

M/s _____ (hereinafter called the "CONTRACTORSS") for submitting tender for _____

_____ a Work Order No. _____ dated _____ made between the "COMPANY" of the one part and the "CONTRACTORS" of the other part has entered in to a contract (hereinafter called "THE SAID CONTRACT") for the construction of aforesaid works as herein mentioned in conformity with the provisions of the said contract and the sum mentioned in the above written Bond/ Guarantee represents the retention money to be furnished by the Contractors for fulfillment of the said contract.

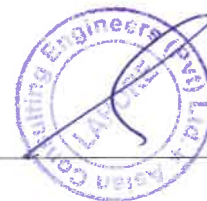



NOW THE CONDITION of the above written Bond/ Guarantee is such that if the Contractors shall duly perform and observe all the terms, provisions, conditions and stipulations of the said contract on the Contractors part to be performed and observed according to the true purport, intent and meaning thereof as determined by the company who shall be the sole judge in the matter or if on default by the Contractors for which the company shall be the sole judge, the surety shall satisfy and discharge the damages sustained by the company thereby and determined by the company of the above written bond/ Guarantee, then this obligation shall be null and void but no alteration in terms of the said contract made by agreement between the company and the Contractors or in the extent or the nature of the works to be constructed, completed and maintained there under and no allowance of the time by the company under the said contract nor any forbearance or forgiveness in or in respect of any matter or thing concerning the said contract on the part of the company shall in any way release the surety from any liability under the above written Bond/ Guarantee.

This Performance Bond/ Guarantee is valid up to _____ (including time of completion of work and completion of maintenance period).

Yours faithfully,

For and on behalf of "Surety"

SURETY NAME _____

Authorized Signature

Authorized Signature

The Common seal of the ("Surety") _____ is hereunto affixed in the presence of:

WITNESSES:

1.
Name: _____
CNIC No. _____
Signature: _____

2.
Name: _____
CNIC No. _____
Signature: _____





SPECIAL CLAUSES

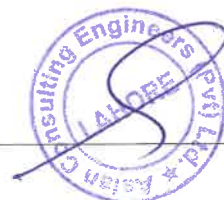



SPECIAL CLAUSES

SC1. TESTING OF CONSTRUCTION MATERIALS ETC:

Tests but not limited to the following for construction materials shall be carried out:

Sr. No.	Material	Test	Reference
1	Concrete	i Slump Test	ASTM C 143
		ii compressive test of 6" dia x 12" long cylinder at 28 days	ASTM C -39
2	Bricks	Compressive Strength 1800 psi	ASTM C 0067-03a
3	Aggregate	1. Sieve Analysis	ASTM C 136-5
		2. Crushing Strength by Los Angeles Abrasion Test	ASTM C 131-03
4	Reinforcement Steel	1. Tensile Strength	ASTM A 615/A
		2. Elongation Test	ASTM A 615/A

- i. The Contractor will pay all the expenses relating to material testing including but not limited to the cost of metrical sample preparation carriage and testing in lab etc.
- ii. The Contractor shall make available at site the equipment/apparatus required for testing of material as directed by the Company.
- iii. The quantity of sample and the frequency of tests will be as per above standard or as directed by the Company.

SC2. UTILITIES:

The Contractor shall provide where possible at site Contractors staff accommodations water supply and electric power free of cost.

SC3. QUANTITIES IN BID SHEET:

The quantities given in bid sheet are only for reference and payment shall be made as per actual measurement at site.

SC4. IMPLEMENTATION OF HSE PROCEDURES:

The successful bidder shall follow all the applicable HSE procedures and policies at construction site in accordance with Contractors HSE statement.

SC5. TESTING ARRANGEMENT/EXPENSES:

Testing arrangement/expenses for construction materials, concrete and compaction of road works from approved laboratories (approved by SNGPL representative/site Incharge) shall be responsibility of Contractor. All tests of construction materials and final product elaborated in Technical Specifications will be performed after which the works will be considered as approved for final payment.



SCHEDULE OF PAYMENT





MODE OF PAYMENT/PAYMENT SCHEDULE

Cooling Tower at Compressor Station CC1 Haranpur

Payment shall be made against each bill as per Bid Sheet/BOQ upon completion of respective Job associated with that specific bill strictly in accordance with the methodology/scope of works proposed in these tender documents.

NOTE:

1. These payments will be considered for approval/payment only after complete testing of the construction materials involved and other related tests specified in the tender documents, drawings and provisions of BOQ.
2. The quantities given in BOQ are only for reference however work to be carried out as per specification/drawings given in tender document and payment shall be processed as per the Mode of Payment.
3. ^{Minimum} PPC (Partial Payment Certificate) is 30% of Work Order Amount.



BID SHEET





BID SHEET

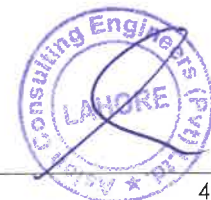



BILL OF QUANTITIES (BOQ)



**SUI NORTHERN GAS PIPELINES LIMITED
(SNGPL)**

**COOLING TOWER AT COMPRESSOR STATION
CC1 HARAPUR**

Bill of Quantity

General Abstract of Cost

Sr.No	Description	Amount Rs.
1	Civil Works	
	16% PST	
	GRAND TOTAL AMOUNT	



SUI NORTHERN GAS PIPELINES LIMITED (SNGPL)

**COOLING TOWER AT COMPRESSOR STATION
CC 1 HARAPUR**

BILL OF QUANTITY

Sr.Nr.	MRS Input Rates 2026 1st BiAnnual	Description	Unit	Qty	Unit Rate	Amount Rs.
1	2	3	4	5	6	7=6x5
		Bill Nr.1: Civil Works				
		Schedule Items				
1.1	3-21(a)(ii)	Excavation in foundation of building, bridges and other structures, including dagbelling, dressing, refilling around structure with excavated earth, watering and ramming lead upto one chain (30 m) and lift upto 5 ft. (1.5 m) 1). Depth upto 5ft (1.5m) b) By Excavator ii) Ordinary soil	Cu.m	234.08		
		a) Depth from 5.1 ft (1.5m) to 15 ft (4.5 m):- ii) Ordinary soil	Cu.m	138.89		
1.2	26-43	Spraying termite proofing by using liquid FMC/ Biflex/ Terminex Exin/ Ms Hextar or equivalent @ specified suspension concntrate rate (SC), Mixing Ability - HEXTAR with Ratio (1:250)= 540 Sq.m or equivalent approved liquid applying with shower and certificate will be provided by the contractor for 10-years complete in all respect. as approved by the Engineer Incharge.	Sq.m	624.20		
1.3	6-5	Cement concrete plain including placing, compacting, finishing and curing complete (including screening and washing of stone aggregate): (i) Ratio 1: 4: 8 (123 Km Lead)	Cu.m	15.61		
		Strength Based Concrete Providing and laying reinforced cement concrete (including prestressed concrete), using Ordinary Portland Cement / Sulphate resisting cement / Slag cement as may be required; coarse sand and screened graded and washed aggregate, in required shape and design, including forms, moulds, shuttering, lifting, compacting, curing, rendering and finishing exposed surface, complete (but excluding the cost of steel reinforcement, its fabrication and placing in position, etc):-				
1.4						
1.5	6/6(a)(iii)	(a) Reinforced cement concrete in roof slab, beams, columns lintel girders and other structural members laid in in situ, complete in all respects:- (123 Km Lead)				
	+1-1	(2) Type B (nominal mix 1: 1½: 3)	Cu.m	25.20		
		(b) Reinforced cement concrete in retaining/Shear walls laid in-site or precast laid in position,or prestressed members cast insitu Form work on both sides) , complete in all respects: (2) Type B (nominal mix 1:1-1/2:3) (ii) More Than 9" thick (Avg)	Cu.m	112.07		
	6/6(c)(i)	(c) Reinforced cement concrete in Pile cap, slab of rafts / strip foundation, base slab of column and retaining walls; etc and footing beams, other structural members other than those mentioned in 6(a-d)				



SUI NORTHERN GAS PIPELINES LIMITED (SNGPL)

**COOLING TOWER AT COMPRESSOR STATION
CC1 HARAPUR**

BILL OF QUANTITY

Sr.Nr.	MRS Input Rates 2026 1st BiAnnual	Description	Unit	Qty	Unit Rate	Amount Rs.
1	2	3	4	5	6	7=6x5
		above not requiring form work (i.e. horizontal shuttering) complete in all respects:- (2) Type B (nominal mix 1: 1½: 3)	Cu.m	52.75		
1.6	6-12(c)	Providing and fabrication of mild steel reinforcement for cement concrete, including cutting, bending, laying in position, making joints and fastenings, including cost of binding wire and labour charges for binding of steel reinforcement (also includes removal of rust from bars), Deformed bars (Grade 60)	Kg	24,702.60		
1.7	6-32	Providing and embedding 10" (250mm) wide PVC water stopper in expansion joints of RCC structures (Retaining walls, water tanks, Slabs) complete in all respect. ii) 10 mm thick	P.Meter	53.97		
1.8	9-46	Providing & applying torch-on water proofing bitumenous membrane of specified thickness (made of Roof-Grip/ Euro Bit) duly lapped/ connected by heating with Torch over ps-6 primer i/c preparation/ smoothen the surface complete in all respect as approved and directed by the Engineer Incharge a) Plain ii) 4 mm thick	Per Sqm	315.28		
		Sub-Total				
		Total for Schedule Items				
		Total for Bill Nr.1 (Carried over to Summary of Price)				





Cooling Tower at Compressor Station CC 1 Haranpur



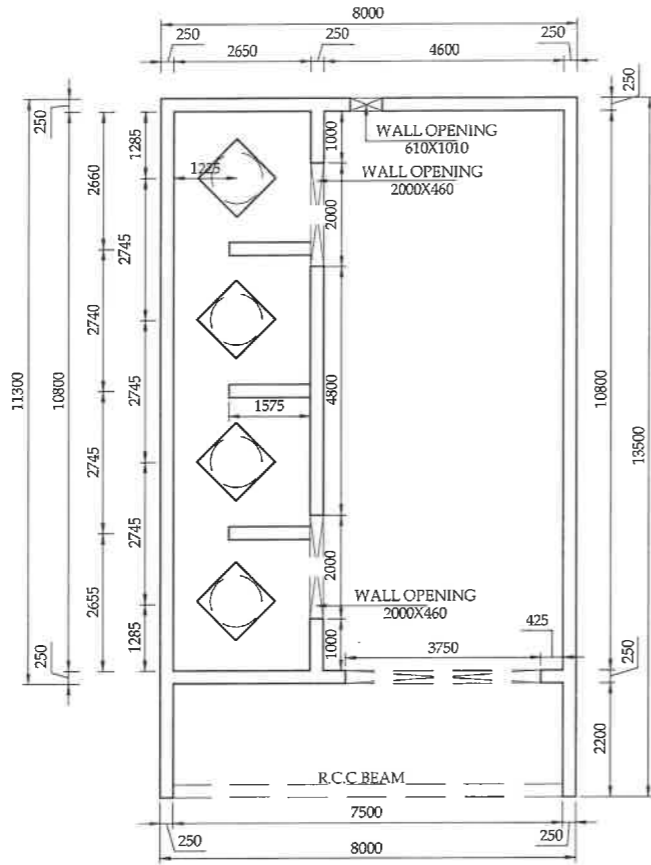

ARRANGEMENT PLAN
AT + 0.11 5M LEVEL

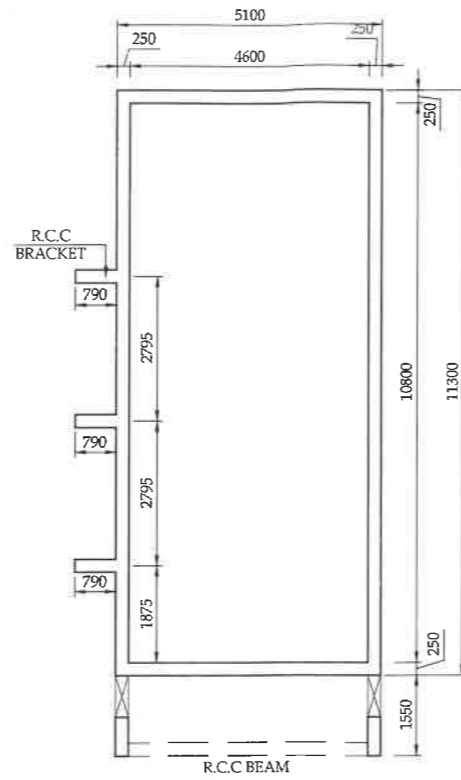

ARRANGEMENT PLAN
AT + 4.31 0M LEVEL

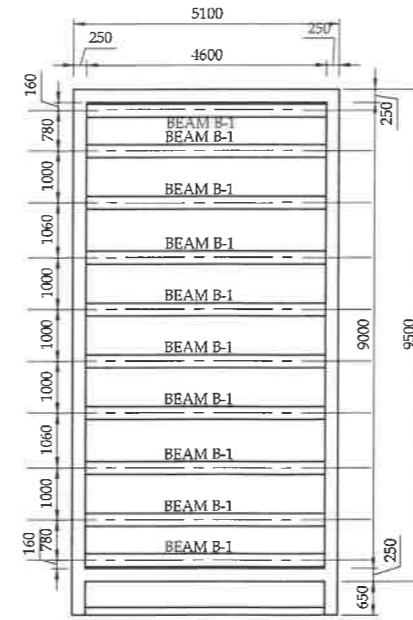

ARRANGEMENT
PLAN AT TOP LEVEL

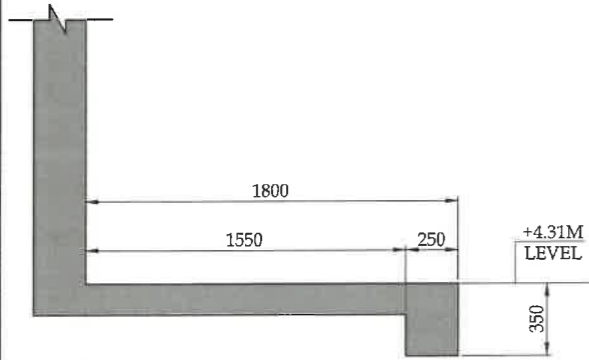

SECTION A1-A1

Scale :- 1:30

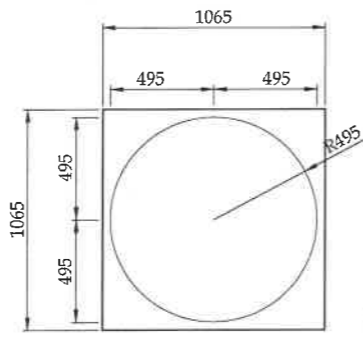

DETAIL - X

Scale :- 1:30

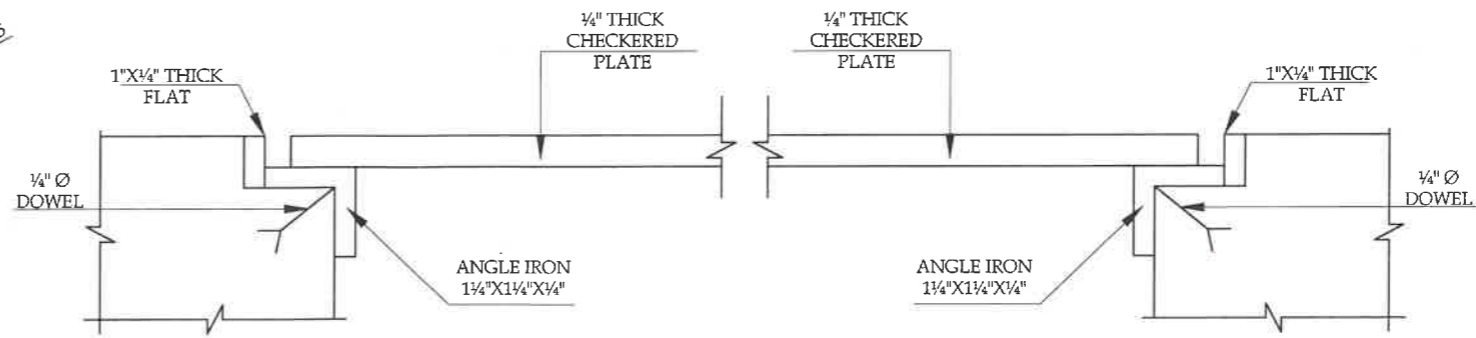

DETAIL - Y

Scale :- 1:30



SNGPL
TITLE:
ARRANGEMENT PLANS AT
-0.115M, +4.310M & TOP LEVELS

ISSUE NO.	DATE	DESCRIPTION	DRAWN	DESIGNED	APPROVED
01	10-04-2020	TENDER DRAWING	PICR	ENGR. (SNGPL)	ENGR. (SNGPL)
02					

DRAWING NO.:
S-01

SHEET NO.: 00

REV: 00

PROJECT:
COOLING TOWER AT COMPRESSOR
STATION CC1 HARANPUR



CONSULTANT:
ASIAN CONSULTING ENGINEERS (PVT) LTD.
C-3 JHILUM BLOCK, GREEN FORT-II, LAHORE, PAKISTAN
TELEPHONE: +92 42 35450914-5
FAX: +92 42 35450915 WEB: www.asiancon.com

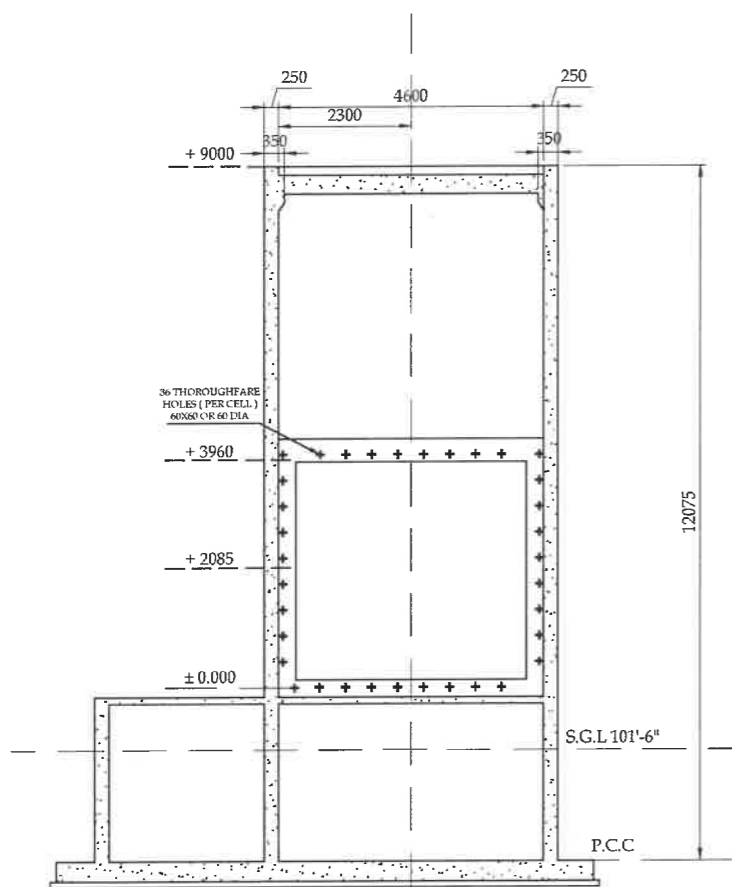

VIEW - 'A'
Scale :- 1:100

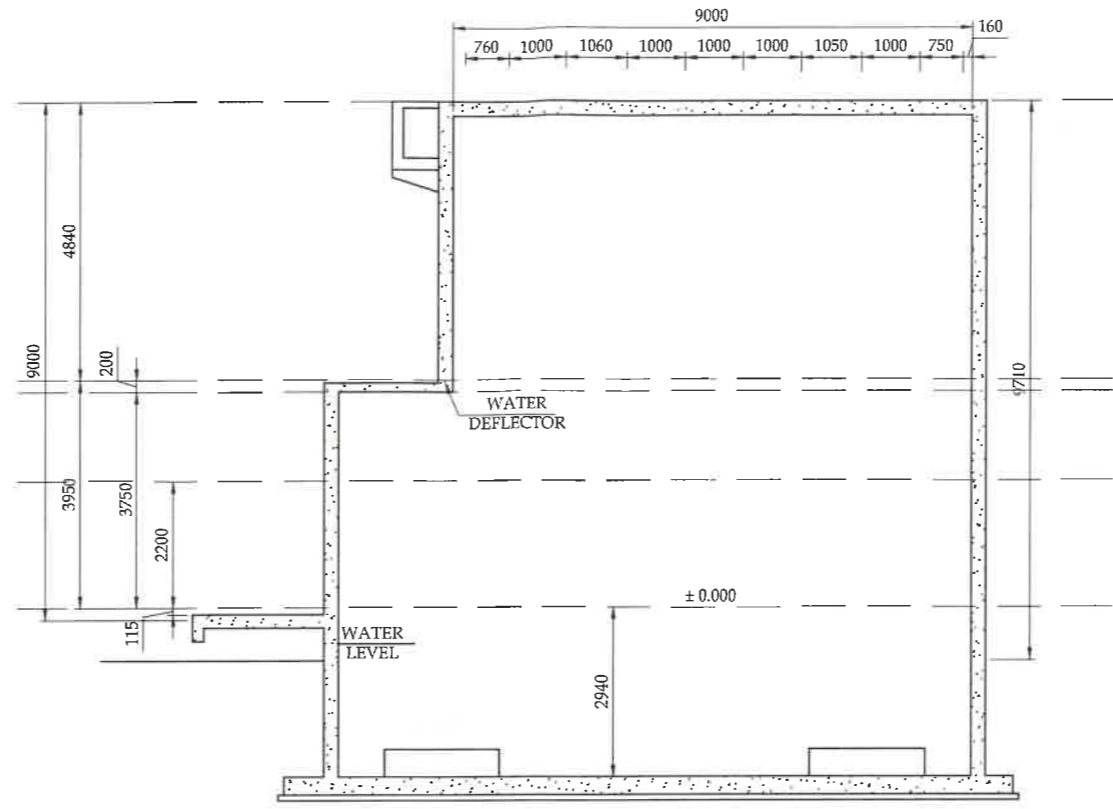

SECTION B-B
Scale :- 1:100

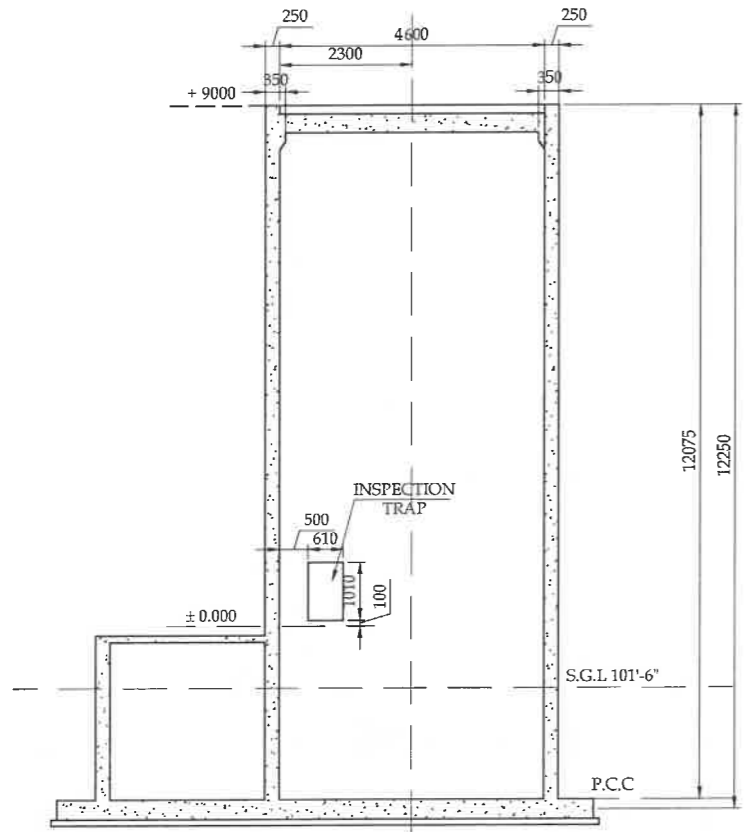

SECTION C-C
Scale :- 1:100

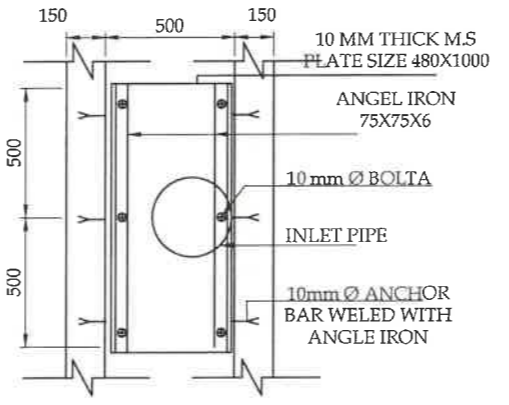

SECTION PLAN 'X'
Scale :- 1:25

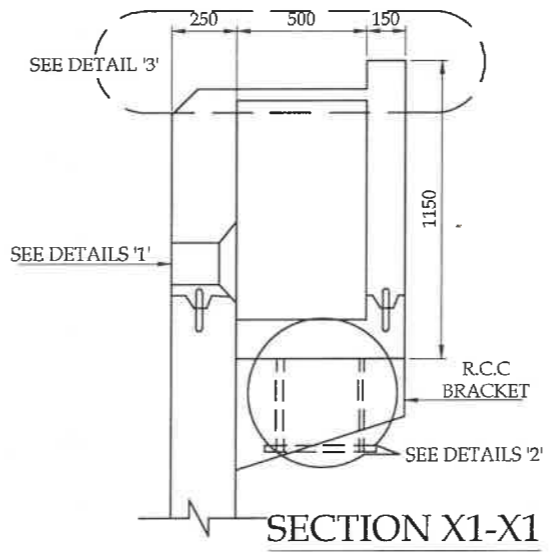

SECTION X1-X1

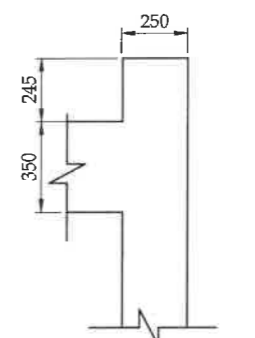

SECTION X-X

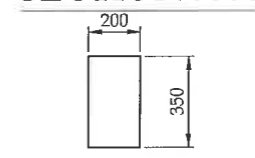

SECTION Z-Z

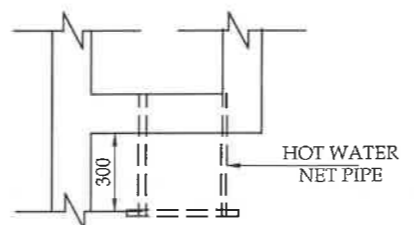

DETAIL '2'

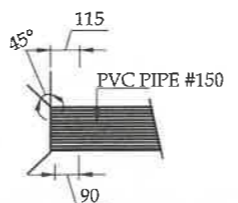

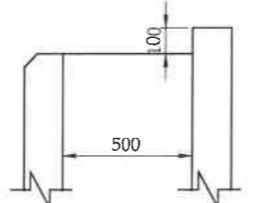

DETAIL '1'



DETAIL '3'



SNGPL		TITLE:	
ARRANGEMENT PLANS AT -0.115M, +4.310M & TOP LEVELS			
ORIGINAL:	DATE:	SCALE:	
A2	APRIL 2008		
ISSUE NO:	DATE:	DESCRIPTION:	DRAWN: DESIGNER: APPROVED:
01	10-04-2008	TENDER DRAWING	FIDA ENGR. HAJI MUHAMMAD FAHIM
02			
DRAWING NO:		SHEET:	REV:
S-02		00	00
PROJECT:			
COOLING TOWER AT COMPRESSOR STATION CC1 HARANPUR			
CLIENT:			
			
CONSULTANT:			
 ASIAN CONSULTING ENGINEERS PVT. (LTD) C-3 JHELLUM BLOCK GREEN FORT-II, LAHORE, PAKISTAN TELEPHONE: +92-42-35450914-5 FAX: +92-42-35450915 WEB: www.asiancon.com			

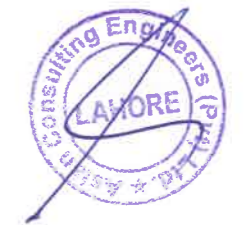
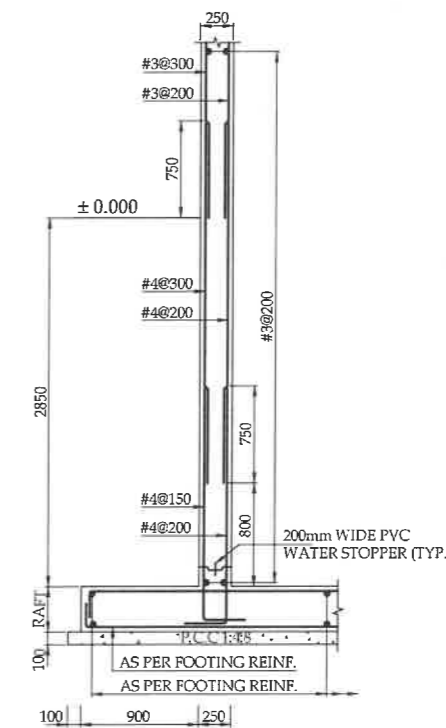
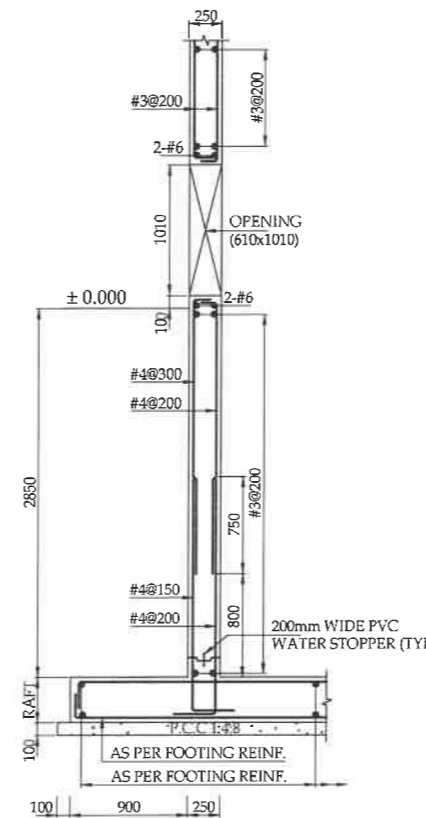
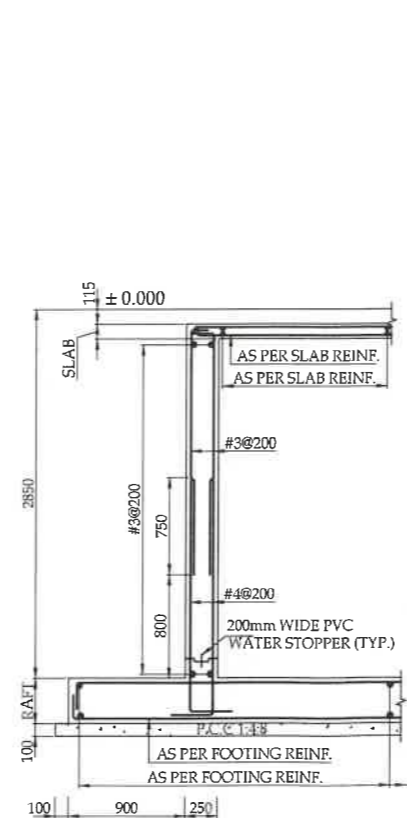
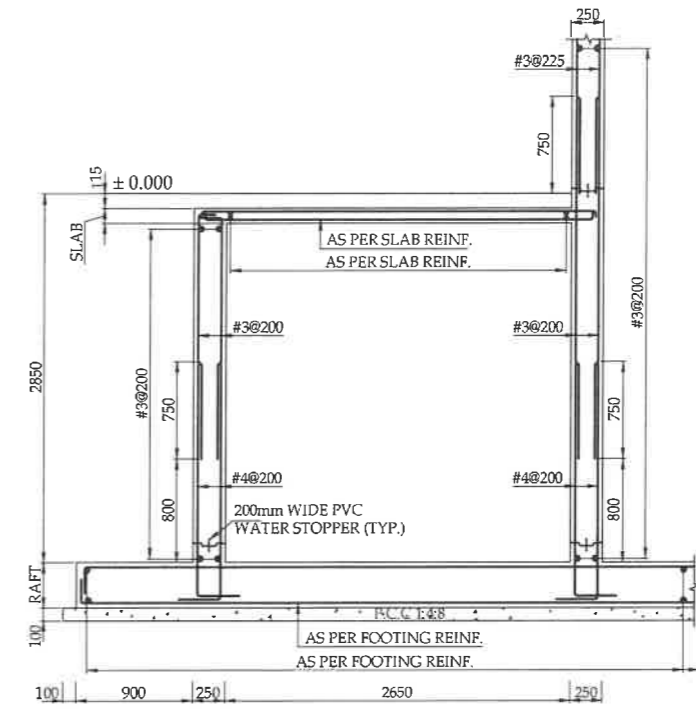
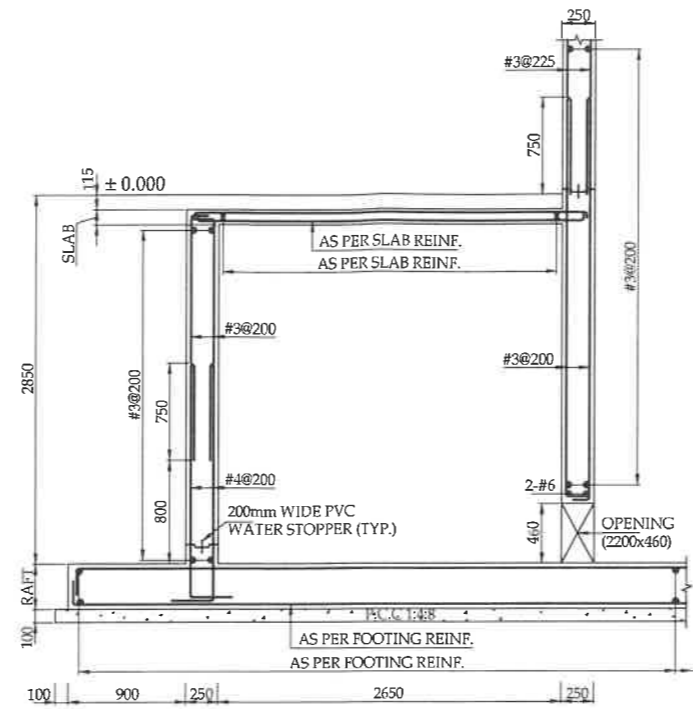
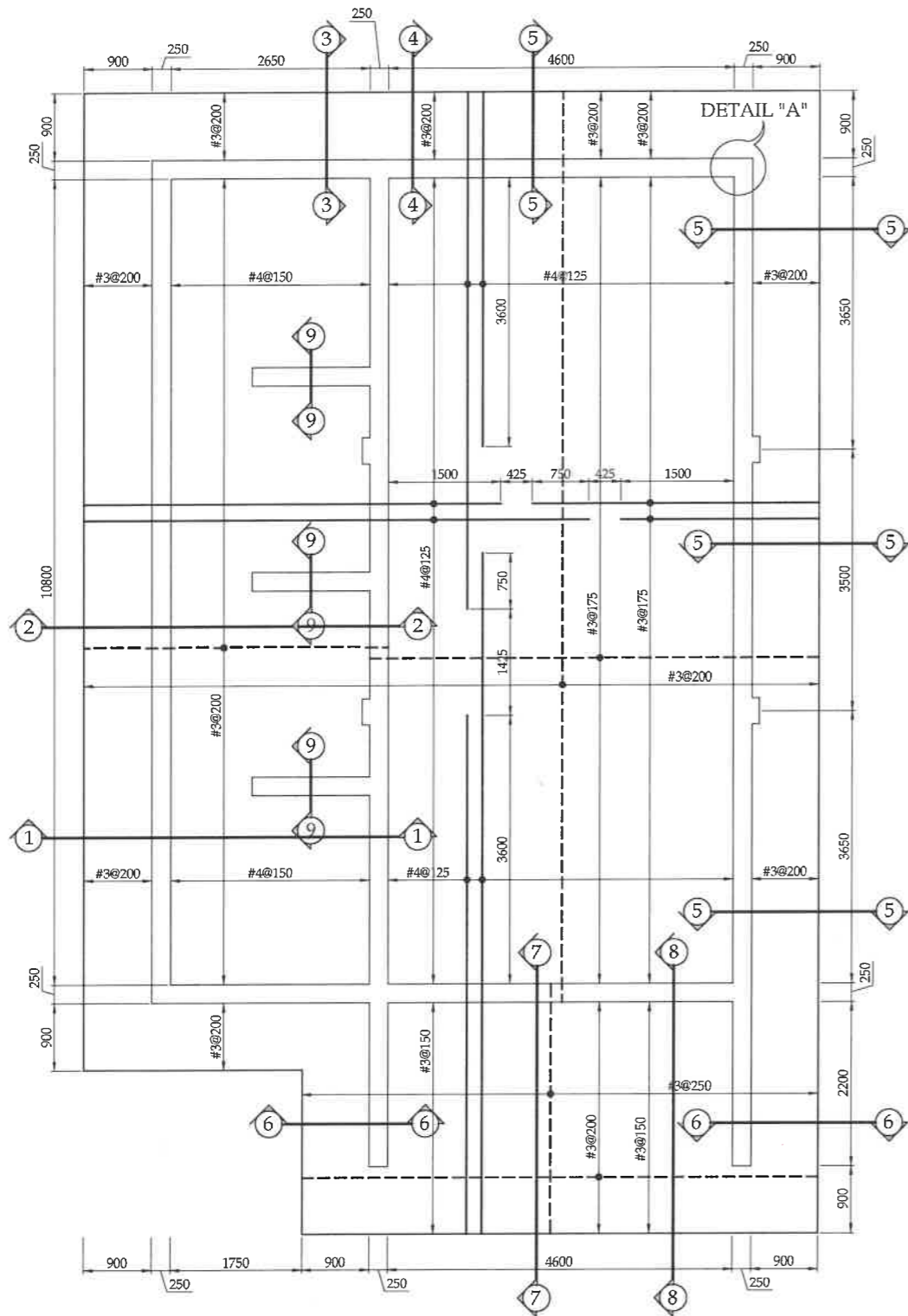

SNGPL
TITLE: FOUNDATION PLAN & SECTIONS

DATE	DESCRIPTION	DESIGN	CHECK	APPROVED
01	TENDER DRAWING	FEED	CHKD	APR 2020

DRAWING No: S-03 SHEET 00 REV 00

PROJECT: COOLING TOWER AT COMPRESSOR STATION CC1 HARANPUR



CONSULTANT: ASIAN CONSULTING ENGINEERS PVT. LTD.
C-3 JHELMUM BLDG, GREEN FORT-4, LAHORE, PAKISTAN
TELEPHONE: +92 42 35450914-5
FAX: +92 42 35450915 WEB: www.asiancon.com

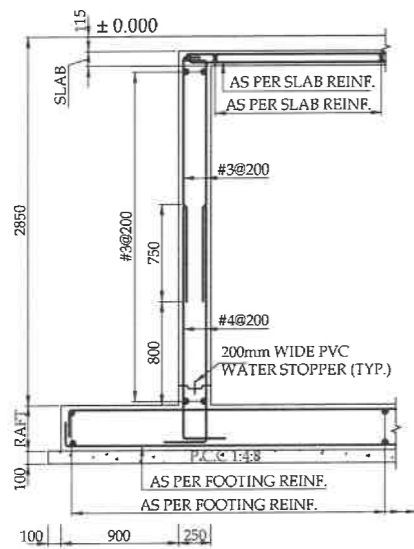

SECTION 6-6
Scale :- 1:40

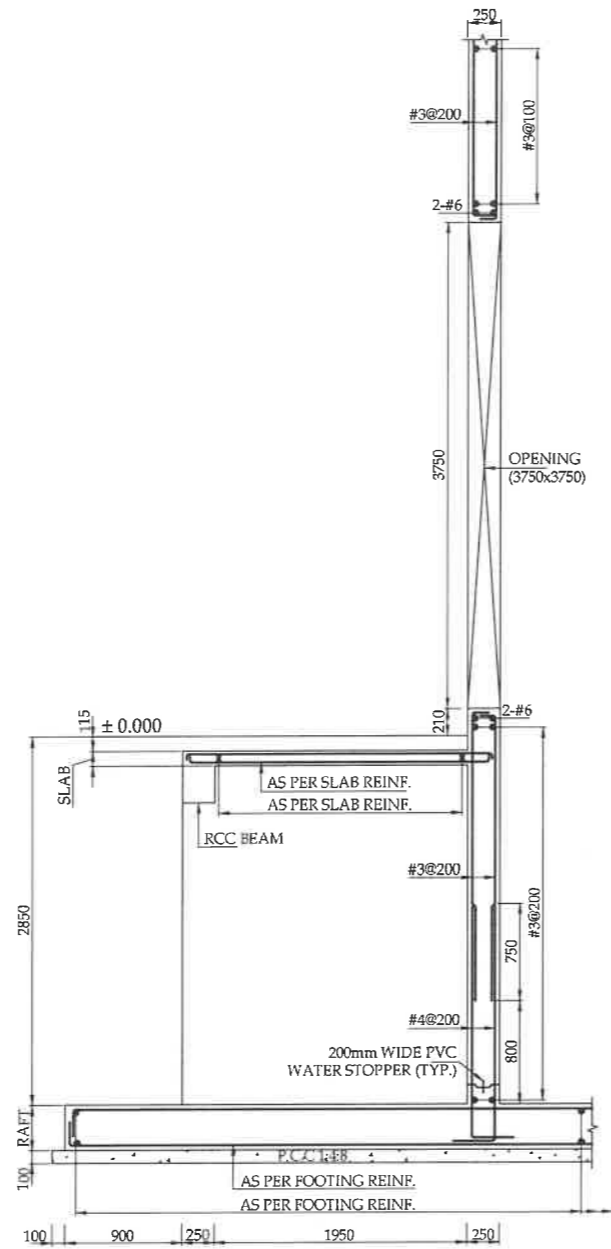

SECTION 7-7
Scale :- 1:40

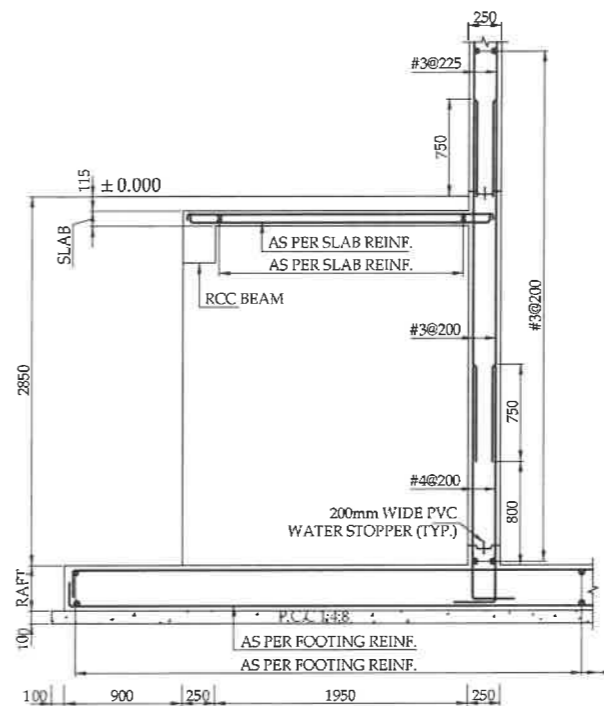

SECTION 8-8
Scale :- 1:40

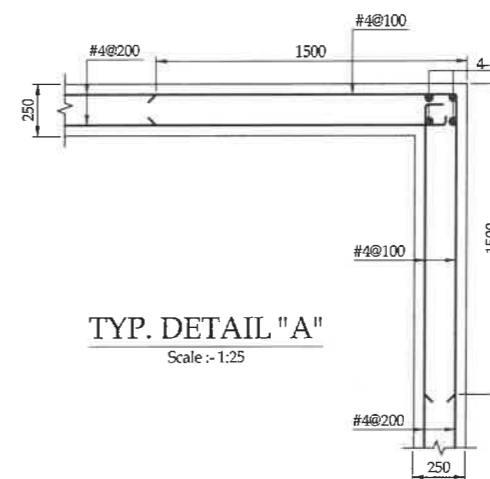

TYP. DETAIL "A"
Scale :- 1:25

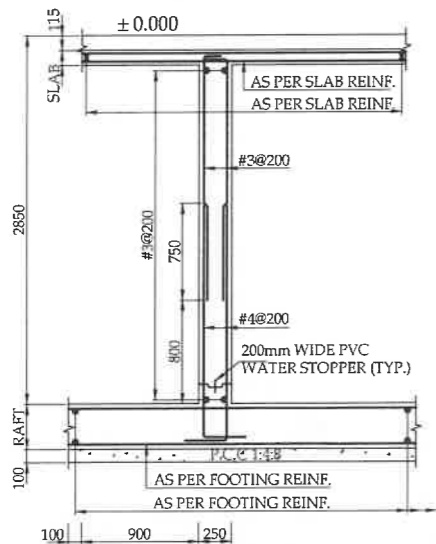

SECTION 9-9
Scale :- 1:40

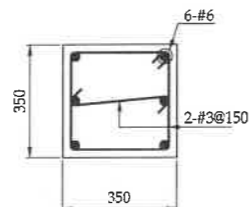

COLUMN C-1
Scale :- 1:16

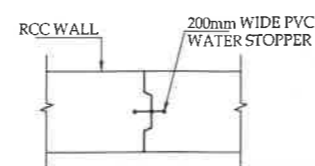

TYP. DETAIL OF VERTICAL CONSTRUCTION JOINT IN WALL
Scale :- 1:16



SNGPL
TITLE: FOUNDATION SECTIONS

ISSUE NO	DATE	DESCRIPTION	DRAWN	CHECKED	APPROVED
01	20-04-2023	TENDER DRAWING	FIDA	USMAN	FAHIM

DRAWING NO: S-04
SHEET: 00
REV: 00

PROJECT: COOLING TOWER AT COMPRESSOR STATION CC1 HARANPUR



CONSULTANT: ASIAN CONSULTING ENGINEERS (PVT) LTD.
C-3 JHELIUM BLOCK, GREEN FORT-II, LAHORE, PAKISTAN
TELEPHONE: +92 42 3560914-5
FAX: +92 42 35450916 WEB: www.asiancon.com

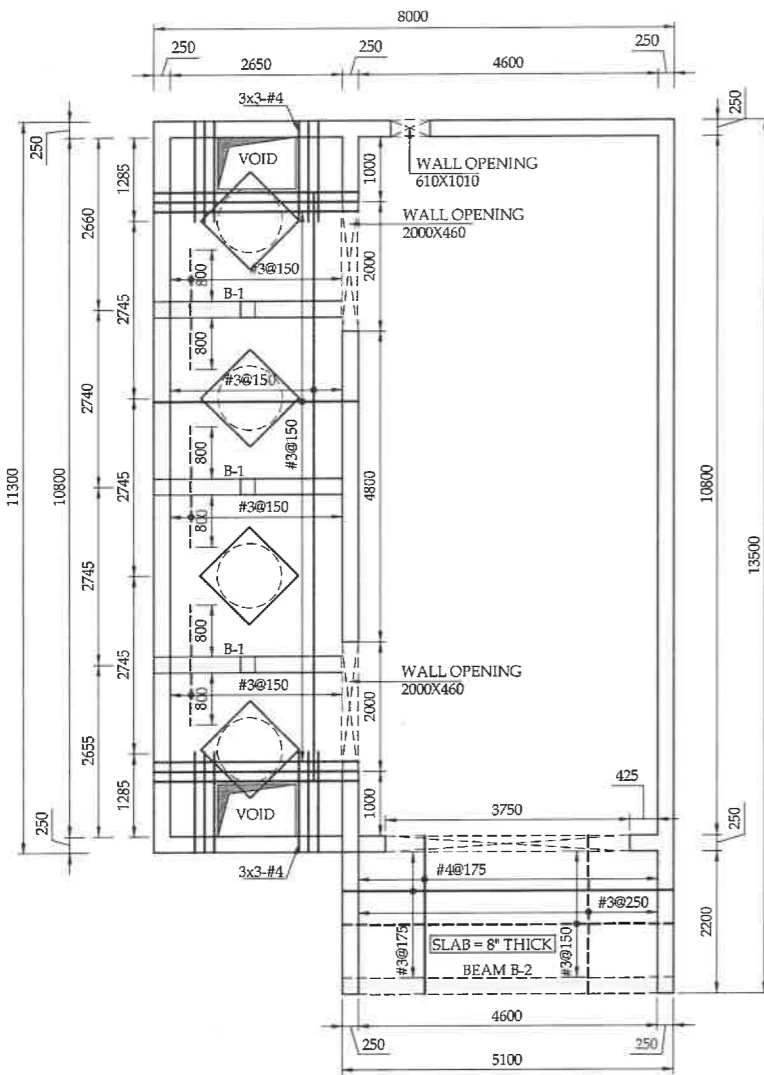

REINFORCEMENT DETAIL OF SLAB AT + 0.115M LEVEL

Scale :- 1:80
SLAB THICKNESS = 175mm UNLESS NOTED ON PLAN

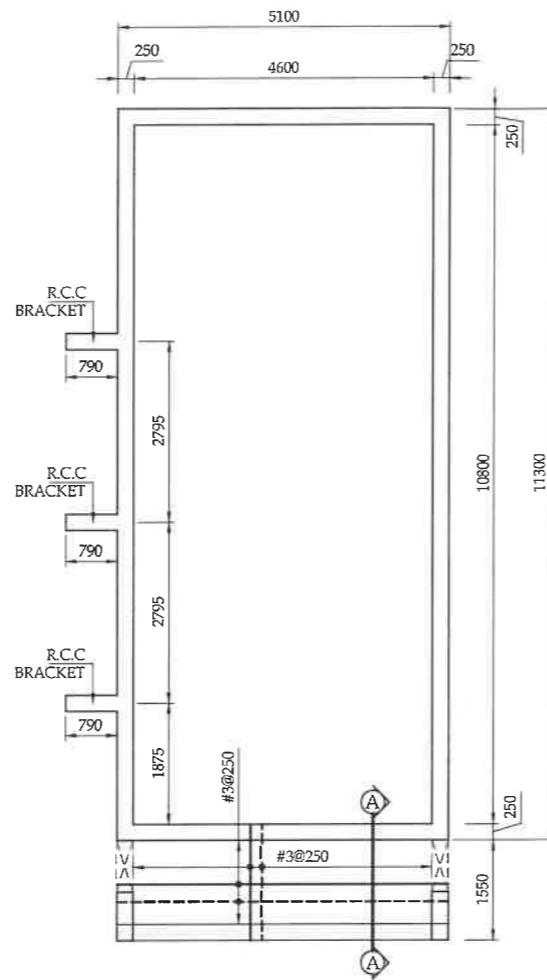

REINFORCEMENT DETAIL OF SLAB AT +4.310M LEVEL

Scale :- 1:80
SLAB THICKNESS = 175mm

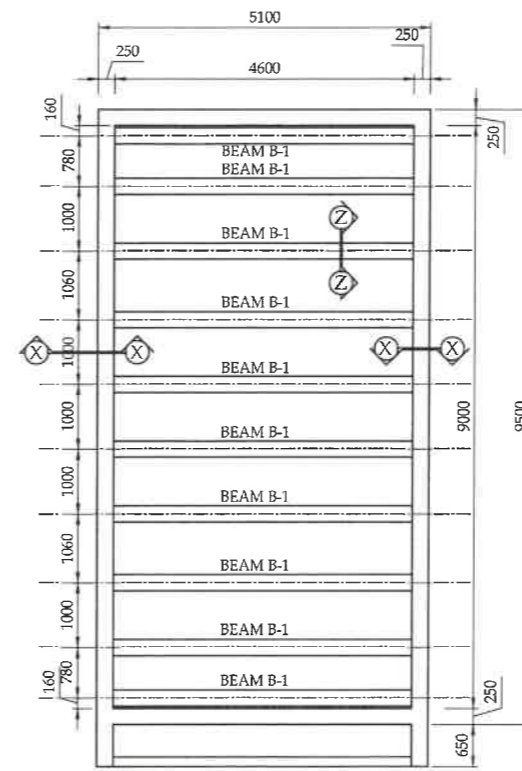

ARRANGEMENT PLAN AT TOP LEVEL

Scale :- 1:80

LEGEND :
— INDICATES BOTTOM BARS
- - - INDICATES TOP BARS

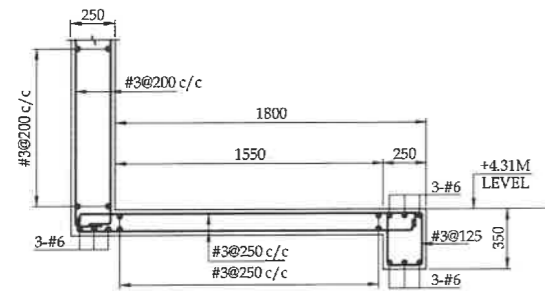

SECTION A-A

Scale :- 1:30

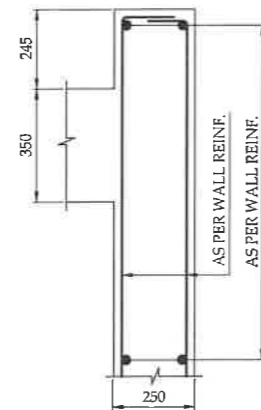

SECTION X-X

Scale :- 1:16

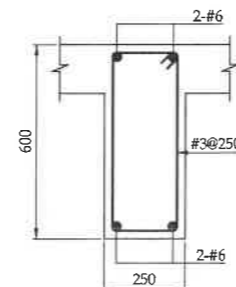

BEAM B-1

Scale :- 1:16

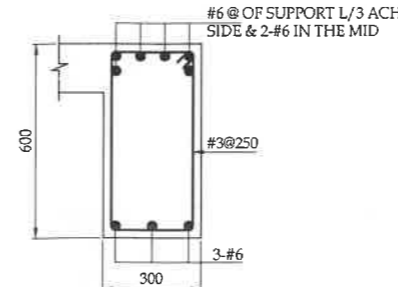

BEAM B-2

Scale :- 1:16

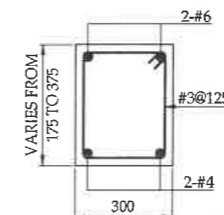

SECTION B-B

Scale :- 1:16

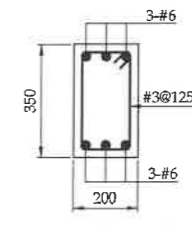

SECTION B-1 (SECTION Z-Z)

Scale :- 1:16

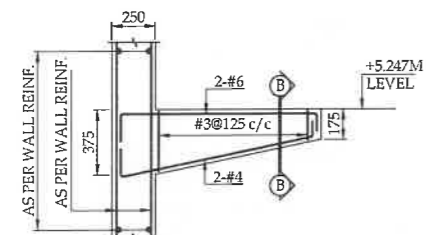

TYP. RCC BRACKET DETAIL

Scale :- 1:30

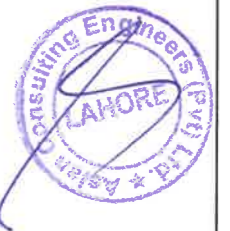

SNGPL
TITLE: DETAIL OF SLABS AT -0.115M,+4.310M
ARRANGEMENT PLAN & TOP LEVEL
SECTIONS & BEAMS

REV#	DATE	DESCRIPTION	DRAWN	CHECKED	APPROVED
01	03-04-2024	TENDER DRAWING	FIDA	ASLAN	ASLAN
02					

DRAWING NO: S-05
SHEET 00 REV 00

PROJECT:
COOLING TOWER AT COMPRESSOR
STATION CC1 HARANPUR



CONSULTANT:
ASLAN CONSULTING ENGINEERS (PVT) LTD
C-3 JHELM BLOCK, GREEN FORT-8 LAHORE, PAKISTAN
TELEPHONE: +92 42 35450914-5
FAX: +92 42 35450916 WEB: www.aslancon.com